

DrAFT: An Algorithmic Framework for Facade Design

Inês Alexandra do Côrro Caetano

Thesis to obtain the Master of Science Degree in

Architecture

Supervisor: Prof. Dr. António Paulo Teles de Menezes Correia Leitão

Examination Committee

Chairperson: Prof. Dr. Francisco Manuel Caldeira Pinto Teixeira Bastos

Supervisor: Prof. Dr. António Paulo Teles de Menezes Correia Leitão

Member of the Committee: Prof. Dr. Ana Paula Filipe Tomé

June 2015

ABSTRACT

The history of Architecture provides many examples of styles that were adopted, rejected, and then re-adopted in a similar or changed form. Before Modernism, buildings' facades were the canvas where architectural style was celebrated. However, with the birth of Modernism, and its hygienic and austere aesthetic, composing a facade was an architectural task that lost some of its prestige. After Modernism (or since Post-modernism), we witness an increasing interest in facade composition and, nowadays, designing a facade is reassuming an important role in architecture practice due, in part, to the support of digital technologies.

This dissertation discusses the development of a framework for the design of facades. Our work started with an analysis of a large corpus of contemporary facades, which were classified into different categorical dimensions that we considered computationally relevant. This classification generates a multi-dimensional space where the parts of a facade can be located. The important result of our work comes, then, from the identification and implementation of a set of fundamental algorithms and strategies that address the needs of the different dimensions of this space. Some of the locations in this multi-dimensional space can use a specific computing approach that is adequate for the creation of the designs that match the intended facade. Other locations, representing less common kinds of facades, might not have a specific computational solution, but our experience shows that is possible, using the range of tools that we developed, to quickly implement the particular solution required by that facade.

In practical terms, the end result of our research is a library of operators usable in different programming languages and a set of guidelines that helps a designer select and combine the most useful operators to implement a design for a particular facade. Some of these operators are implemented as higher-order functions, making them applicable to a wide variety of problems. Our work is implemented using Rosetta, a programming environment for generative design, allowing us to explore the generation of facades in common CAD applications, thus promoting the integration of the generative design approach in the more traditional working environment.

Keywords: Algorithm, Higher-Order Function, Generative Design, Facade

RESUMO

A história da Arquitetura proporciona vários exemplos de estilos que foram adotados, rejeitados e, mais tarde, readotados novamente de forma semelhante ou alterada. Antes do Movimento Moderno fachadas eram as telas onde os estilos arquitetônicos eram celebrados, mas a partir daí compor uma fachada tornou-se uma tarefa arquitetônica que perdera o seu prestígio. A seguir ao Modernismo (ou a partir do Pós-Modernismo) assistimos a um interesse crescente na composição da fachada e, hoje em dia desenhar uma fachada está a reassumir um papel importante na prática arquitetônica, devido principalmente ao suporte das tecnologias digitais.

Esta dissertação discute o desenvolvimento de uma infraestrutura digital para o desenho de fachadas. O nosso trabalho começou com uma análise de uma vasta gama de fachadas contemporâneas, as quais classificámos em diferentes dimensões categóricas, que considerámos ser computacionalmente relevantes. Esta classificação gera um espaço multidimensional onde as diversas partes da fachada podem ser localizadas. A relevância do nosso trabalho vem, então, da identificação e da implementação de um conjunto de algoritmos e estratégias fundamentais que resolvem as necessidades das diferentes dimensões deste espaço. Algumas das localizações neste espaço multidimensional podem usar uma abordagem computacional específica que seja adequada para a criação dos desenhos que correspondem aos da fachada desejada. Outras localizações, que representam desenhos de fachadas menos comuns, podem não ter uma solução computacional específica, mas a nossa experiência mostra que é possível, usando a variedade de ferramentas que desenvolvemos, implementar rapidamente a solução particular necessária para gerar essa fachada.

Em termos práticos, o resultado final da nossa pesquisa é uma biblioteca de operações que se pode usar em diferentes linguagens de programação e um conjunto de normas que ajudam os arquitetos a selecionar e a combinar os operadores mais úteis para a implementação do desenho de uma fachada. Alguns desses operadores são implementados como funções de ordem superior, tornando-os assim aplicáveis a uma vasta gama de problemas. O nosso trabalho é implementado usando o Rosetta, um ambiente de programação para desenho generativo, permitindo-nos assim explorar a geração de modelos de fachadas em aplicações de CAD comuns, promovendo a integração da abordagem do desenho generativo em ambientes de trabalho mais tradicionais.

Palavras-chave: Algoritmo, Funções de Ordem Superior, Desenho Generativo, Fachada

ACKNOWLEDGMENT

A special acknowledgment to Professor António Leitão, the supervisor of this thesis, for introducing me such an interesting topic, for everything he taught me during the course of this work, for his supportive and ever-present guidance, for the availability that he ever had for any clarification or doubt, and also for his dedication, patience and enthusiasm that helped me a lot until the conclusion of this thesis.

To my parents for their understanding and support during the development of this work.

To the members of GAC for the relevant comments and advices.

To my friends for their understanding and patience.

This work was partially supported by national funds through Fundação para a Ciência e a Tecnologia (FCT) with reference UID/CEC/50021/2013, and by the Rosetta project under contract PTDC/ATP-AQI/5224/2012.

AGRADECIMENTOS

Um especial agradecimento ao Professor António Leitão, o orientador desta tese, por me introduzir um tópico tão interessante como este, por tudo o que me ensinou no decorrer deste trabalho, pelo suporte e supervisão sempre presentes, pela disponibilidade total que sempre teve para qualquer esclarecimento ou dúvida, e ainda pela sua dedicação, paciência e entusiasmo que me ajudaram bastante até à conclusão desta tese.

Aos meus pais pelo seu suporte e compreensão durante o desenvolvimento deste trabalho.

Aos membros do GAC pelos comentários e conselhos relevantes.

Aos meus amigos pela sua compreensão e paciência.

Este trabalho foi suportado parcialmente por fundos nacionais através da Fundação para a Ciência e a Tecnologia (FCT) com referencia UID/CEC/50021/2013, e pelo projeto Rosetta sob o contrato PTDC/ATP-AQI/5224/2012.

CONTENTS

ABSTRACT	iii
RESUMO	v
CONTENTS	ix
LIST OF FIGURES	xiii
LIST OF TABLES	xxv
ABBREVIATIONS	xxvii
GLOSSARY OF TERMS	xxvii
INTRODUCTION	xxix
OBJECTIVES	xxxiii
METHODOLOGY	xxxiii
STRUCTURE	xxxiv
PART I. BACKGROUND	1
1 ORNAMENT	3
1.1 ORNAMENT, DECORATION AND PATTERNS	3
1.2 ORNAMENT IN ARCHITECTURE	4
2 THE CONTEMPORARY FACADE: NEW EXPRESSIONS IN ARCHITECTURE	11
2.1 FACADE: THE OUTER LAYER OF ARCHITECTURE	12
2.2 NEW ARCHITECTURAL EXPRESSIONS	14
2.2.1 NEW GEOMETRIES	16
2.2.2 PERFORMATIVE ARCHITECTURE	18
2.2.2.1 Performative Architecture as Performance-Based Design	19
2.2.2.2 Performative Design as an Architecture of Performance	21
2.2.2.3 Architecture as Both Performance and Performance-Based Design	22

2.2.3	KINETIC OR ADAPTIVE ARCHITECTURE	24
2.2.3.1	INSTITUT DU MONDE ARABE	25
2.2.3.2	NEW ESKENAZI HOSPITAL PARKING STRUCTURE.....	26
2.2.4	PARAMETRIC ARCHITECTURE.....	27
3	NEW TECHNOLOGIES	29
3.1	GENERATIVE DESIGN.....	30
3.2	GENERATIVE SYSTEMS.....	32
3.3	PARAMETRIC SYSTEMS	35
3.3.1	HISTORY OF PARAMETRIC TOOLS.....	36
3.3.2	PARAMETRIC TOOLS: FINDING A MEANING.....	37
4	GENERATIVE DESIGN: ARCHITECTURAL PRACTICE.....	41
4.1	GENERATIVE DESIGN STRATEGIES.....	41
4.2	CASE STUDY 1: AVIVA STADIUM.....	44
4.3	CASE STUDY 2: BEIJING NATIONAL AQUATIC CENTER	47
	PART II. A FRAMEWORK FOR THE GENERATION OF CONTEMPORARY FACADES	51
5	INTRODUCTION	53
6	ALGORITHMIC FACADES	55
6.1	CLASSIFICATION STRATEGY	56
6.2	DESIGN STAGES & CATEGORICAL DIMENSIONS.....	58
6.2.1	FACADE'S GEOMETRY	60
6.2.2	ELEMENT'S GEOMETRY	63
6.2.3	ELEMENT'S DEFORMATION	64
6.2.4	ELEMENT'S SIZE.....	66
6.2.5	ELEMENT'S DISTRIBUTION	68

6.2.6	ELEMENT'S ROTATION.....	72
6.2.7	FACADE'S ARTICULATION	74
6.2.8	FACADE'S MATERIAL AND COLOR	77
6.3	CLASSIFICATION SYNTHESIS.....	79
7	THE APPLICATION OF THE FACADE'S CLASSIFICATION.....	81
7.1	CLASSIFICATION OF FACADES	82
EXAMPLE 1	CAMPUS NETZWERK OFFICE, GERMANY	82
EXAMPLE 2	MEDIOPADANA STATION, ITALY	83
EXAMPLE 3	GANTENBEIN VINEYARD, SWITZERLAND	84
EXAMPLE 4	CASCAIS HOUSE, PORTUGAL.....	86
EXAMPLE 5	QUALITY HOTEL FRIENDS, SWEDEN.....	87
EXAMPLE 6	SUZHOU SND DISTRICT URBAN PLANNING EXHIBITION HALL, CHINA.....	88
EXAMPLE 7	UTRECHT UNIVERSITY LIBRARY, NETHERLANDS	89
EXAMPLE 8	LOUIS VUITTON STORE, JAPAN.....	90
7.1.2	ANALYSIS OF THE PRACTICAL EXAMPLES	91
8	FACADES GENERATION PROCESS	93
8.1	ANALYSIS OF THE FACADE'S DESIGN	93
8.2	FACADE'S CLASSIFICATION	96
8.3	IMPLEMENTATION OF THE ALGORITHMS	97
8.4	MODEL EXPLORATION	99
9	THE GENERATION OF CONTEMPORARY FACADES	105
9.1	PRACTICAL APPLICATION.....	105
9.2	THE APPLICATION ON REAL FACADES	115
9.2.1	QUALITY HOTEL FRIENDS, SWEDEN	115

9.2.2	CAMPUS NETZWERK, GERMANY.....	121
9.2.3	HOUSE AAG, SPAIN	127
9.2.4	GANTENBEIN VINEYARD, SWITZERLAND	133
9.2.5	FACIM WATERFRONT IN MAPUTO, MOZAMBIQUE.....	140
10	OTHER APPLICATIONS	147
11	EVALUATION	153
11.1	EVALUATING THE FRAMEWORK'S FLEXIBILITY	154
11.2	TRADITIONAL VS. ALGORITHMIC APPROACH	158
11.2.1	THE MODELS GENERATION TIME	158
11.2.2	THE VARIATION OF THE MODELS	160
11.3	THE PORTABILITY OF THE FRAMEWORK	163
11.4	OTHER EXISTING TOOLS.....	165
12	CONCLUSION AND FUTURE WORK.....	167
12.1	CONCLUSION.....	167
12.2	FUTURE WORK.....	169
12.3.	CONTRIBUTIONS.....	170
	BIBLIOGRAPHY	173

LIST OF FIGURES

Fig.1 - The FACIM WaterFront Project by Bak Gordon, in Maputo, Mozambique (source: http://www.bakgordon.com/).....	xxxii
Fig.2 – An image of the towers' interior with the patterned skin visible. (source: Bak Gordon's Studio).....	xxxii
Fig.3 - The skin pattern based on African motifs (source: Bak Gordon's Studio).....	xxxii
Fig.1.1 - Manueline Ornamentation in the cloisters of Jerónimos Monastery in Belém, Portugal (source: https://www.pinterest.com/).....	3
Fig.1.2 - Patterns in Architecture: Portuguese Tiles (source: https://www.pinterest.com/pin/).....	3
Fig.1.3 - Baroque: the Queen's room in the Versailles Palace in France. The ornamentation exuberance is very characteristic of this style (source: http://en.wikipedia.org/wiki/Palace_of_Versailles/).....	4
Fig.1.4 – Roman Empire: Statues were used to ornament temples. (source: http://www.2020site.org/).....	4
Fig.1.5 – Rossio Station's in Lisbon: the doors are ornamented so as to recreate the Portuguese Manueline style (source: https://www.flickr.com/).....	4
Fig.1.6 - Parametric patterns and facades: Erwin Hauer- continua architectural screens and walls (http://www.erwinhauer.com/)..	8
Fig.1.7 - Contemporary Ornament: John Lewis department store in Leicester, UK, by Foreign Office Architects (source: http://designresearch.sva.edu/research/patterns-of-ornament-technology-and-theory-in-contemporary-architectural-decoration-2/).....	9
Fig.2.1 - Photography of the Guggenheim Museum by Frank Gehry in Bilbao, Spain (source: http://www.guggenheim-bilbao.es/en/the-building/outside-the-museum/).....	12
Fig.2.2 - Photography of the Beijing National Stadium (source: www. http://21stcenturyarchitecture.blogspot.pt).....	13
Fig.2.3 - A digital image of the Beijing National Stadium project by Herzog & De Meuron (source: www.openbuildings.com)....	13
Fig.2.4 – The patterned skin of the Federation Square buildings in Melbourne, Australia (2002), by LAB Architecture Studio (source: http://www.architravel.com/).....	13
Fig.2.5 – The Serpentine Pavillion in London (2002) by Cecil Belmond and Toyo Ito (source: http://www.archdaily.com/)	13
Fig.2.6 – Image of the Eiffel Tower in Paris by Gustave Eiffel (source: www.smithsonianmag.com).....	15
Fig.2.7 - Image of the Crystal Palace built by Joseph Paxton (source: www.telegraph.co.uk)	15
Fig.2.8 - Vodafone building in Oporto (Portugal) designed by Barbosa e Guimarães Architects (source: http://21stcenturyarchitecture.blogspot.pt).....	15
Fig.2.9 – Troia Design Hotel in Troia, Portugal, by Promontório Arquitectos (source: http://www.troiadesignhotel.com/)	15

Fig.2.10 - Image of the Archigram's Plug-in City (1964): This provocative project suggests a hypothetical fantasy city, containing modular residential units that "plug in" to a central infrastructural mega machine. The Plug-in City is in fact not a city, but a constantly evolving megastructure that incorporates residences, transportation and other essential services—all movable by giant cranes (source: http://www.archdaily.com).....	16
Fig.2.11 – ICD/TKE Research Pavilion (2011) Stuttgart University by Achim Menges and J. Knippers (source: http://www.achimengenes.net/).....	17
Fig.2.12 – 3D Spacer Textile Composites by Nico Reinhardt (source: http://www.achimengenes.net/)	17
Fig.2.13 - Image of a NURBS surface with its controllable vertices in red (source: www.3dmax-tutorials.com).....	17
Fig.2.14 - Photography of BMW Welt in Munich by Coop Himmelb(l)au (source: http://www.archithings.com)	17
Fig.2.15 – Different screens designed with algorithmic tools, which helped the manipulation of the contours, dimensions, angles and the sequence of openings. The screens were produced with robotic cutting. Designed and produced by Gramazio & Kohler Research (source: http://gramaziokohler.arch.ethz.ch/).....	18
Fig.2.16 - Photography of the City Hall in London, designed by Foster+Partners (source: http://www.fosterandpartners.com)...	20
Fig.2.17 - Photography of the Kunsthaus dynamic display surface of lights, in Graz, Austria (source: www.aracnob.blogspot.pt)	21
Fig.2.18 – An exploded view of the lights matrix as a part of the Kunsthaus facade (source: (Edler, 2005)).....	22
Fig.2.19 - Photography of Southern Cross Station in Melbourne, Australia (source: http://openbuildings.com)	23
Fig.2.20 – An example of Kinetic architecture of the past: Drawbridge at the fort of Ponta da Bandeira in Lagos, Portugal (source: http://en.wikipedia.org/wiki/Drawbridge).....	24
Fig.2.21 - The kinetic Mashrabiya (source: http://www.archdaily.com/).....	25
Fig.2.22 – The diaphragms of the Mashrabiya units (source: www.archdaily.com).....	25
Fig.2.23 - Photography of the Institut du Monde Arabe in Paris, France (1981–1987) (source: http://www.archdaily.com/)	25
Fig.2.24 - Photography of the New Eskenazi Hospital Parking Structure by Urbana Architects (source: www.arch2o.com)	26
Fig.2.25 - Some of the different effects produced by the facade depending on the viewers place of view (source: www.arch2o.com).....	27
Fig.2.26 - Rendered view of the Engineering Research Institute at the Minho University (Guimarães) by Cláudio Vilarinho Architects (source: www.claudiovilarinho.com). The building's skin was inspired by the microscopic image of titanium nanotubes.	27
Fig.2.27 - Photography of Airspace Tokyo by Faulders Studio (source: www.arch20.com). The building's skin manifests organicity, thereby resembling a neurological system.....	28
Fig.2.28 - Image of a Parametric Form Finding technique (source: http://designontopic.files.wordpress.com).....	28

Fig.2.29 – The “Bubble” BMW pavilion in Frankfurt, Germany. Its form inspiration was based on two drops of water joined together. The pavilion was designed by Bernhard Franken (source: http://www.itaproject.eu/).....	28
Fig.3.1 - Synthetic Scheme of Generative Design.....	30
Fig.3.2 - An example of the process of Genetic Algorithms (source: (Chouchoulas & Day, 2007)).....	33
Fig.3.3 - An example of a shape grammar (source: www.andrew.li).....	33
Fig.3.4 - Serpinski Lsystem (source: Wikipedia).....	34
Fig.3.5 - Cellular automata from the Game of Life, 1970 (source: www.joshiscorner.com).....	34
Fig.3.6 - An example of a parametric surface.....	35
Fig.3.7 - Frei Otto's form finding technique, foam bubbles (source: http://www.plataformadeartecontemporaneo.com/)	36
Fig.3.8 - Ivan Sutherland's Sketchpad console (1962). Sketchpad is operated with a light pen and a command button box (under left hand). The four black knobs below the screen control position and scale of the picture (source: www.mprove.de).....	36
Fig.3.9 - Pro/Engineer in 1988 (source: www.deskeng.com).....	37
Fig.3.10 – AutoCAD 2000 environment (source: http://www.eurocitysoftware.com/).....	37
Fig.3.11 – Rhino5 environment (source: http://3.bp.blogspot.com/).....	37
Fig.3.12 - Parametric Variations: The number of stripes in each model varies between 6 and 11 stripes.....	38
Fig.4.1 - A photography of the interior of Sagrada Familia in Barcelona (source: http://archinect.com/).....	41
Fig.4.2 - Smithsonian Institution by Foster+Partners in Washington DC, USA (2007) (source: www.fosterandpartners.com/).....	42
Fig.4.3 - City Hall or Greater London Authority by Foster+Partners (source: www.fosterandpartners.com).....	42
Fig.4.4 - Serpentine Gallery Pavilion (2005) by Alvaro Siza and Eduardo Souto Moura with Cecil Balmond – Arup (source: http://www.telegraph.co.uk/).....	43
Fig.4.5 - The Barcelona Fish by Frank Gehry and Partners (source: www.buildingsatire.com).....	43
Fig.4.6 - Computer and built models for Gehry's fish sculpture 1992 Barcelona (source: https://mafana.wordpress.com).....	43
Fig.4.7 – Aviva Stadium in Dublin by Populous architecture (source: www.archilovers.com)	44
Fig.4.8 – Parametric definition of the stadium's geometry: <i>a</i> - radial grid of the structure of the roof bays; <i>b</i> - definition of the footprint of the stadium; <i>c</i> - definition of the inner edge of the roof; <i>d</i> - definition of the origin of each sectional curve; <i>e</i> - definition of the section curve; <i>f</i> - definition of the vertical coordinates for each section curve; <i>g,h</i> - construction of each sectional curve and then the lofting of a surface through those curves; <i>i</i> - subdivision of the radial roof bay grid into mullion grid lines (source: (Shepherd, et al., 2011)).....	45
Fig.4.9 – Structural elements output from parametric model (source: (Shepherd, et al., 2011)).....	46

Fig.4.10 – A photography of Beijing National Aquatic Center (source: http://www.archello.com/).....	47
Fig.4.11 – Weaire and Phelan’s proposal for portioning 3D space. The image on the left represents a cluster of repetitive units and, the image on the right represents the repetitive module (source: (Eastman, et al., 2008)).....	47
Fig.4.12 - CAD model of the structural system of the Water Cube Project (source: http://architectureau.com/).....	48
Fig.4.13 – Building’s structure prototyping (source: http://www.e-architect.co.uk/).....	48
Fig.4.14 – Interior view of the Water Cube pavilion showing the almost complete structure (source: (Eastman, et al., 2008))..	49
Fig.4.15 – Interior of the Water Cube pavilion (source: http://www.arup.com/Projects/).....	49
Fig.6.1 - Continua Screen, design 1 - pattern developed by Erwin Hauer in the 1950’s (source: (Hauer, 2004))	54
Fig.6.2 – P-wall (2006) developed in Banvard Gallery, Knowlton School of Architecture, Ohio State University, USA (source: http://matsysdesign.com/).....	54
Fig.6.3 – Sawdust Screen in Walnut material, by Emerging Objects (source: http://www.emergingobjects.com/)	54
Fig.6.4 - Selfridges Building in Birmingham, UK (source: http://www.contemporist.com/).....	55
Fig.6.5 - Monteagudo Museum in Murcia, Spain (source: http://www.archdaily.com/).....	55
Fig.6.6 - French Pavilion in Expo Shanghai 2010 (source: http://www.tridonic.com/).....	55
Fig.6.7 - Louis Vuitton Flagship Store in Fifth Avenue in New York, USA (source: http://www.archdaily.com/).....	56
Fig.6.8 – Image synthesis of the classification’s categorical dimensions. The eight dimensions are organized in four different sets, which correspond to the design stages: 1- definition of the facade’s geometry; 2- definition of the facade’s elements; 3- distribution of the elements; 4- facade’s final appearance.....	59
Fig.6.9 - Facade Geometry: Straight Facade - Formestelle Office Building in Töging am Inn, Germany (source: www.dezeen.com/)	60
Fig.6.10 - Facade Geometry: Cylindrical Facade - Suzhou SND District Urban Planning Exhibition Hall in Jiangsu, China (source: http://www.archdaily.com/).....	60
Fig.6.11 - Facade Geometry: Facade with horizontal waving - Apartment house in Tokyo (source: https://www.japlustu.com/)....	61
Fig.6.12 - Facade Geometry: Facade with vertical waving - GT Tower East, in Seoul (source: http://www.contemporist.com/).....	61
Fig.6.13 - Facade Geometry: Sinusoidal and co-sinusoidal Facade - Boiler House at Guy’s Hospital in London, UK (source: http://www.dezeen.com/).....	61
Fig.6.14 – Facade’s Geometry: Facade with vertical and horizontal waving - Mediopadana Station in Bologna, Italy (source: www.ediliziaeterritorio.ilsolo24ore.com/).....	62
Fig.6.15 - Selfridges Building in Birmingham, UK (source: http://www.contemporist.com/)	62

Fig.6.16 – Scheme of the process behind the Facade’s Geometry dimension: an initial surface is then submitted to a sampling process, from which results a mesh of points. Then, it is organized in a quadrangular matrix, defined by sets of four points.....	62
Fig.6.17 - Element's Geometry: Circular Elements - New Center for Manufacturing Innovation in Monterrey, Mexico. (source: http://www.archilovers.com/).....	63
Fig.6.18 - Element's Geometry: Hexagonal Elements - The Cube in Milan, Italy (source: http://www.e-architect.co.uk/).....	63
Fig.6.19 - Element's Geometry: Spherical elements - Hanjie Wanda Square in China (source: http://www.archdaily.com/)	63
Fig.6.20 - Element's Geometry: Stripes Elements - Aspen Art Museum in Aspen, USA (source: http://www.archilovers.com/).....	64
Fig.6.21 - Element's Geometry: Pictorial Elements - Mayfair House in London, United Kingdom (source: www.archilovers.com)	64
Fig.6.22 - Element's Deformation: Twisted Elements - Huaxin Business Center in Xuhui, China (source: http://openbuildings.com)	65
Fig.6.23 - Element's Deformation: Undulated Elements - Visitor Pavilion National Museum Palace in Het Loo, Apeldoorn, Netherlands (source: http://www.archilovers.com/).....	65
Fig.6.24 - Element's Deformation: Interlaced Elements - Argul Weave Building in Bursa, Turkey (source: www.archdaily.com).....	65
Fig.6.25 - Element's Deformation: Bended Elements - Pan American Health Organization Building, Washington DC , USA (source: http://flickrhivemind.net/Tags/dc,paho)	66
Fig.6.26 - Element's Size: Increasing Elements - The Tourist Office and Landscaping of Quinta do Aido, Portugal (source: http://www.archdaily.com/).....	66
Fig.6.27 - Element's Size: Attracted Elements - Quality Hotel Friends in Sweden (source: www.archilovers.com).....	66
Fig.6.28 - Element's Size: Random Elements - Cascais House, Portugal (source: www.guedescruzarquitecto.wix.com/).....	67
Fig.6.29 - Element's Size: Pictorial Elements - Hästsportens Hus in Sweden (source: http://notedesignstudio.se/).....	67
Fig.6.30 - Element's Distribution: In Rows - commercial block in Tokyo by Japanese firm Amano Design Office, Japan (source: http://www.dezeen.com/).....	68
Fig.6.31 – Synthesis of the type of 1D distributions available within our framework.....	68
Fig.6.32 – The grid of points controls the size of the elements in order to fit the metrics.....	69
Fig.6.33 – Creation of an element between the four points (left-side) and the mapping of the element on the grid of points with random rotations (right-side).....	70
Fig.6.34 - Element's Distribution: in Chess-Grid - Knowledge Center at St. Olav's Hospital, Norway (source: www.archdaily.com/)	70
Fig.6.35 - Element's Distribution: Recursive Grid - The Cube in Birmingham, UK (source: http://www.wiconaco.uk/).....	70
Fig.6.36 – The type of distributions in 2D available in the Framework.....	71

Fig.6.37 - Element's Distribution: Pictorial Grid - Podcetrtek Sports Hall in Slovenia (source: http://www.archdaily.com/).....	72
Fig.6.38 - Element's Distribution: 3D distribution - MegaFaces Pavilion Sochi 2014 Winter Olympics in Russia (source: https://www.pinterest.com/).....	72
Fig.6.39 - Element's Rotation: Horizontal Rotation - Huaxin Business Center in China (source: http://www.archdaily.com/).....	72
Fig.6.40 - Element's Rotation: Pictorial Rotation - Winery Gantenbein by Gramazio & Kohler in Switzerland (source: http://www.gramaziokohler.com/).....	73
Fig.6.41 - Facade's Articulation: Perforated Facade - House 77 by Diniso Lab in Póvoa do Varzim, Portugal (source: http://www.dezeen.com/).....	74
Fig.6.42 - Facade's Articulation: Applied Facade - Mayfair House in London, UK (source: http://www.archdaily.com/).....	74
Fig.6.43 - Facade's Articulation: Printed Facade - Utrecht University Library in Netherlands (source: www.e-architect.co.uk/).....	75
Fig.6.44 - Facade's Articulation: Stacked Articulation - South Asian Human Rights Documentation Centre, New Delhi (source: http://anagramarchitects.com/).....	75
Fig.6.45 - Facade's Articulation: Juxtaposed Articulation - Aquacenter in Mantes La Jolie, France (source: http://www.e-architect.co.uk/).....	75
Fig.6.46 - Facade's Articulation: Web Articulation - French Pavilion in Expo Shanghai 2010 (source: www.assets.inhabitat.com).....	75
Fig.6.47 - Facade's Articulation: Layered Articulation - Dior Ginza, Tokyo (source: http://archidose.blogspot.pt/2013/).....	76
Fig.6.48 - Facade's perforations of Dior Ginza (source: http://www.arcspace.com/).....	76
Fig.6.49 - Facade's Material: Metal, an example of a perforated facade - Het Bushok in Netherlands (source: www.archilovers.com).....	77
Fig.6.50 - Facade's Material: Metal, an example of a facade with a complex geometry - Soumaya Museum in Mexico City (source: http://www.archilovers.com/).....	78
Fig.6.51 - Facade's Material: Glass, an example of a printed facade - Historical Archive of the Basque Country in Bilbao, Spain (source: http://www.archilovers.com/).....	78
Fig.6.52 - Facade's Colors: Pictorial Color, The Bisazza Foundation in Alte di Montecchio Maggiore, Italy (source: http://www.archilovers.com/).....	78
Fig.6.53 - Facade's Color: Random Color, The Museum Brandhorst in Munich, Germany (source: http://www.archilovers.com/).....	79
Fig.6.54 - Image Synthesis of the Facade's Classification: The names in the dark grey rectangles are the Dimensions and the names in the corresponding light grey rectangles are the options for each dimension.....	80
Fig.7.1 - Phography of the Campus Netzwerk Office, Germany (source: www.dezeen.com).....	82
Fig.7.2 - Hexagonal Perforations of the Campus Netzwerk Office (source: http://static.dezeen.com/).....	83

Fig.7.3 - Photography of the Stazione Mediopadana in Bologna (source: www.archilovers.com).....	83
Fig.7.4 - Photography of Gantenbein Vineyard (source: http://www.gramaziokohler.com).....	84
Fig.7.5 - Photography of the Cascais House in Cascais, Portugal (source: http://www.archilovers.com/).....	86
Fig.7.6 - An image of the facade where it is visible the concrete slabs with different sizes and the produced empty spaces (source: http://guedescruzarquitecto.wix.com/pt).....	86
Fig.7.7 - Photography of the Quality Hotel Friends, in Sweden (source: www.archdaily.com).....	87
Fig.7.8 - Photography of the Suzhou SND District Urban Planning Exhibition Hall in China (source: http://www.archdaily.com/)	88
Fig.7.9 - Photography of Utrecht University Library (source: www.archdaily.com).....	89
Fig.7.10 - Image of Louis Vuitton Shop in Tokyo (source: www.dezeen.com).....	90
Fig.8.1 - Photography of the Library of Birmingham (source: http://www.archilovers.com/).....	93
Fig.8.2 - Scheme of the rings distribution.....	94
Fig.8.3 - Division of the facade's pattern into squares.....	94
Fig.8.4 - The facade's element is composed by four arcs, which are represented in four different colors.....	94
Fig.8.5 - The subtraction of two surface arcs. The left arc has a bigger radius than the middle arc. The subtraction of the middle arc from the left arc creates the arc on the right — a ring.....	94
Fig.8.6 - Scheme of an element's extrusion.....	95
Fig.8.7 - A photography of the facade's rings: Along the radius of a black ring, it fit three golden rings (source: http://www.archilovers.com/).....	95
Fig.8.8 - A layer of overlapped rings.....	97
Fig.8.9 - The overlapping of the two layers of rings.....	98
Fig.8.10 - Example of the production of the Library's model with the different layers.....	99
Fig.8.11 - The model's structure: the definition of the main volumes, points (P P1 and P2) and the function's parameters — length, width and height.....	99
Fig.8.12 - The Library's Model: generated with the first set of parameters (table above).....	100
Fig.8.13 - The Library's Model: generated with the second set of parameters (radius=15m).....	101
Fig.8.14 - The Library's Model: generated with the third set of parameters (radius=30m).....	101
Fig.8.15 - The Library's Model: generated with the fourth set of parameters (table above).....	102
Fig.8.16 - The Library's Model: generated with the parameters summarized in the table above.....	103

Fig.8.17 – The Library’s Model generated with the set of parameters in the table above.....	103
Fig.9.1 - An image of a pattern produced by the classification in the table.9.1.....	107
Fig.9.2 - An image of the pattern produced by the classification in the table.9.2. (with an Alternated-Grid distribution).....	107
Fig.9.3 - An image of the pattern produce by the classification in the table.9.3. (with a Chess-Grid distribution).....	108
Fig.9.4 - An image of the pattern produced by the classification in the table.9.4.– with a Pictorial Size variation.....	108
Fig.9.5 - An example of a facade generated through the framework operations: Straight facade; pictorial elements with increasing sizes; regular-grid distribution; Color gray and juxtaposed surface.....	109
Fig.9.6 - An example of a facade generated through the framework operations: Straight facade; pictorial elements with random sizes; regular-grid distribution; Color gray and juxtaposed surface.....	110
Fig.9.7 - An example of a facade generated through the framework operations: Straight facade; pictorial elements with increasing sizes; recursive-grid distribution; Color gray and juxtaposed surface.....	111
Fig.9.8 - An example of a facade generated through the framework operations: Layered facade with undulated geometry, where each layer is composed by a juxtaposed surface; pictorial elements with increasing sizes; chess-grid distribution; Color black for the first layer and gray for the second.....	112
Fig.9.9 - An example of a facade generated through the framework operations: Straight facade; pictorial elements with increasing sizes; chess-grid distribution; Color gray and juxtaposed surface.....	113
Fig.9.10 - An example of a facade generated through the framework operations: Layered facade with undulated geometry, where each layer is composed by a juxtaposed surface; pictorial elements with increasing sizes; chess-grid distribution; Color black for the first layer and gray for the second.....	113
Fig.9.11 - An example of the pattern application on a cylindrical surface.....	114
Fig.9.12 - An example of the pattern application on a horizontally undulated surface.....	114
Fig.9.13 - An example of the model produced by the function <i>surfaceGeometry</i>	117
Fig.9.14 - An example of the model produced by the function <i>regularGrid</i>	117
Fig.9.15 - Synthesis of the generation process of the Quality Hotel Friends' facade: The subtraction of the elements (middle image) from the facade’s surface (image on the left) generates the final model of the Quality Hotel Friends (image on the right).....	117
Fig.9.16 - An example of the Quality Hotel Friends facade produced by us: with 13X25 windows, the attractor point is (15 0 60) and the magnitude is 4	118
Fig.9.17 - An example of the Quality Hotel Friends facade produced by us: with 20X37 windows, the attractor point is (15 0 60) and the magnitude is 4	119
Fig.9.18 - An example of the Quality Hotel Friends facade produced by us: with 13X25 windows, the attractor point is (15 0 60) and the magnitude is 2	119

Fig.9.19 - An example of the Quality Hotel Friends facade produced by us: with 13X25 windows, the attractor point is (15 0 60) and the magnitude is 5	119
Fig.9.20 - An example of the Quality Hotel Friends facade produced by us: with 13X25 windows, the attractor point is (30 0 15) and the magnitude is 4	120
Fig.9.21 - An example of the Quality Hotel Friends facade produced by us: with 13X25 windows, the attractor point is (22 0 37) and the magnitude is 4	120
Fig.9.22 – The attractor line and its effect on the surrounding geometries.....	122
Fig.9.23 – The end result of the function <i>alternatedGrid</i>	122
Fig.9.24 - An example of the Campus Netzwerk Office similar to the original facade.....	123
Fig.9.25 – An example of the Campus Netzwerk facade with the attractor-line at its bottom.....	124
Fig.9.26 – An example of the Campus Netzwerk with the attractor-line placed in the diagonal.....	124
Fig.9.27 – An example of the Campus Netzwerk with the attractor-line in the facade’s center but with the magnitude’s value inverted.....	125
Fig.9. 28 – An example of the Campus Netzwerk Office with a sinusoidal attractor-line.....	125
Fig.9.29 – An example of the Campus Netzwerk Office with a sinusoidal attractor-line with inverted magnitude.....	125
Fig.9.30 – An example of Campus Netzwerk Office with half the perforations.....	126
Fig.9.31 – An example of Campus Netzwerk Office with circular perforations.....	127
Fig.9.32 - Photography of the House AAG (source: www.archilovers.com/).....	127
Fig.9.33 - The placement of the cylinders: they are placed at the points where the stripes have their maximum amplitude.....	128
Fig.9.34 - Representation of the facade’s articulation: the metal stripes are placed horizontally and side by side and the cylinders are placed vertically.....	129
Fig.9.35 - The model of the House AAG with a size of 7.5x5.3m, with 80 horizontal stripes of frequency=8 and amplitude=0.06m	130
Fig.9.36 - The model of House AAG with 30 metal stripes.....	131
Fig.9.37 - The model of House AGG with 130 stripes.....	131
Fig.9. 38 - The model of the House AAG with an amplitude of 0.14m.....	132
Fig.9.39 - The model of the House AAG with an amplitude of 0.02m.....	132
Fig.9.40 - The model of the House AAG with a frequency of 5	133
Fig.9.41 - The model of the House AAG with a frequency of 11	133

Fig.9.42 - The parameters of the brick: Height, Width and Length.....	134
Fig.9.43 - The stacking of the bricks in an alternated-grid.....	134
Fig.9.44 - Photography of purple balls (source: http://www.candymachines.com/).....	134
Fig.9.45 - The pattern created by the rotated bricks (above) and the picture selected for the function <i>pictorialRotation</i> (bellow).....	135
Fig.9.46 - The model of the Gantenbein Vineyard with 19m of length and 5m of height.....	135
Fig.9.47 - The model of the Gantenbein Vineyard with bricks placed backward and forward.....	136
Fig.9.48 - The model of the Gantenbein Vineyard with squared perforations.....	137
Fig.9.49 - The model of the Gantenbein Vineyard with circular perforations.....	137
Fig.9.50 - The model of the Gantenbein Vineyard with squared Appliques.....	138
Fig.9.51 - The model of the Gantenbein Vineyard with circular appliques.....	138
Fig.9.52 - The positioning of the cylinders in order to create the grid.....	139
Fig.9.53 - The model of the Gantenbein Vineyard with a grid producing the facade pattern of the grapes.....	139
Fig.9.54 - A Rendering of the FACIM WaterFront Project by Bak Gordon (source: http://www.bakgordon.com/200_projects/)	140
Fig.9.55 - The African Motif that inspired the pattern.....	140
Fig.9.56 - The gradation of the skin's pattern: each module corresponds to a different scale and the modules are organized in descending order of scales.....	141
Fig.9.57 - The pattern fragmentation into parts to find the element base.....	141
Fig.9.58 - The pattern element.....	141
Fig.9.59 - The overlapping of two grids of elements: elements distribution in Alternated-Grid.....	141
Fig.9.60 - The tower with the increasing size variation along its length.....	142
Fig.9.61 - The pattern with a horizontal increasing size variation.....	142
Fig.9.62 - An example of a tower's skin with an increasing size variation along its height.....	142
Fig.9.63 - An example of a tower's skin with a decreasing size variation along its height.....	142
Fig.9.64 - An example of a tower's skin with an attracted size variation: the attractor-point is placed approximately in the facade's center.....	143
Fig.9.65 - An example of a tower's skin with an attracted size variation: the attractor-point is placed on the facade's left side.	143

Fig.9.66 – An example of a tower’s skin with a sinusoidal attractor-line.....	144
Fig.9.67 – An example of the tower’s skin with a Cylindrical geometry.....	145
Fig.9.68 – Three examples of the tower’s skin with Sinusoidal and Co-sinusoidal geometries.....	145
Fig.10.1 – False Ceiling: Bar Bô Zen in Braga by Central Arquitectos (source: http://centralarquitectos.com/).....	147
Fig.10.2 – False Ceiling: Hexcell Fabric Ceiling, Heavybit Industries, Lisa Iwamoto & Craig Scoot.....	147
Fig.10.3 – False Ceiling: Common Weathers NYSCI, SOFTLab (source: http://softlabnyc.com/).....	148
Fig.10.4 – The pattern generated by using our framework.....	148
Fig.10.5 – Tsujita LA Ceiling by Takeshi Sano: An image of clouds produced by wooden sticks with different lengths (source: www.contemporist.com).....	148
Fig.10.6 – Jeff Dah-Yue SHI design: An interior with the same pattern on all the surfaces (source: www.plataformaarquitectura.cl).....	149
Fig.10.7 – Interior Walls: Roka Akor SF Bar Wall, Matsys Design (source: http://matsysdesign.com/).....	149
Fig.10.8 – Interior walls and ceiling: M.A.C YQ Store, Lisa Iwamoto & Craig Scott (source: http://www.iwamotoscott.com/).....	149
Fig.10.9 – Parametric pattern on a restaurant’s counter: Oliva Palito Coffe Shop by DigitalLAB (source: www.facebook.com/digitalab.pt).....	149
Fig.10.10 – Screen wall pattern: Uniopt Pachleitner Group Headquarters by GS Architects (source: www.archdaily.com).....	150
Fig.10.11 – Parametric Stair Rail + Corian screen by MARCC FORNES/THEVERYMANY (source: http://theverymany.com/).....	150
Fig.10.12 – Stair Rails (www.architonic.com).....	150
Fig.10.13 – Carpets: River Rock Carpet by Bev Hisey (http://www.mocoloco.com/).....	151
Fig.10.14 – Furniture: Voronoi Chair by Torabi Architect (source: http://www.torabiarchitect.com/).....	151
Fig.10.15 – A site specific installation for the San Gennaro North Gate, in New York, designed and produced by SOFTLab (source: http://softlabnyc.com/).....	151
Fig.10.16 – Vousoir Shell project by Lisa Iwamoto & Craig Scott to the Artists Space Gallery, New York, 2008 (source: http://www.iwamotoscott.com/).....	151
Fig.10.17 – Louis Vuitton Pop-up Store in Selfridges, London, by Marc Fornes/THEVERYMANY, 2012 (source: www.theverymany.com).....	151
Fig.11.1 - Synthesis of the models produced based on real facades with their corresponding classification and real project... 155	155
Fig.11.2 – A set of several different patterns developed using our framework.....	156
Fig.11.3 – MODEL 1: Straight surface, circular elements, fixed sizes, regular distribution.....	159

Fig.11.4 - MODEL2: Straight geometry, circular elements, increasing size, alternated-grid distribution.....	160
Fig.11.5 – CHANGING MODEL1: changing the type of size variation of the circles to became attracted to one point.....	161
Fig.11.6 – CHANGING MODEL1: changing the elements’ geometry and the type of size variation.....	161
Fig.11.7 – MODEL 3: in this section this model is used to prove the portability of our framework.....	163
Fig.11.8 – A print screen of the environment of DrRacket, with the corresponding backend. We simply have to write the name of the software that we want to use to change the environment backend.....	163
Fig.11.9 – Print Screens of three different environments with the same model: AutoCAD, REVIT and Rhino5.....	164

LIST OF TABLES

Table7.1 - Synthesis of the classification of eight projects. Left column: the projects. Other columns: the dimensions and the corresponding coordinate of each project.....	91
Table9.1 – Classification synthesis of the Example1.....	106
Table9.2 – Classification synthesis of the example 2.	107
Table9.3 – Classification synthesis of the example in Fig.9.3.....	107
Table9.4 – Classification Synthesis of the example in Fig.9.4.....	108
Table9.5 - Classification synthesis of the example4.....	109
Table9.6 - Classification synthesis of the example in the Fig.9.6.....	110
Table9.7 - Classification Synthesis of the Example3.....	111
Table9.8 - Classification synthesis of the example in Fig.9.8.....	112
Table9.9 - Classification synthesis of the example in Fig.9.9.....	113
Table11.1 – The generation time of each model present in Fig.10.2: the first column has the corresponding pattern’s number; the second columns the time needed for the classification; the third columns the time spent in the algorithmic implementation; the forth columns has the model’s generation time using the AutoCAD software; the fifth columns has the total generation time	157
Table11.2 – The models generation time using both traditional and algorithmic approaches.....	162

ABBREVIATIONS

CAD – Computer Aided Design

CAM – Computer Aided Manufacturing

CNC – Computer Numerical Control

GD – Generative Design

GS – Generative System

NURBS – Non Uniform Rational Basis Spline

PM – Parametric Model

SG – Shape Grammars

GLOSSARY OF TERMS

Facade – The outer layer of a building, which can be structural or non-structural.

Generative Design – A design process through which several potential design solutions can be created determined by algorithms, normally by using a computer program.

Generative System – A system that generates possible solutions for design problems.

Traditional approach for using CAD tools – An approach to design in which CAD tools are used to represent or conceive a design based on abstract models produced with explicit modeling operations.

Algorithmic system – An approach to design that is controllable and can easily handle change, which allows the generation of several different variations of the same design.

Parametric Design – A design process based on algorithmic thinking that enables the expression of parameters and rules that, together, define, encode and clarify the relationship between design intent and design response.

Design Instance – One possible variation of a parametric design.

Design Parameters/Variables – Values or design properties that can be edited to manipulate or alter the end result of a design.

Program – A formal representation of a design. An algorithm written in a way that the computer understands (a programming language) with specific and rigorous instructions that tells the computer what specific steps to perform.

Programming – The act of translating algorithms into a programming language so that they can be performed by the computer.

Performative Architecture – An architecture that uses digital technologies to challenge the way the building environment is designed.

Kinetic Architecture – A concept through which buildings are designed to allow parts of the structure to move, without reducing the overall structural integrity.

INTRODUCTION

Since the origins of Architecture that ornament has been used as a connection between nature and the society's culture. The prehistoric man already adorned his cave walls with drawings, which transmitted messages and gave meaning to the primitive ornamentation. Since the Classic epoch, along the Romanesque and Gothic periods and reaching the periods of Neoclassic and Revival in architecture, it is noticeable that ornament was always present in a more or less exuberant way. Ornamentation has been carrying out values throughout History, such as symbolism, function, space and culture. In addition, ornament has given meaning to architecture by creating architectural "moments" (McNicholas, 2006). With the arrival of the 20th century, ornament began to disappear from architecture. With the support of some theorists, among them Adolf Loos with his famous work "Ornament and crime", Modern Architecture became undressed of ornament and obsessed with transparency (Moussavi & Kubo, 2006), without unnecessary detail and where "Form follows function", as Louis Sullivan described. This position was later criticized by the post-modernisms, which appealed for an architecture with meaning that communicated with the cities and the citizens (Venturi, 1966) and that accompanied the times that were being experienced.

The interest and disinterest in ornament is directly related with the status of the architectural Facade which, although considered an important element until the turn of the 20th century, lost its status with the birth of Modernism. Nowadays, the Facade is reassuming an important role, in large part, due to the use of digital technologies (Pell, 2010).

Architecture has always followed the times and their innovations and, currently, an architecture based on digital technologies has been emerging and has increasingly explored architectural skins, which is visible in the latest buildings with attractive facades full of complexity and new patterns. The development of CAD tools has had an important role in the generation of these contemporary skins because they allow the constant exploration of new shapes and patterns, which would not be viable to produce manually. In addition, they also increase the design efficiency and their evolution has been changing, not only the design process, as also the architectural thinking (Kolarevic, 2003).

This emphasis on building skins with complex geometries requires a design process that allows change, experimentation and rapid visualization of different results. Unfortunately, the traditional design tools do not properly support the increased complexity of current facades, nor the continuous experimentation and testing of ideas, as they require too much effort and time to change models. The manual labor of the past using a large number of highly skilled men to produce splendid historic facades is not viable nowadays, because it becomes extremely expensive. The computer became a very important tool of the design process which changed, and still changes, the way architects design

(Kolarevic, 2003) and, nowadays this same work can be done quickly and minutely with the use of both Generative Design (an approach to design based on algorithms) and new production techniques.

New technologies allow the design exploration to go far beyond the traditional possibilities and human imagination and it has recently focused on the reintroduction of architectural patterns and in



Fig.1 - The FACIM WaterFront project: a project of Bak Gordon Studio together with FVA and PROAP for the city of Maputo, Mozambique (source: www.bakgordon.com)



Fig.2 - An image of the towers' interior with the patterned skin visible (source: Bak Gordon's Studio)

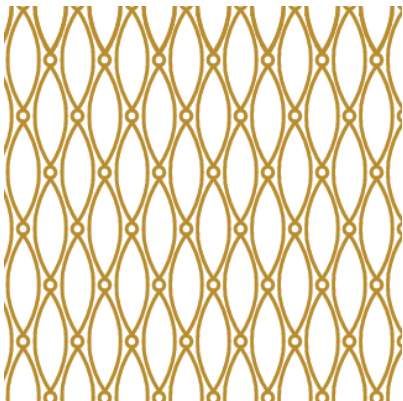

Fig.3 - The skin pattern based on African motifs (source: Bak Gordon's Studio)

the rebirth of building skins. Nevertheless, there are still some limitations in the architectural practice, mainly in the production of more complex designs. This situation frequently forces the architect to keep the first solution that was produced, because it would take too much time to generate a variation of the same design. We had the good fortune of witnessing this situation on a visit to Bak Gordon's Studio, in Lisbon. The architect showed us a project for Maputo — the FACIM WaterFront Project (Fig.1) — which consisted of a set of towers, where the skin of the towers (Fig.2) had a pattern inspired in African motifs (Fig.3). The skin consisted of several metallic profiles shaped in order to produce a pattern where the repeated element became gradually smaller along the facade's length. However, the architect was not entirely satisfied with the final result and he would like to have tested other possible variations for the tower's skin, but postponed the idea because it would have taken too much time and effort. This situation became the problem we would like to solve. As we will show the solution required the development of a framework for the generation of buildings skins that was easy to use and also allowed the user to quickly change a design, in order to experiment several results.

In this thesis, we discuss the development of a computational framework for the design of facades and we present two important contributions. The first contribution is a classification of facades into different categorical dimensions that we consider computationally relevant, which was based on an analysis of a large corpus of contemporary facades. The second contribution is the identification and implementation of a set of algorithms and strategies that address the needs of the different dimensions.

We called this framework DrAFT - Draft Algorithmic Facades Tool. We use generative design as the basis for this framework and we intend to reduce the initial time investment required when using this type of design approach, specifically in the production of building skins.

In an initial phase, we did a research of several contemporary buildings and, then, we organized the buildings according to each facade's typology. For this organization, different categories were considered in specific design stages: (1) the definition of the facade's geometry; (2) the generation and transformation of the facade's elements; (3) the distribution of elements; and (4) the facade's final appearance. Based on these stages, we structured a classification composed by several categorical dimensions that are relevant from the computer point of view, which were organized in order to incorporate the stages of the programming scripting structure.

The first stage explores the Facade's Geometry dimension, which produces parametric geometries instead of static and inflexible geometries.

The second stage includes three dimensions: the first dimension-Element's Geometry-is responsible for producing the shape of the facade's elements, allowing different geometric shapes; the second dimension-Element's Deformation-is responsible for changing the elements' shape, including twisting, undulating, bending and interlacing; the third dimension-Element's Size-is responsible for varying the size of the facade elements.

The third stage includes two dimensions, one-Element's Distribution-responsible for mapping the elements and the other-Element's Rotation-responsible for rotating them. The mapping establishes a correspondence between locations in the facade surface and the placement of the facade elements and is organized in three sub-groups: (1) mappings with one parameter, which occur when a surface is divided along one axis, (2) mappings with two parameters, which occur when a surface is divided on two orthogonal axes, and (3) mappings with three parameters, which includes a third axis corresponding, for example, to the passage of time in animated or kinetic facades.

The last stage is concerned with the facade's final appearance, and includes two dimensions. The first dimension-Facade's Articulation-produces the facade's finish, allowing for facades that are perforated, painted, with applied elements, etc. The second dimension-Material & Color-defines the materials and colors to apply.



So, for each design stage, this classification explores one or more dimensions, which are composed by a set of algorithms that represents the range of possibilities available. This classification generates a

multi-dimensional space where an entire facade or parts of a facade can be located. The second important contribution of our work then comes from the elaboration of a set of fundamental algorithms and strategies that address the needs of the different dimensions of this space. Some of the locations in this multi-dimensional space can use a specific computing approach that is adequate for the creation of the designs that match the intended facade. Other locations, representing less common kinds of facades, might not have a specific computational solution, but our experience shows that it is possible, using the tools available in our framework, to quickly implement the particular solution required by that facade.

In practical terms, the end result of our research is a library of operators usable in different programming languages and a set of guidelines that helps a designer select and combine the most useful operators to implement a design for a particular facade.

As a simple example, consider a perforated facade. This facade can be classified, at the very minimum, according to the shape of the facade itself, the distribution of the perforations, and the shape of the perforations. For each of these dimensions, we provide specific algorithms that can be combined to achieve the intended result. The shape of the facade and the shape of the perforation are described by independent functions, selected (or implemented) by the designer. The distribution of the perforations and its application to the shape of the facade is achieved by the functional composition of these functions.

Our work is implemented using Rosetta, a programming environment for generative design, allowing us to explore the generation of facades in common CAD applications, thus promoting the integration of the generative design approach in a more traditional working environment.

Our proposal does not exclude other approaches for the design process, it is simply an additional stage specialized in the generation of buildings skins. Instead, it allows the designer to go further in the exploration of different design solutions to apply on architectural facades, such as complex geometries, intricate patterns and new textures.

OBJECTIVES

The main objective of this dissertation is to develop a methodology that helps architects in the generation of facades by using an algorithmic approach to design. We explore and evaluate the different design stages that constitute an algorithmic-based design approach, more specifically, for the generation of building skins, and based on those stages, we propose a classification of facades. The aim of the classification is to help designers in the selection of the algorithms that better suit their design intent.

Our approach is evaluated both on several case studies already constructed and on more abstract examples idealized by us. The selected case studies have either a particular skin pattern or an unusual texture or shape. The application of the framework on each of the case studies also shows how to easily change the original design, whether it is a small or a large change, with repercussions in all the design parts, such as geometry, number of elements, size, etc.

The construction of our framework has three main goals:

1. Create a classification of facades that organizes the design process into substantial phases that guide the selection of the algorithms that better suit each design intent.
2. Provide several pre-defined functions to generate different design solutions of facades.
3. Inspire a future wider framework (with more design options) from which architects can select functions already defined. In addition, it would be possible to implement other functions that meet more specific design solutions and add them to the framework, so it becomes increasingly more complete.

METHODOLOGY

We followed a methodology based on four main phases: (1) literature review, (2) explanation of the framework's strategy and a detailed description of the classification, (3) practical application of the framework, (4) evaluation and conclusions.

The first phase, the literature review, consists in a review of bibliography focused on the relevance of the architectural facade, on new architectural expressions and on new design tools, particularly Generative Design. The research allowed the understanding of the connection between (1) the building skins and new ornamentations and (2) the emerging paradigms in architectural practice, such as parametric architecture and performative architecture, and (3) the tools that allowed this fusion, like Generative Systems.

The second phase starts with the motivation of the framework and the explanation of the process behind the classification of facades. We explain the structure of the classification, which was divided in

several categorical dimensions, and we describe each dimension's functionalities and the pre-defined functions provided. In the end, we summarize all the dimensions to present an overview of the classification's possibilities.

The third phase starts with some practical examples of the application of the classification on existing building skins. Then, we explain the process behind the generation of a facade design and we divide it in four phases: from the stage of the design analysis to the experimentation of the model's possible instances. For this, we use an existing building as an example, the Library of Birmingham. We follow with a practical application of the framework, first in the generation of abstract examples and, then, in the generation of real examples. In the end, we suggest other possible applications for our framework, besides the generation of facade's models.

The last phase, the evaluation and conclusions, starts with the review of the work developed and, then, we evaluate our framework and compare to other existing applications. In the end, based on the evaluation, we present the conclusions and the future work.

STRUCTURE

This dissertation is divided into two main parts: I. *Background* and II. *A Framework for the generation of Contemporary Facades*. We also added to these two parts the Introduction, Conclusions and Bibliography sections.

The **Background** is divided in four chapters:

- 1 Ornament** | In this chapter we define ornament, decoration and pattern. We analyze the presence of ornament and its theoretic evolution in the history of Architecture.
- 2 The Contemporary Facade: New Expressions in Architecture** | In this chapter we focus on the status and evolution of the architectural facade. We also describe some of the contemporary expressions in the architecture field, like performative, parametric, adaptive, and kinetic architecture.
- 3 New Technologies** | In this chapter we define Generative Design (GD), the beginnings of Generative Systems in architecture and their maturity. We explain the main characteristics of several GSs, such as Algorithmic Systems, Parametric Systems, Shape Grammars, Genetic Algorithms, Cellular Automata and L-Systems.
- 4 Generative Design: Architectural Practice** | In the last chapter of this part we characterize some of the strategies that are being used to apply GD in architectural practice. We also include two case studies of well-known and documented projects, the Aviva Stadium and Water Cube, which are examples of an integrated approach in which GD was used from the initial stage of the project to its construction.

The Second part of this dissertation, **A Framework for the Generation of Contemporary Facades**, is divided in seven chapters:

- 5 Introduction** | In this chapter we reintroduced the main objective of this dissertation to contextualize the second part.
- 6 Algorithmic Facades** | In this chapter we introduce the framework and we structure the classification for facades. We explain the inspiration and the main objective of the classification and we describe in detail all the categorical dimensions that constitute the classification. In the end we summarize all the classification in a single table, in order to promote an overview of its whole structure.
- 7 The Application of the Facade's Classification** | In this chapter we classify several existing facades in order to promote a better understanding of how the classification works.
- 8 Facades Generation Process** | In this chapter we pick the Library of Birmingham project as an example on which we explain the whole process behind the generation of a building's skin. This process was divided into four phases: (1) design analysis, (2) the application of the classification, (3) the implementation of the algorithms to generate the model and (4) the variation of the model's design.
- 9 The Generation of Contemporary Facades** | In this chapter we apply the algorithms available within the framework to generate some example of building skins. We produce a first set of more abstract skins, because we aim to explain how to use the classification and the corresponding algorithms in the generation of a facade's design. The second set of facades that we generate corresponds to real projects, which we try to reproduce and, then, use to experiment other design possibilities.
- 10 Other Applications** | In this chapter we suggest other applications for our framework, more specifically in interior design.
- 11 Evaluation** | In this chapter we evaluate our work in several stages: we start by evaluating (1) the flexibility of our framework, i.e. its capacity to generate a wide range of possible designs for facades. Then, we analyze (2) its advantageous use comparing with the traditional approach, i.e. how fast and easily we can generate models using the framework, and finally (3) its portability, i.e. its capacity to be used with different CAD tools.

PART I

BACKGROUND

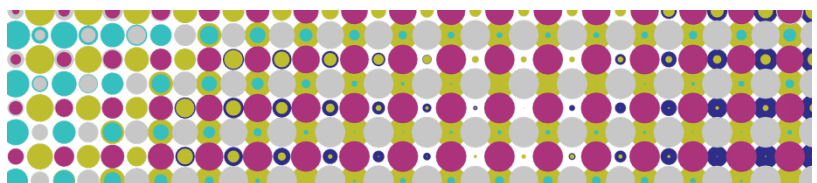
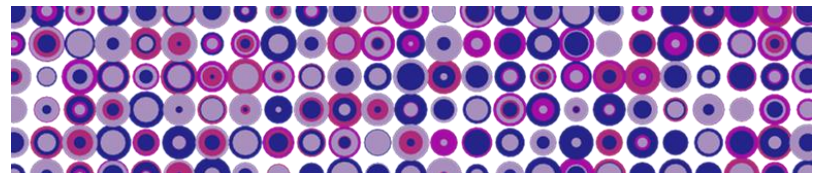
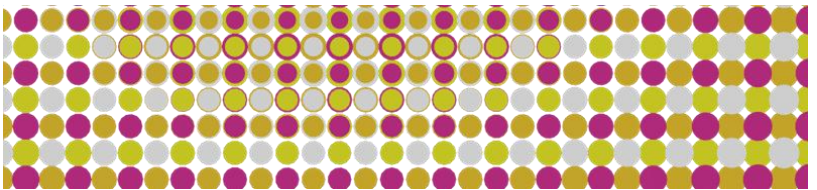
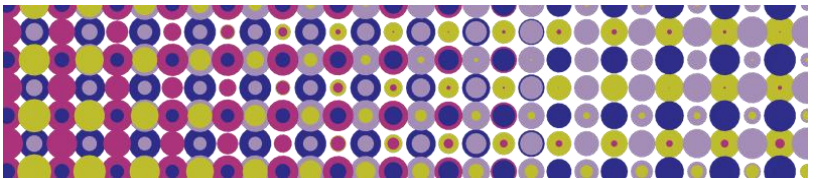
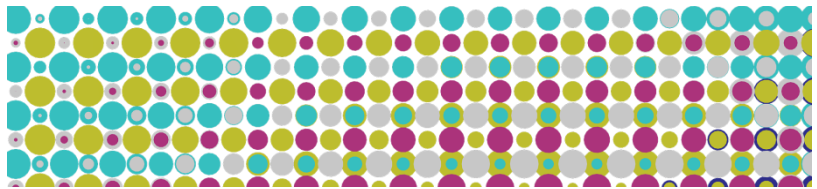
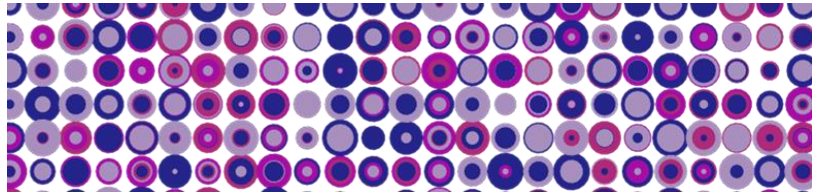
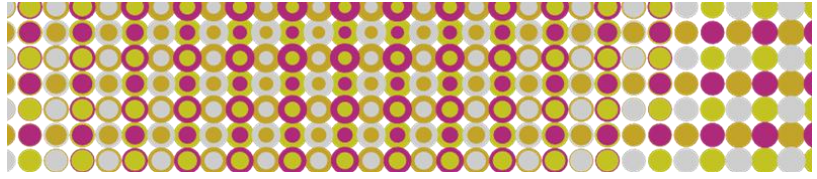

1 ORNAMENT

1.1 ORNAMENT, DECORATION AND PATTERNS

"Pattern, decoration, [and] ornament attaches people to things."

— (Phillips, 2003)

Derived from the Latin "ornare", ornament means to honor or adorn, and can be also described as a manifestation of beauty (McNicholas, 2006). It is placed in the middle of two opposing ideas: the first defends that ornament is merely an addition, ergo superfluous, to something functional in order to make it more attractive. The second states that ornament is intrinsic to something and that it is through ornament that beauty is experienced (Fig.1.1).

Decoration derives from the Latin word "*decoratio*", from which later resulted the French word "*décoration*" and then middle English word "decoracioun". Decoration is a temporary embellishment (McNicholas, 2006) and it is important to distinguish between ornament and decoration. Both ornament and decoration secure visual pleasure and beauty, but decoration implies less consequences because it can more easily be changed or removed.

Like decoration, pattern is also an element inside the framework of ornament. The word pattern derives from the Medieval Latin word "*patronus*", which later originated the French word "*patron*". Pattern can be defined as a repeated decorative design, which usually conveys rhythm or movement, with a great connection to mathematics, because pattern is leaded by rotation and symmetry (Beeby, 1977) (see Fig.1.2).

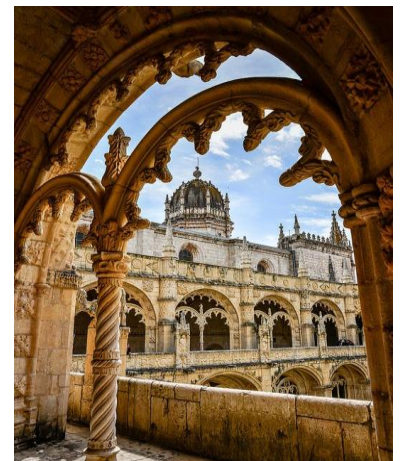

Fig.1.1 - Manueline Ornamentation in the cloisters of Jerónimos Monastery in Belém, Portugal (source: www.pinterest.com/pin)



Fig.1.2 - Patterns in Architecture: Portuguese Tiles (source: www.pinterest.com/pin)

1.2 ORNAMENT IN ARCHITECTURE



Fig.1.3 - Baroque: the Queen's room in the Versailles Palace (France). The ornamentation exuberance is very characteristic of this style (source: www.en.wikipedia.org/wiki/Palace_of_Versailles/)



Fig.1.4 – Roman Empire: Statues were used to ornament temples (source: www.2020site.org)



Fig.1.5 – Rossio Station's in Lisbon: the doors are ornamented so as to recreate the Portuguese Manueline style (source: <https://www.flickr.com/>)

Throughout history, ornament was used in buildings, both on the exterior and the interior (Fig.1.3), to enhance and amplify presence and appearance, give scale and texture through intricate treatment of surfaces. Ornamentation and aesthetics composition have been explored in several ways along history, where buildings were related to the corresponding culture (Schimek, et al., 2008), which created sensations and affects. In addition, ornamentation had largely a symbolic function by embodying values and ideals that defined a particular culture, simultaneously acting as a symbolic construct and enabling the construction of symbolic meaning (Kolarevic & Klinger, 2008).

Since a long time ago, architecture and ornamentation have been interconnected in the expression of the different styles. The increasing and decreasing use of ornamentation has been linked with the meaning of the word *Ornament* itself, which has been constantly redefined. The word ornament has always had a two-sides existence in architecture. From one perspective, ornamentation is the strongest giver of meaning in architecture but from another perspective, ornament is dysfunctional, having no function (Heikkinen & Kareoja, 2011). Its past and current use in architecture has long provided fuel for discussions and debates about the architectural aesthetics (Miller, 2011). Ornament could be defined as the elaboration of functionally complete objects for the sake of visual pleasure or cultural significance, and its use on buildings was like an instrument of differentiation (Miller, 2011).

Historically, the aesthetic effect of the ornamentation on buildings has been explored and analyzed in various ways, where it has been used as a reference to traditions and as a representation of hierarchy. Since Man began to build, thousands of years ago, he started to produce architecture in its simplest form and, already in the Roman and Greek Empire (Fig.1.4), ornament was intrinsic in architecture, reaching then its peak of exuberance in the 18th century's Rococo style. Ever since architecture has always been connected to culture and also capturing the forces that shaped society in each time. It is also through ornamentation that architecture communicates values and

ideologies, thus being only natural to find a strong dependence between ornament and the cultural context. Eliminating ornament from architecture erases the values associated with it (Heikkinen & Kareoja, 2011).

"I see ornament in architecture as having a dual function. On the one hand it offers support to the construction and draws attention to the means it employs; on the other... it brings life into a uniformly illuminated space by the interplay of light and shade."
— Henry Van de Velde, 1902

The activity of Architecture was developed along the centuries, with its beginnings in earth, wood and stone constructions, until 21st century's high technology construction and new materials. This evolution has taken a long and complex path until today. Ideological and technological processes are the major driving forces of any field including architecture, but there are many other important catalysts, such as cultural, social and religious aspects of the different eras, education and new ways of living and building the city. Progress in architecture has always followed the development of human life, since it is on this that the architectural practice is founded and is reflected.

A certain pattern was generally the unfolding of a new architectural style, and all new styles ended up contrasting with the previous one. After the massive and ashamed Romanesque style, came the flamboyant and detailed gothic speech, which was followed by the balanced and harmonious Renaissance era. Then, the theatrical rhetoric and exuberance of the Baroque arrived, which was softened by the following sober neoclassical style (Heikkinen & Kareoja, 2011). All these styles and even Art Deco, which already stepped in at the beginning of the 20th century, were strongly connected with ornament and, indeed, the use of ornament in European architecture was a requirement until the end of the 19th century (Heikkinen & Kareoja, 2011) (Fig.1.5).

Additionally, ornament was theorized and was the main topic of several works of authors such as Gottfried Semper, Owen Jones and Louis Sullivan. For Semper, functional and structural elements were subordinate to the semiotic and artistic goals of ornament, defending that "architecture begins with ornament" and "architecture comes to be defined in its essence as an ornamental activity" (Semper, 2004).

In the Great Exhibition of 1851, ornament had become a key topic, not only in architecture, but also in relation to design, society, industrialization, economy and taste (Bordeleau, 2009). Architects and theorists like Pugin, Ruskin and Owen agreed at the point that ornamentation constituted the main vehicle of architectural expression. Ornament was used by architects to articulate differences between spaces within the interior and to suggest the suitability of a given space for a particular type of activity (MEAGHER, et al., 2009). Then, the organic characteristics of Sullivan's buildings led to ornament, since he stated that ornament grew from the material organization and was inseparable from it.

"Ornament and structure were integral; their subtle rhythm sustained a high emotional tension, yet produced a sense of serenity."

— Louis Sullivan (Sherman, 1962)

The turn of the 20th Century was followed by the drastic decline of ornamentation and the main contributions to this situation were the industrial revolution, the standardization of the building components and the rise of the modernism style (Strehlke & Loveridge, 2005). This reduction of ornament could be directly attributed to the intensification of the use of machines in fabrication and the necessity of building in large-scale, in a cheap and fast way. Nevertheless, in the late 19th and early 20th centuries, ornamentation was ethically questioned and conceptualized as something that is additive and unnecessary (Miller, 2011).

Indeed, there were several contributions for the elimination of ornament from architecture. The first contribution was the world's new need for speed in everyday life, which consequentially was reflected in architecture and in its production. With the mass migration to the cities, the major focus was to build in quantity more than in quality and the handcrafted ornaments were considered too time-consuming and required a lot of expenditure in materials and workmanship. Currently this problem is solved by using machinery capable of producing patterns and decorative elements of high complexity, in an effective and faithful way.

The second contribution was the aesthetic philosophy of that period. Many names that today we relate with the Modernism (such as Bahaus, Deutscher Werkbund, De Stijl, Louis Sullivan, Walter Gropius) sought to reconcile the

arts and crafts with the new methods of *mass production*. In addition, Adolf Loos wrote a theory of no ornamentation in 1908, where he described ornament as a need of the primitive man, because it did not reflect the modern times and it made the buildings quickly out of style. For him, producing something that quickly would stay out of fashion was a waste of time and effort and there was no place for these things in modern society. For him the lack of decoration was a manifestation of a progressive, advanced culture (Loos, 1908), where ornamentation had lost its social function, becoming unnecessary. Consequentially, the Modern Movement believed that to be authentically "modern" one has to remove all ornament (Kolarevic & Klinger, 2008), which led to the barren surfaces of much twentieth-century architecture. To sum up, Modernists eliminated ornament to provide an architectural experience of true space (more sincere architecture) based on transparency but not on ornamentation (Moussavi & Kubo, 2006), which aimed to achieve the direct representation of architectural elements, such as space, structure and function.

Contrary to this perspective, Postmodernism architecture used ornamentation again to support the desire of communication, thus celebrating the use of ornament (Miller, 2011). The strength of mass-communication was in its apogee, and the society was influenced by the media more than ever. Postmodernists believed in an architecture that communicated its function and underlined the importance of communication in our lives. The modernism transparency was replaced for decor, thus helping the integration of buildings within the urban realm and simultaneously giving them meaning. They defended that, such as language, text, design and performance communicate with us, so does architecture and mostly through the use of ornament.

"If the structure and composition is the plot, it is the details that turn it into a tale. Only by careful detailing can we make the tale interesting and worth listening to, without that it is just an empty string of events to which we can find no emotional attachment. We can hate the ornamentation in question or we can love it, but the important thing is that it doesn't leave us cold and indifferent."

— (Frasconi, 1983)

Nowadays, due mainly "to computer technology and the growing sophistication of 3D design programs, there has been a strong re-emergence of ornament taking new and surprising forms" (Lovell, 2008). While digital technologies of parametric design and fabrication opened new possibilities for non-uniform, variable patterning and texturing of surfaces, the question of the cultural significance of such ornamental treatment of surfaces in a contemporary context also emerged (Kolarevic & Klinger, 2008). A new era of technology promoted a Contemporary architecture based on new design tools and, consequentially, the reintroduction of ornament in architecture. This exploration of patterns and decorative elements has increased due to their easy and quick generation, their effortless change and also their rapid and automatic production made directly from the 3D models (see Fig.1.6).

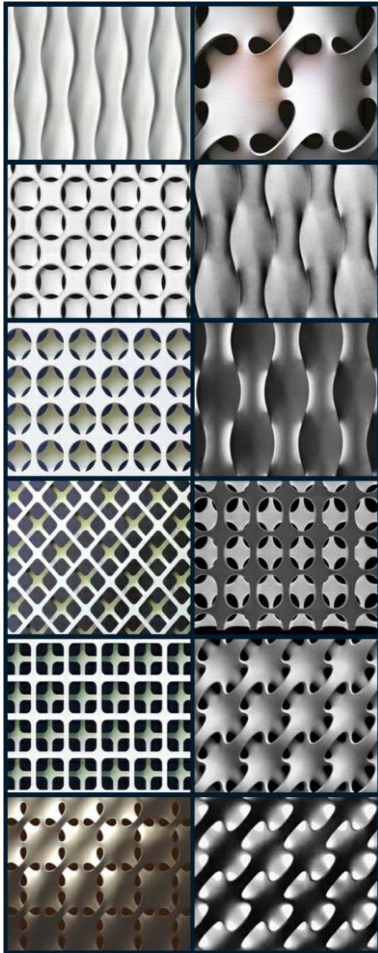

Fig.1.6 - Parametric patterns and facades: Erwin Hauer - continua architectural screens and walls (<http://www.erwinhauer.com/>)

It is therefore ironic that the return to ornament may be possible through the use of CAAD/CAAM Technologies (Strehlke & Loveridge, 2005). Therefore, in Contemporary architecture the term ornament has been redefined: some authors say that ornament is the figure that emerges from the material substrate and is inseparable and necessary in architecture, because of its effects and sensations, contributing to involuntary signification (Moussavi & Kubo, 2006); Other authors defend that ornament is no longer an additional element attached to the surface, but the surface itself or even the structure (Gavra, 2013)

In Moussavi's book *The function of Ornament*, he developed a classification for the ornament that is based on depth, material or effect, which indicates the complexity of the different approaches to the subject matter of ornamentation. In fact, we are watching a resurgence of interest in ornament over the past decade and, in part due to the evolution of digital fabrication techniques, which greatly facilitate the production of complex forms and surface patterns (Fig.1.7). This production of new types of ornaments has also been influenced by the availability of materials, which are capable of changing in response to digital information (MEAGHER, et al., 2009).

To sum up, if architecture wants to remain convergent with culture, it needs to build mechanisms through which culture can constantly produce new images and concepts rather than recycling the existing ones. There is the necessity of reevaluating the previous tools with the new conditions, such as the contemporary technology and the environmental needs that are

emerging nowadays (Moussavi & Kubo, 2006). Contemporary ornamentation rejects the superficial applications of previous architectural genres or styles and, simultaneously, seeks for a new authenticity.



Fig.1.7 - Contemporary Ornament: John Lewis department store in Leicester, UK, Foreign Office Architects (source: <http://designresearch.sva.edu/research/patterns-of-ornament-technology-and-theory-in-contemporary-architectural-decoration-2/>)

2 THE CONTEMPORARY FACADE: New expressions in Architecture

Originating from the Italian word *faccia*, which means face, and its derivative word *facciata*, the French word *façade* (and then the English word *facade*) can be defined as the exterior side or skin of a building. Before Modernism, buildings' facades were the canvas where architectural style was celebrated. On this canvas, architects imprinted their personal interpretation of the current cultural stylistic models, with their metrics and canons. With the arrival of the 20th century, architects began to diverge from the symbolisms carried by the facade and the modernism facade became an abstraction without ornament. It was with Modernism and its hygienic and austere aesthetic that the architectural task of composing a facade lost some of its prestige. As a result, the architectural facade lost its status (Pell, 2010).

After Modernism (or since Post-modernism), we have been witnessing an increasing interest in facade composition and, nowadays, designing a facade is reassuming an important role in architecture practice due, in part, to the support of digital technologies (Pell, 2010).

This trend of highly textured building envelopes celebrates, again, the ornament in architecture and the composition of architectural facades. There are historical and cultural reasons for this renewed interest, such as the reinterpretation of Modernist aesthetics, the reintroduction of symbolism and historical precedent by Post-Modernism (Venturi, 1966), and the diligent look and revisit of vernacular precedent proposed by Critical Regionalism (Frampton, 1983). However, there is also a technological reason: algorithmic approaches made it easier to conceive, deploy and adapt the design of architectural surfaces with complex and intricate textures, and differentiated levels of porosity.

2.1 FACADE: THE OUTER LAYER OF ARCHITECTURE

Over the past decade we have seen in architectural practice the re-emergence of complex shapes, intricately articulated surfaces, enclosures and structures, whose design and production were fundamentally enabled by the capacity of digital technologies to accurately represent and precisely fabricate elements of any level of complexity. Some of the buildings feature smooth forms, some are simple "boxes" with complexly patterned envelopes and some blend both approaches (Kolarevic & Klinger, 2008).

When talking about the architectural facade, its relation with the term "*Articulation*" must be clarified. With the arrival of the 21st century, the word *Articulation* comes often to follow architecture, mainly correlated with the facade element (Pell, 2010). *Articulation* is a method whereby diverse parts and elements are sewn in a whole and unique work. A high articulation occurs when we cannot distinguish the integrating parts, i.e. when the different parts fit perfectly in the whole composition through smooth transitions, transmitting fluidity and continuity. A distinct articulation highlights the strategic breaks and transitions, focusing on the independent elements.

In the case of the Guggenheim Museum in Bilbao (Fig.2.1), the structure articulation is dominated by fusion and continuity, where the design intend was to create seemingly random organic surfaces. However the design of these surfaces was ruled by the way they gather and reflect light, thus showing an interaction between the environment and the form of the building.



Fig.2.1 - Photography of the Guggenheim Museum by Frank Gehry in Bilbao, Spain (source: <http://www.guggenheim-bilbao.es/en/the-building/outside-the-museum/>)

While the Articulation of the surface has appeared at the heart of the break up between architecture and the facade, nowadays new opportunities are emerging to consolidate questions of techniques and the expression of culturally motivated content through contemporary approaches to architecture (Pell, 2010).

In the beginning of the 90's, digital design introduced a new territory in architectural innovation, where the computer became a fundamental tool. The use of digital design technologies spread through both architecture schools and professional practice and made the design communication a quick driving force of complex 3D visualizations. The use of computers in architectural design does *"not eradicate human imagination but rather extend its potential limitations...it provides the means for exploration, experimentation, and investigation in an alternative realm"* (Terzidis, 2003).

This allowed the design of complex and abstract shapes in architectural design, however, the transition of free virtual 3D creations to the real world (and its logics of both fabrication and assembly) was a very difficult challenge. The introduction of CNC fabrication technologies enabled the realization of complex projects with the help of computer guided tools, allowing architects to acquire control over the production processes due to the access to a wide range of precise technical operations. So the exploitation of ornament and materials on the facades has been increasing due to the use of CAD tools and CAM techniques.

"Exploit the tooling artifacts that the CNC machines leave on formwork and objects. This gives a highly decorative effect... the process of converting a spline mesh surface into a tool path can generate a corrugated or corduroy-like pattern of tooling artifacts on surfaces.. The decoration emerges from both the design of the spline surfaces and the conversion into a continuous tool path"

— (Lynn, 2004)

Currently many architects deal with production processes almost as easily as with the design processes. Contemporary facades have been evolving to embody both new technical sensibilities and expressive techniques, such as research on the interface between design and fabrication, two dimensions



Fig.2.2 - The Beijing National Stadium by Herzog & De Meuron (source: www.21stcenturyarchitecture.blogspot.pt)



Fig.2.3 - A digital image of the Beijing National Stadium project by Herzog & De Meuron (source: www.openbuildings.com)



Fig.2.4 - The patterned skin of the Federation Square buildings in Melbourne, Australia (2002), by LAB Architecture Studio (source: <http://www.architravel.com/>)



Fig.2.5 - The Serpentine Pavillion in London (2002) by Cecil Balmond and Toyo Ito (source: <http://www.archdaily.com/>)

that were once divided. This aesthetic shift led to a re-emergence of the discourse related to ornament and decoration, out of favor with architecture for a large part of the twentieth century (Kolarevic & Klinger, 2008). The maturation of the digital project has contributed to construct a more solid articulated facade, which allows many considerations to be part of the formwork, such as ornament figures and embellishments, decoration symbols and performative effects of materials assemblies.

This growing interest in the facades expressions is also reflected in several conferences dedicated to the facade theme, of which we highlight the *Facades Plus+* Conference and the *Advanced Building Skin* Conference.

2.2 NEW ARCHITECTURAL EXPRESSIONS

Architectural design of the late twentieth-century can be analyzed by considering some of its prevailing themes, such as mass production and information technology. New concerns influence the future of architectural and industrial design and, if any theme can characterize this new era of architecture, it is the changing of the space perception and new design's fluidity (Whalley, 2005).

Digital technology has had a profound effect on modes of architectural production. While technological change has always been a catalyst for new ideas in architecture, today, digital information technology is the essential agent of innovation in a total process of architecture (Klinger, 2008). Architecture is in the middle of a cycle on innovative adaptation, which is retooling the discipline and is adapting the architectural and urban environment to the current socio-economic era. Today's mass society, once characterized by a unique and nearly universal consumption standard, has evolved into a heterogeneous society of multitude. Contemporary architecture should be interpreted in parallel with the new scientific paradigms, in order to formulate new goals, methods and values. Contemporary architecture is addressing the demand for an increased level of architecture complexity by retooling its methods based on parametric design systems (Schumacher, 2008).

Software enables architects to manage complexly articulated designs, while digital models facilitate the exchange of information with collaborative teams, interweaving a diverse range of expertise and feedback into the design process (Klinger, 2008). In fact, contemporary architects have not rediscovered complex curving forms, they rather found new possibilities to generate and construct those shapes, by extracting information directly from the design via new processes and techniques of digital design and production (Kolarevic, 2005).

In the history of architecture, the relationship between architectural design and new technologies has always been noticeable, as seen for example in the Crystal Palace (1851) (Fig.2.6) and the Eiffel Tower (1889) (Fig.2.7). The first building was constructed to accommodate the Great Exhibition in 1851 and it dressed the technologic spirit of the Industrial age, praising the future of steel and glass buildings. The second building was constructed to be a symbolic monument of the *Exposition Universelle* in Paris (1889) and it sampled how high new buildings could reach, by using the new technologies and materials of that time. However, it still took some years for such buildings to become members of the modern city. As it happened with the Industrial Age, today's new age of information is challenging not only the way architects design, as also the way they manufacture and construct their drawings.

"Architecture depends upon its time. It is the crystallization of its inner structure, the slow unfolding of its form. That is the reason why technology and architecture are so closely related. Our real hope is that they will grow together, that someday the one will be the expression of the other. Only then will have an architecture worthy of its name: architecture as a true symbol of our time."
— (Rohe, 1953)

Digital technologies are changing the architecture practices and, with the benefits of Computer-aided Design (CAD) and Computer-Aided Manufacturing (CAM), having an effect on the architectural design and construction. New opportunities were created through the use of these technologies, thus allowing the production of complex shapes and patterns, which were very difficult and costly to design and produce until recently. This situation will have deep consequences in the architectural practice, because these new design processes, and fabrication and construction techniques are



Fig.2.6 – Image of the Crystal Palace built by Joseph Paxton in 1851 (source: www.telegraph.co.uk)



Fig.2.7 - Image of the Eiffel Tower in Paris by Gustave Eiffel (1889) (source: www.smithsonianmag.com)



Fig.2.8 - Vodafone building in Oporto (Portugal) designed by Barbosa e Guimarães Architects (2009) (source: www.21stcenturyarchitecture.blogspot.pt)



Fig.2.9 – Troia Design Hotel, Portugal, by Promontório Arquitectos (2009) (source: www.troiadesignhotel.com)

defying more and more the historic relationship between architecture and its means of production (Kolarevic, 2005).

2.2.1 NEW GEOMETRIES

"...forgotten geometries lost to us because of the difficulties of their representation." — (Moneo, 2001)

The contribution of new technologies in the architectural design and fabrication promoted the emergence of "new" geometries, i.e. more complex shapes and exhaustive details and patterns, which were rescued or introduced due to their possible production. These new shapes include biomorphic forms, amorphous forms, round forms, NURBS curves and parametric curves.

Already in the Baroque era, architects tried to overcome the Cartesian Grid and the predefined norms of beauty and proportion. As a matter of fact, biomorphic forms came from the Baroque and from the following organic vocabularies of the early and mid-twentieth century. The geometries of Art Nouveau were organic and biomorphic, as were the shapes produced by Gaudi in his highly sculptural and rigorously designed buildings, with organic geometries for which he applied a method of his own to modeling catenary curves.

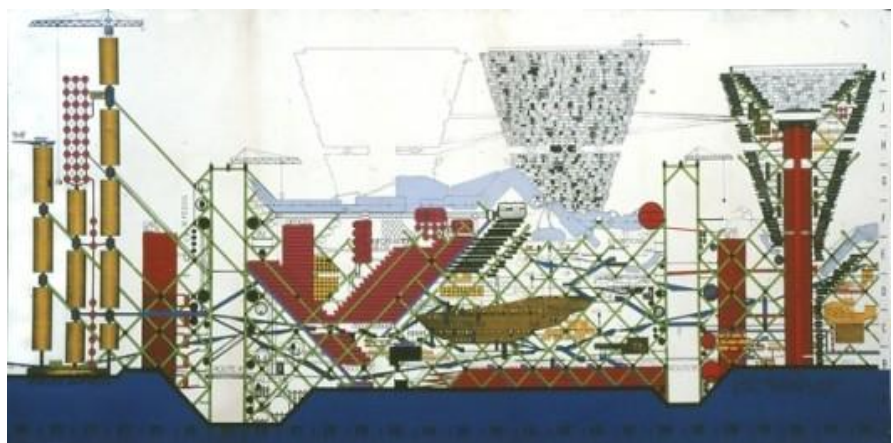

Fig.2.10 - Image of the Archigram's Plug-in City (1964): This provocative project suggests a hypothetical fantasy city, containing modular residential units that "plug in" to a central infrastructural mega machine. The Plug-in City is in fact not a city, but a constantly evolving megastructure that incorporates residences, transportation and other essential services—all movable by giant cranes (source: <http://www.archdaily.com>)

The “formless” designs of the 60's and 70's also reviewed themselves in Contemporary architecture. Groups such as Archigram, Superstudio and Metabolism, gave birth to an utopian architecture based on the fusion between new technologies and architecture. This emphasizes the tendency of architectural practice to exploit and adapt new technological advances. Archigram's projects have introduced new visions and interpretations of what should be the place of technology in the society and culture (see Fig.2.10). Their works constituted games of meaning between mechanics and organics, which then originated utopian projects that broke with the norms of beauty and function of their time.

Throughout the history of architecture, specially up until the later periods of the 19th century, we can see a great presence of round shapes in buildings, but those have since then been diminished and excluded. In present times however, round shapes have been rescued by the new architecture, in great part due to the help of 3D modeling tools. With them the industrial production and manufacturing of smooth curved structures was facilitated and achievable. Complex curvilinear shapes are produced as easily as the traditional geometries and are described mathematically as NURBS curves (Non-Uniform - Rational B-Splines). The attractiveness of these geometries is the ability to easily control their shape, through the manipulation of control points, and also the attainable production of these coherent forms (see Fig.2.13).

The use of parametric surfaces is also rising in the field of Contemporary architecture: the design of parametric shapes has an intent behind it, which dictates the parameters for a sort of design instead of the shape itself. The configuration of parametric design depends on the parameters given values and this design approach adopts an exploitation of infinitely different results, instead of fixed solutions (Kolarevic, 2005).

In addition to these highly complex forms, there is also a tendency for the production of architectural screen walls, which can have linear or complex shapes but with intricate patterns (see Fig.2.15). Screens became a common and rich architectural device that can separate spaces, while maintaining a certain visual. In contrast to glass, screens have a strong presence and offer the possibility to vary their materials, color, texture, etc. They can assume



Fig.2.11 – ICD/TKE Research Pavilion (2011) in Stuttgart University by Achim Menges and J. Knippers (source: www.achimmenges.net/)



Fig.2.12– 3D Spacer Textile Composites by Nico Reinhardt (source: www.achimmenges.net/)

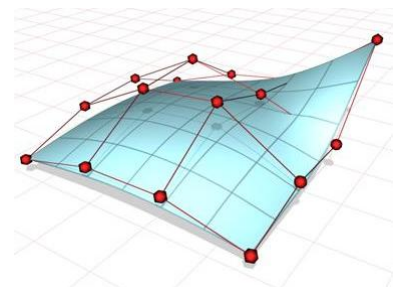

Fig.2.13 - Image of a NURBS surface with its controllable vertices in red (source: www.3dmax-tutorials.com)



Fig.2.14 - Photography of BMW Welt in Munich by Coop Himmelb(l)au (source: www.archithings.com)

other functions such as passive shading on facades (Gramazio & Kohler, 2008).

The existence of screens in architectural practice is not new. As an example, consider the screens in Islamic Religious architecture, which are highly perforated grids with an ornamental value. Nevertheless, with new technologies and means of production, the generation of architectural screens can reach highly complex patterns, using less common materials.

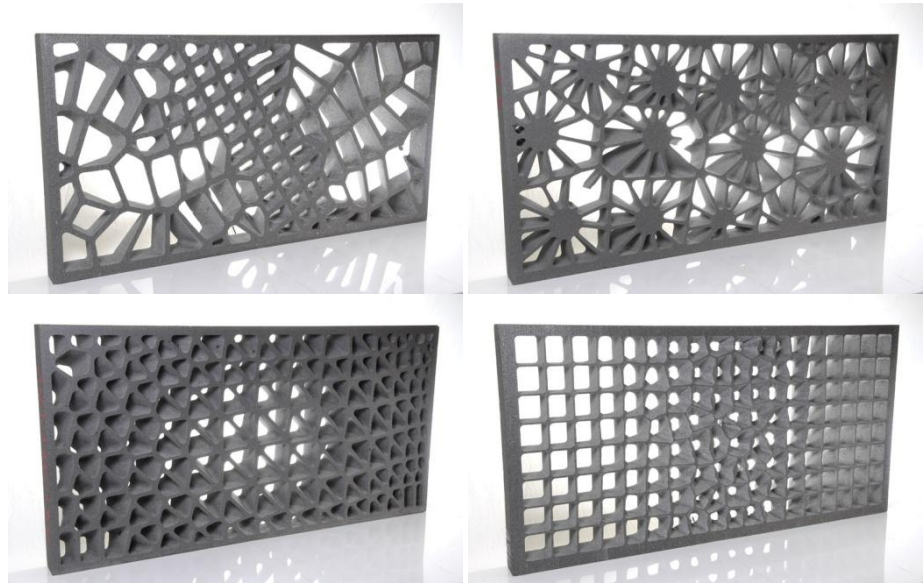

Fig.2.15 – Different screens designed with algorithmic tools, which helped the manipulation of the contours, dimensions, angles and the sequence of openings. The screens were produced with robotic cutting. Designed and produced by Gramazio & Kohler Research (source: <http://gramaziokohler.arch.ethz.ch/>)

2.2.2 PERFORMATIVE ARCHITECTURE

In the 50's, the term *performance* appeared in several disciplines as a concept of great outcome and, consequentially, the understanding of culture as something static evolved into the notion of culture as a network with dynamic processes and interactions, which is the opposite of form and meaning fixity. The increasing interest in performance, in nowadays society's culture, emerged into a performative approach (Kolarevic, 2005), which has also been reflected in the field of architecture.

Architects started to realize that building performance and behavior could be a relevant input in both design and form finding processes (Fasoulaki, 2008) and Performative architecture became another type of design approach emerging nowadays. The interest in performance as a design is not only due to the fresh developments in technology and cultural theory, but also to the

new socio-economic matter of sustainability (Kolarevic, 2005). Performative design evolves from a merely aesthetic approach to an approach towards the behavior of the buildings, wherein the building is modulated by how it performs rather than how it appears (Fasoulaki, 2008). Performative architecture is the change of guidance, in the practice and theory of architecture, from what the building is to what it does and uses the building performance as a guideline for the design, which embraces a recent list of performance-based priorities for the architectural design.

This pursuit for performance requested the exploration for innovative tectonics and "new" materials that were not used in building industry. While previously geometry was forced on the material, currently, geometry can emerge from the material and its structural performance. Performative architecture is using digital technologies to challenge the manner how the building environment is designed and defines the building by its ability to affect and to transform, i.e. by its ability to perform (Albayrak, 2011). The model can perform as a mechanism to generate and modify designs, wherein its formation process is driven by analytical techniques which allow a direct variation of the geometric model. The building's performance can be structural, environmental, economic, ecological, spatial or technological.

This approach to design aims to produce an architecture capable of generating and adapting to new shapes through optimization methods, i.e. problem solving methods that search for the best way to satisfy a need within several constraints using the available means (Fasoulaki, 2008).

"As a paradigm for architecture, performance describes the processes through which culture, technology and architecture become interrelated to form a complex field of relations which produce new and powerful effects. Instead of describing the architectural object, performative architecture focuses on how the architectural object performs by producing new effects that transform culture" — (Albayrak, 2011)

2.2.2.1 Performative Architecture as Performance-Based Design

The definitions of Performative architecture are numerous and, when analyzing the literature about this topic and the respective description of performative architecture, it is possible to separate the ideas in two

divergent main perspectives (Oxman, 2006). The first perspective relates performative architecture with concepts like self-support and energy-saving. It understands performative architecture as a technical issue and seeks technical developments in manufacturing processes, such as structural, thermal and acoustical. As Oxman said "...Formation-based design can be regarded as performance-based design when digital simulations of external forces are applied in driving a formation process. Design performance may include among the following parameters: environmental performance, financial cost, spatial, culture, ecological and technological perspectives. Performance-based design employs analytical simulation techniques that produce detailed parametric expressions of performance" (Oxman, 2006).



Fig.2.16 - Photography of the City Hall in London, designed by Foster+Partners (source: <http://www.fosterandpartners.com>)

The City Hall is one of London's new projects, which was designed by Foster and Partners (Fig.2.16). This building is a good example of this first perspective of Performative architecture, since it manifests the potential of a whole sustainable, virtually non-polluting public building. The design approach was developed by environmental performances with respect to light, heat, energy, movement and sound. In fact, the final design solution was radically changed from the initial idea, and the shape of the final project was the result of a process of energy performance optimization: the surface exposed to direct sunlight was minimized, being that there was a reduction in solar heat gain and loss through the building's skin (Whitehead, 2003). The analysis of the acoustics also influenced the final shape of this building: The reflection and absorption of sound by surfaces was visualized by a process developed by Arup and, only when the building's shape became acoustically

acceptable, was the solution considered viable. In the end, the final shape of the City Hall derived from performance evaluation using various criteria that allowed the building mechanical systems to consume fifty percent less energy than a typical office building (Whitehead, 2003).

2.2.2.2 Performative Design as an Architecture of Performance

The second perspective defines Performative Architecture as "the marriage of virtual reality capable of accurately simulating physical experience, and physical reality capable of a total incorporation of cyberspace" (Hagan, 2008). In addition, it includes new territories of architecture, such as response, movement and evolution, defending that the building should be designed in such way that it is able not only to interact with people, site, climate and time, but also to change according to the interaction (Hagan, 2008). This second perspective embraces the concept of Architecture as performance, i.e. an architecture that makes a performance in the city (Kolarevic, 2005), and includes performance models, simulation techniques and optimization algorithms (Fasoulaki, 2008). Usually, it is the building's skin that contains the complex morphology and tectonics, i.e. the performative effect. The work developed in this thesis is closer to this second perspective, since it was inspired by what it is most visible in the practice of architecture.



Fig.2.17 - Photography of the Kunsthhaus dynamic display surface of lights in Graz, Austria (source: www.aracnob.blogspot.pt)

The museum building Kunsthhaus Graz of Peter Cook and Colin Fournier, shown in the Fig.2.17, can be included in this second perspective of Performative architecture. The building has an irregular or biomorphic shape and is enveloped by a dynamic display surface of lights that change their pattern over time. Each light acts as a pixel and its brightness can be

controlled by a computer and infinitely varied at the rate of 18 frames per second. This allows the generation of light patterns over the entire facade and be visible from a considerable distance all over the city (Edler, 2005).

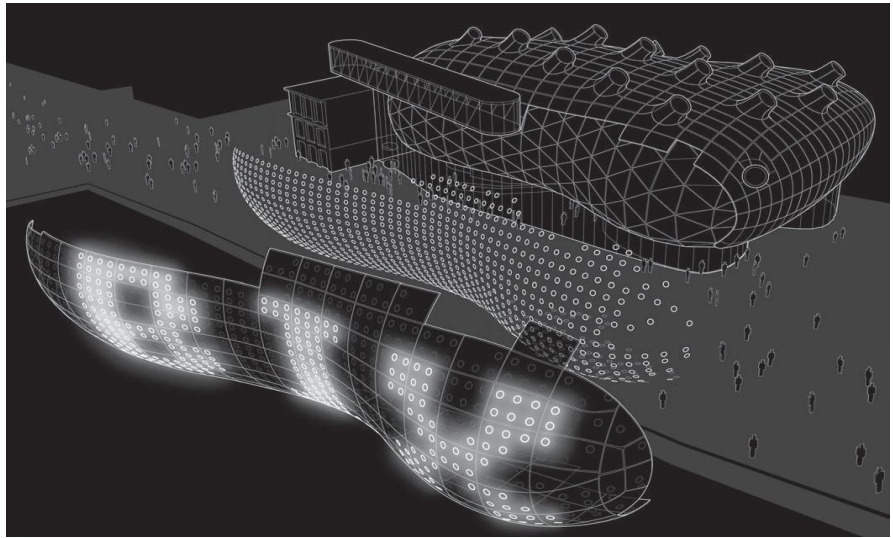

Fig.2.18 – An exploded view of the lights matrix as a part of the Kunsthaus facade (source: (Edler, 2005))

In fact, the building's facade is a performative display skin acting as an alterable membrane, which transmits the internal processes of art institution to the outside public (see Fig.2.18). The facade of Kunsthaus Graz combines architecture and media installation to generate a new aesthetic result, where it was transformed into a low resolution computer display, which incorporates together architecture, technology and information (Albayrak, 2011).

The concept of Movement as performance can be considered as a sub-class of this second perspective of architecture as performance. The movement of people around and inside a building gives the performative capacity to architecture and, recently, performativity is also present in the architecture's kinetic effects, which creates an architecture of spectacle and performance (Albayrak, 2011).

2.2.2.3 Architecture as Both Performance and Performance-Based Design

In addition to these two perspectives we can also consider a third perspective that combines the two previous perspectives. There is also a part of performative architecture that joins the concept of energy consumption optimization with the concept of architecture as performance. Architecture has always sought an aesthetic balance, so the goal of reducing the energy

cost can influence the design in order to create, simultaneously, an attractive architecture.



Fig.2.19 - Photography of Southern Cross Station in Melbourne, Australia (source: <http://openbuildings.com>)

The Southern Cross Railway Station in Melbourne (2002) is an example of this third perspective (Fig.2.19). The railway station indisputably needed some roof performance requirements. Indeed, the roof not only acts as an umbrella or sunshade, but also as an extractor of stale air from the diesel trains. However, there was also the necessity of the building to be visually interesting, because of the surroundings and the number of buildings that look down on it. The problem of removing the stale air from inside the station could have been solved with the employment of great exhaust fans but such solution would not be sustainable nor esthetically pleasing. Instead, by observing the phenomena behind the formation of sand dunes and snow moguls, the architects were able to conclude that they could model the roof in a similar shape, so that the local prevailing winds would cause changes in air pressure. The creation of negative pressures along these roof "dunes" would force the air inside the station out. This means that the roof functions effectively and, at the same time, it is also visually interesting. This project is an example of an architecture whose performance criteria gives both shape and form and aesthetical qualities (Whalley, 2005).

2.2.3 KINETIC OR ADAPTIVE ARCHITECTURE



Fig.2.20 – An example of Kinetic architecture of the past: Drawbridge at the fort of Ponta da Bandeira in Lagos, Portugal (source: <http://en.wikipedia.org/wiki/Drawbridge>)

Contemporary architecture often makes use of digital media as a generative tool for the derivation of forms and their transformations; a process known as “digital morphogenesis”. The digitally-generated forms are calculated by generative processes based on concepts such as topological space, isomorphic poly-surfaces, i.e. blobs, motion kinematics and dynamics, key-shape animation, parametric design, genetic algorithms and performance simulation (Kolarevic, 2005). Some of the processes used in this “digital morphogenesis” are respectively Adaptive and Kinetic architecture, which are two types of architecture, while “digital morphogenesis” is a design process. Adaptive and Kinetic architecture are the means to an end to produce architecture that adapts to the local conditions.

Adaptive Architecture is a type of architecture that is concerned with buildings that are designed to adapt to the demands of their environmental conditions. This adaptation can be automatic or also can be through human intervention (Schnädelbach, 2010). This type of architecture is related with the optimization of energy spending, and this optimization is made through physical adaptation. This adaptation includes, not only chemical modifications of certain materials, but also the moving of some of the building parts (see Fig.2.20). The most common example of Kinetic architecture is the use of shutters on the buildings' windows.

Kinetic architecture is a type of architecture that includes the concept “movement as performance”, while approaching the concept of Adaptive architecture. However, not all Kinetic architecture can be included in Adaptive architecture. Kinetic architecture allows parts of the building's structure to move, without decreasing the overall structure integrity. This skill for motion can be used, not only to improve the building's aesthetic qualities, respond to environmental conditions, but also to add functions that would not be possible in a static structure. This type of architecture existed already in the past, but since the end of the 20th century its presence has increased due to the evolution in the fields of mechanics, robotics and electronics, which, consequentially, promoted more possibilities for the practical implementations of this architecture. Within Kinetic architecture, only the buildings that use movement to adapt to external conditions in order to optimize the energetic costs, can also be classified as Adaptive

architecture. The following example can be classified as both kinetic and adaptive architecture.

2.2.3.1 INSTITUT DU MONDE ARABE

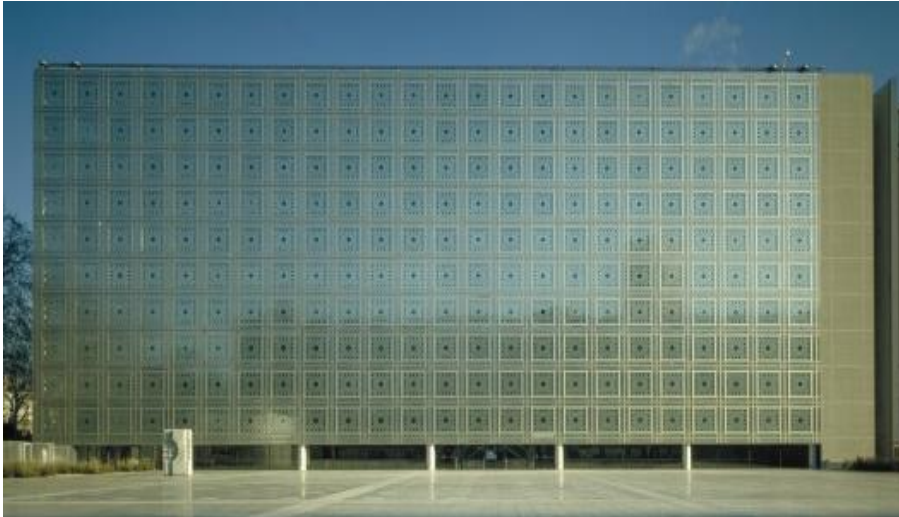

Fig.2.21 - Photography of the Institut du Monde Arabe in Paris, France (1981–1987) (source: <http://www.archdaily.com/>)

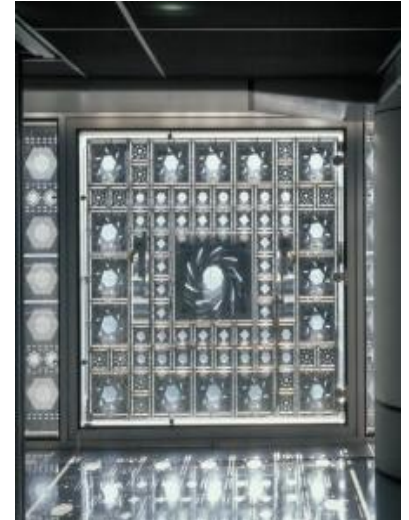

Fig.2.22 - The kinetic Mashrabiya (source: www.archdaily.com/)

Located in the centre of Paris, the *Institut du Monde Arabe* was conceived to be an architectural landmark of the city (Fig.2.21). It was designed by Jean Nouvel and constructed in 1987. Jean Nouvel used Mashrabiya units, a type of a window cover consisting in combining backdrops of cut wood and latticework patterns, as a symbol of the Arabic culture (Fig.2.22). In fact, Jean Nouvel combined this Arabic pattern with the need for sun shading and the idea of light control in the diaphragm of a camera lens. This originated a modern high-tech building with a pierced facade that simultaneously makes reference to the symbols of Arabic culture (Heylighen & Martin, 2004).

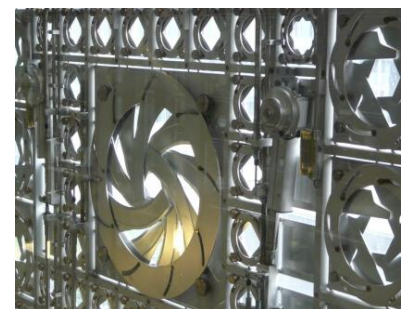

Fig.2.23 - The diaphragms of the Mashrabiya units (source: www.archdaily.com/)

The regular southern facade is made of 240 square panels that reproduce the overall pattern and are constituted by a thousand kinetic modules with several shapes, such as lozenges, squares, hexagons, etc. Each kinetic panel is made up of a central large diaphragm surrounded by several medium and small diaphragms (see Fig.2.23). The mashrabiya units are used as camera lenses intrinsic to the building's Mashrabiya units pattern (Fouad, 2012). The building's facade consists of high-tech photosensitive mechanical devices that control the light levels and transparency, operating like a lens of a camera. All mashrabiya diaphragms are linked together and controlled by photo-voltaic cells that are in charge of closing or opening them depending on the sunlight's intensity (Fouad, 2012). The facade of this project is an

example of Adaptive Architecture, because the surface responds to the changing environmental conditions in order to optimize energy.

2.2.3.2 NEW ESKENAZI HOSPITAL PARKING STRUCTURE



Fig.2.24 - Photography of the New Eskenazi Hospital Parking Structure by Urbana Architects (source: www.arch2o.com)

The example in Fig.2.24 shows the transformation work of a traditional parking structure, which becomes similar to a kinetic approach. Urbana Architects were in charge of a project to transform the old Eskenazi Hospital Parking and they decided to integrate a dynamic facade as a final outcome of the initial intention to camouflage the parking structure, thus creating a quite interactive element for the city. This kinetic approach for the facade was built static, which seems to contradict the origin of the term Kinetics. Nevertheless, the design approach takes into consideration the fact that, in the park's surrounding area, the viewers would themselves be moving in different directions, thus giving the sense of kinetics to the facade. The project uses thousands of angled metal panels in combination with an articulated east/west color strategy, which creates a dynamic facade system that offers the viewers unique visual experiences according to their point of view and the place where they are moving to (Arch2o, 2014). The image below shows the variety of patterns produced by the facade according to viewers point of view.

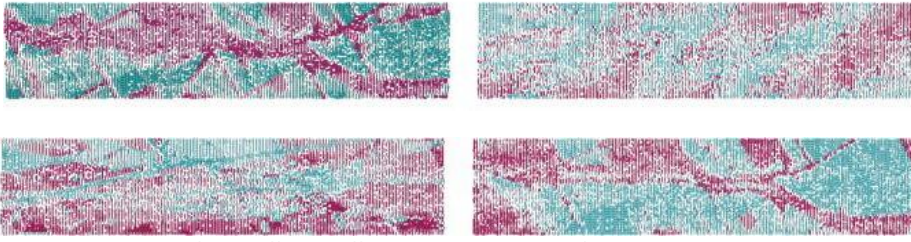

Fig.2.25 - Some of the different effects produced by the facade depending on the viewers place of view. (source: www.arch2o.com)

2.2.4 PARAMETRIC ARCHITECTURE

The term parametric has its origins in the Greek word *Para-metron*, which means parameters and it was in Mathematics that parameters began to have its practical application. The term Parametric arises from the parametric equation, with its use related to the application of certain variables that could be edited to control or alter the end result of a equation.

Unimaginably, the term parametric had already had its expression in architecture since Ancient Egypt, where the design and construction was done in relationship with several changing forces, including not only climate, use, character, as well as technology and culture. In addition, nature and its natural processes, more precisely the growth of the organic shapes, influenced the mathematics' imagination, which in turn tried to approach nature using parametric processes. This knowledge influenced many architects in the design of both biological shapes and patterns, however it was very difficult to draw with detail the evolving forms and complex patterns of organic life (see Fig.2.26, Fig.2.27 and Fig.2.29).

In the beginnings of the 90's, the computer evolved as a tool capable of simulating the generation of biological forms (morphogenesis) which could then be analyzed and reconstructed using parametric models. It was not through the computer that parametric design was created, however, it had been enabling architects to design and also construct innovative buildings with more precise qualitative and quantitative conditions (Sumi, 2013).



Fig.2.26 - Rendered view of the Engineering Research Institute at Minho University in Guimarães, by Cláudio Vilarinho Architects (source: www.claudiovilarinho.com). The building's skin was inspired by the microscopic image of titanium nanotubes.



Fig.2.27 - Photography of Airspace Tokyo by Faulders Studio, in 2007 (source: www.arch20.com) The building's skin manifests organicity, thus resembling a neurological system.

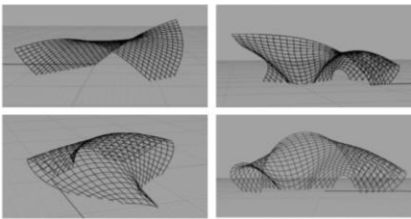

Fig.2.28 - Image of a Parametric Form Finding technique (source: <http://designontopic.files.wordpress.com>)



Fig.2.29 - The "Bubble" BMW pavilion in Frankfurt, Germany. Its form inspiration was based on two drops of water joined together. The pavilion was designed by Bernhard Franken, in 1999 (source: <http://www.itaproject.eu/>)

Parametric Architecture is a design approach based on algorithmic thinking, which allows the expression of parameters and rules that encode and define the relationship between the design intent and design response (Jabi, 2013). The constituent geometry is mutually linked (Burry, 1999) creating an associative geometry, which is defined by equations that describe the relationships between the design elements. In fact, "parametrics can provide a powerful conception of architectural form by describing a range of possibilities, replacing in the process stable with variable, singularity with multiplicity" (Kolarevic, 2005). Through Parametric design, architects design a set of principles encoded as a sequence of parametric equations, which then generates and also changes the model's design when needed (Fig.2.28). With this, we are facing an architectural design approach that sets aside stable solutions and follows an exploration of infinite possibilities.

Architecture's activity has followed both evolution of Man's needs and technical developments. In fact, Man constructed what he was able to build. New techniques and discoveries of new materials has allowed architecture to evolve progressively until our days. This architectural evolution began to reach its peak in the 50's with the birth of computers. This was the beginning of a tremendous renewal in the field of Architecture in two perspectives, where one is the design approach, creation, change and evaluation by the architect, and the other is the way of construction of these new designs (Fernandes, 2013). This was achieved by the use of CAD and CAD/CAM technologies that can assist the design process from the early stages until the phase of construction. Yet, in comparison with other fields like the airplane and ship building industry, architecture has been slow in adopting these new technologies in order to take advantage from them.

3.1 GENERATIVE DESIGN

"Generative Design is the transformation of computational energy into creative exploration energy empowering human designers to explore greater number of design possibilities within modifiable constrains"

— (Krish, 2013)

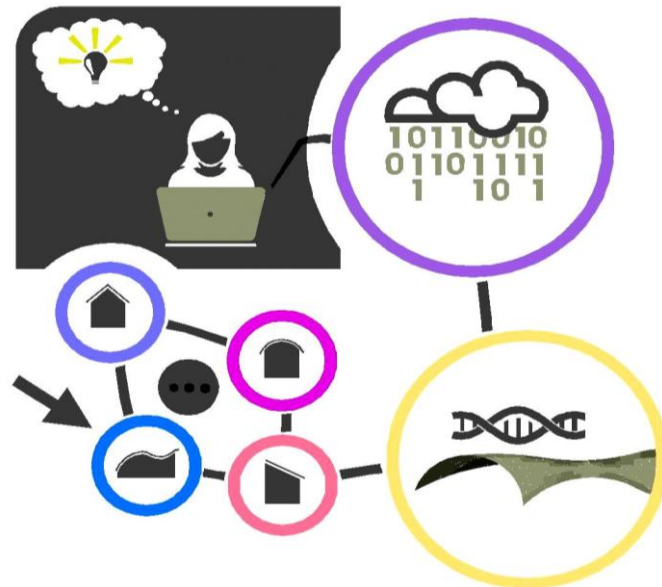

Fig.3.1 - Synthetic Scheme of Generative Design.

Design is an evolutionary process (Alfaris, 2009) from the initial and conceptual idea to complex and concrete results. Generative Design (GD) is a design process where the output is generated with the help of a computer and through the use of algorithms (Terzidis, 2003). Through the use of Generative Design architects design the system that originates the building, instead of designing the building (Stocking, 2009). It enables the generation of several solutions in a short period of time, avoiding the tedious and repetitive tasks needed when the modeling work is done manually, even with state-of-the-art CAD/BIM (Computer Aided Design/Building Information Modeling) software. With this control of change, the designer can quickly compare and evaluate multiple solutions, which helps him to make a more informed choice. In addition, GD enables and facilitates the manufacturing of complex solutions, by extracting documentation directly from the model to the phase of CAM (Computer Aided Manufacturing) or Digital Fabrication. Generative design is used in the production of digital ornament and complex facades, seen in many contemporary buildings, however, in order to take advantage of the computational power of computers, algorithms must be implemented in programming languages (Leitão, 2014). To use this new

approach, architects need to know how to use programming languages, an initial investment which will be rewarded later during the experimentation phase.

The use of algorithmic systems is the base of the foundation of most Generative Systems. The definition of Algorithm can be described as a set of rules that precisely defines a sequence of operations necessary to perform some task. So, with the crucial help of modern computers, these operations are interpreted and performed through computation, thus allowing the experimentation of multiple design solutions.

In the late 20th century the development of architectural software began to evolve, thus allowing Generative Systems to gain consistency. This evolving technology inspired many authors and architects at the time, who have seen the emerging possibilities. Already in Greg Lynn's *Architectural Curvilinearity* (1993), he exposed one of the first topological approaches to design, wherein instead of using Euclidean geometry, he used parametric functions to represent highly curvilinear surfaces, or NURBS, in order to describe a range of solutions. Peter Eisenman also recognized in one of his works (*Koder*, 1994) not only the power of using algorithms to produce results that the architect would not know previously, but also that writing and adjusting algorithms would become one of the tasks of the design process. In fact, instead of going directly from idea to design, design limitations can be addressed by an intermediate step based on an algorithmic description of a design, implementable in modern programming languages (Leitão, 2013). The barrier between the designer's idea and the materialization of that idea was overcome, wherein this contemporary architecture is defined by complex forms and patterns. Then, with the emergence of new programming languages, Generative Systems finally began to be used in the architectural field.

Generative Design enabled not only the generation of complex forms and their fabrication with fair budgets, but also the continuous exploration of a design, generating many versions, quickly and effortlessly (Fernandes, 2013). This means that "the processes of describing and constructing a design can now be more direct and more complex because the information can be extracted, exchanged, and utilized with far greater facility and speed. In

short, with the use of digital technologies, the design information is the construction information" (Kolarevic, 2003).

3.2 GENERATIVE SYSTEMS

The basic system of most Generative systems is the Algorithmic system. Their definition is sequences of instructions for solving a certain problem or reaching some end, that are written in a fixed vocabulary detailed step-by-step or in distinct steps. In computers, algorithms are fundamental to the way computers process information, in which they can handle numbers, alphabets and geometric entities. Algorithmic systems used for design need clear design intentions expressed in its steps and units, but their use is still good for creating complex geometries with small amounts of data, such as locations, shapes, shape properties, etc. The communication between the elements is made through rules, constraints and associations (Fernandes, 2013). The use of algorithms in design requests a rationalization process that forces designers to organize and coordinate their thinking around relations and sequences of tasks. However, as Algorithmic Systems do not constrain the relationship or structure, they are the most customizable and flexible of all Generative Systems.

Another kind of Generative system are Shape Grammars (SG), a formalism published for the first time in a paper written by Stiny and Gips in 1972. Shape grammars can be very briefly defined as the combination of a vocabulary of shapes, plus a set of shape rules and an initial shape (see Fig.3.3). The goal of the rules is to transform a shape, or a collection of shapes, into a new shape (Chouchoulas & Day, 2007). So, in computation, shape grammars are a type of production systems that produce shapes. During the first decades, Shape Grammars had applications focused mainly on analysis, however SGs can have two other purposes, such as synthesis and the combination of synthesis and analysis. The use for analysis is to identify some existing design languages in order to produce multiple solutions belonging to the same language. The use for synthesis is to create original designs, i.e. new design languages (Fernandes, 2013).

One of the first applications of SGs was on Palladian designs, thus resulting the Palladian grammar. This was a starting point that initiated more complex Shape Grammars for architecture that continues today (Knight, 1999). Although the implementation of Shape Grammars' interpreters in computers has been a difficult task, due to the duality between visual and symbolic computations, SGs are a good method to help architects in the understanding of styles and in the expression of their design intentions.

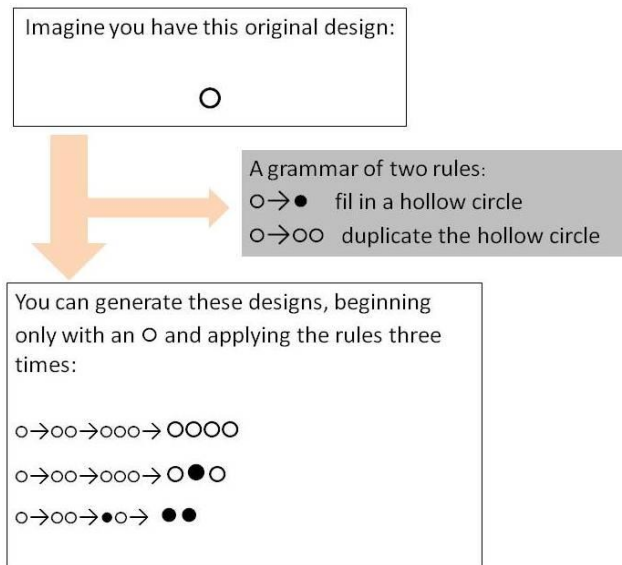

Fig.3.3 - An example of a shape grammar. (source: www.andrew.li)

A Genetic Algorithm (GA) is another Generative System, that belong to the larger class of evolutionary algorithms. In architecture, GAs can be used not only as optimization tools, but also as form-generation tools, by using techniques inspired by natural evolution, such as mutation, selection, crossover and inheritance (Fig.3.2). Genetic Algorithms can be described as a heuristic search that imitates the process of natural selection to generate useful solution for the optimization and search problems (Mitchell, 1996). They can perform the same operations that nature applies on populations, of which only the strongest solutions and the solutions that fit better will survive. The selection is performed based on a fitness function that determines how "good" the solution is, and it is applied to each generation produced (Fasoulaki, 2007). The "genes" that constitute the strongest solutions are used to generate the next generation, where they are crossed over to create new solutions, wherein simultaneously some variations are introduced to these new solutions by mutating some genes. In the end of this evolution, where each generation has a better combination of solutions

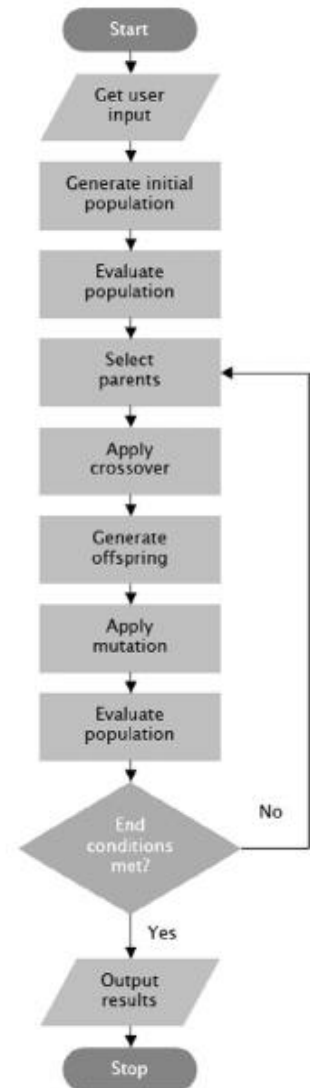

Fig.3.2 - An example of the process of Genetic Algorithms (source: (Chouchoulas & Day, 2007))

than the previous one, the final solution is analysed to check if the end conditions meet the required conditions and, if so, the best solution is achieved.

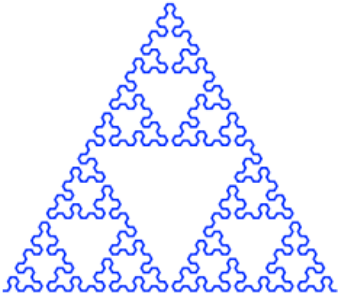

Fig.3.4 - Sierpinski Lsystem (source: Wikipedia)

There are also more specialized versions of Algorithmic Systems, such as L-systems and Cellular Automata. L-systems are alphabets of symbols that can be used to make strings, a collection of production rules, an initial axiom string from which to begin construction, and a mechanism for translating the generated strings into geometric structures (see Fig.3.4). They are used to model both the morphology and the growth process of a variety of organisms, and also to generate self-similar fractals, i.e. repeating patterns that display at every scale (Rozenberg & Salomaa, 1980). Cellular Automata were originally conceived by Ulam and von Neumann in the 40's, to originate a formal framework for investigating the behaviour of complex and extended systems. It consists of a regular grid of cells, where each cell is placed in one of a finite number of states. The cells modify their state according to update interaction rules, applied simultaneously to all cells of a grid in discrete time steps. The state of a cell is determined by the previous states of a surrounding neighbourhood of cells (Bentley, 2010). Although the use of Cellular Automata in areas such as mathematics and engineering has had applicability, in architecture its application is very restricted because it is very unpredictable due to its chaotic and random behaviours. The Fig.3.5 shows one of the most famous cellular automata, the Conway's game of life, which was invented by the British mathematician John Horton Conway in 1970.

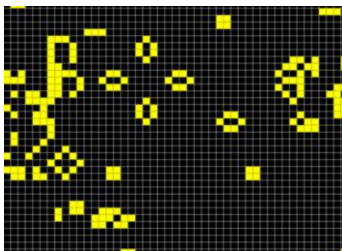

Fig.3.5 - Cellular automata from the Game of Life, 1970 (source: www.joshiscorner.com)

3.3 PARAMETRIC SYSTEMS

"Parametric modelling introduces fundamental change: 'marks', that is, parts of the design, relate and change together in a coordinated way"

— (Woodbury, 2010)

Parametric systems are also a generative system, and can be classified as a special case of algorithmic systems. Parametric design can be defined as the description of a design using variables and parameters, instead of using shapes. These variables are hierarchical and they are controlled by one-direction relationships. In parametric design some parts of the design are independent while others are dependent, and both are connected by dependencies. Thus the spread of changes is produced by these dependencies that go from independent to dependent parts. Nowadays with the use of parametric design in architecture, architects started to design, instead of shapes, a combination of principles encoded as a succession of parametric equations. The advantage of using equations in the design process is that the designer can generate and also vary instances of the design at any time and as he wishes. The approach of parametric design in architecture is profoundly changing not only the entire nature and the established hierarchies of the building industry, but also the role of the architect (Kolarevic, 2003).

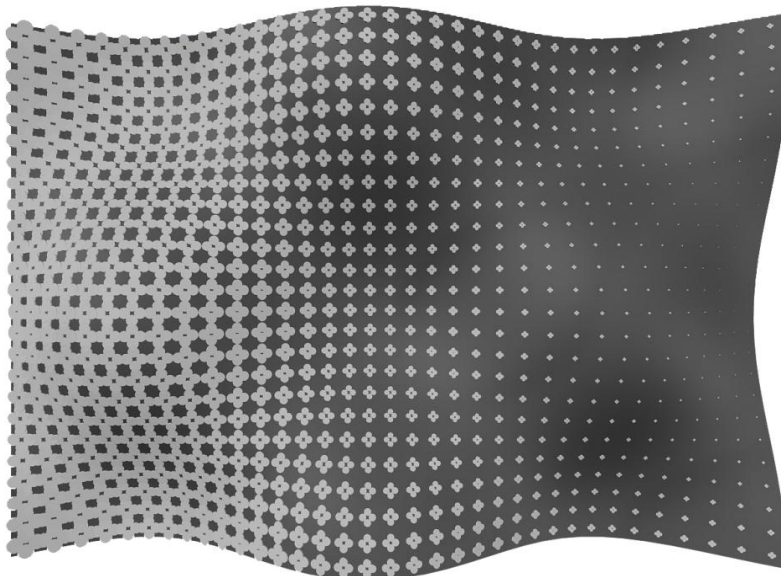

Fig.3.6 - An example of a parametric surface.

3.3.1 HISTORY OF PARAMETRIC TOOLS

Nowadays designers not only use the computer to build models but also to visualize ideas, being that it is important to understand how the computer is a tool for both simulation and fabrication and not simply for representation. Traditional models are limited because they are very difficult to modify interactively, as changing one part in a complex model might require extensive low level modifications. To get over this limitation, designers began to use parametric design tools (Jabi, 2013).

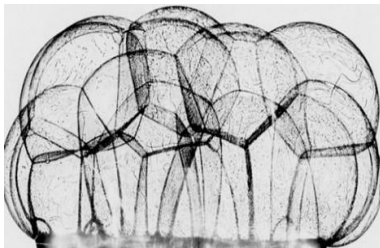

Fig.3.7 - Frei Otto's form finding technique, foam bubbles (source: www.plataformadeartecontemporaneo.com/pac/lightness-en-el-mua/)

This idea of parametric is not new: it already has a long history in mathematics, where the earliest examples of parametric used to describe 3D models comes almost in the middle of the 19th century. Already in 1837 with James Dana's parametric crystal drawings, he explained the steps for designing a range of crystals and possible variations, using a language encoded with parameters, variables and ratios. Yet, only almost 170 years later, this process of equations were then used by architects to develop parametric models of buildings.

The use of the basic concept of parametric design was also present in some of Antonio Gaudi's works in the turn of the 20th century, such as the forms of Colonia Guell which were derived using a hanging chain model. At the beginning of 1950's, also Frei Otto applied unconscious parametrical thinking in his works when he used physical parametric models as a form finding technique (Davis, 2013).



Fig.3.8 - Ivan Sutherland's Sketchpad console, 1962. Sketchpad is operated with a light pen and a command button box (under left hand). The four black knobs below the screen control position and scale of the picture (source: www.mprove.de)

Still, the initial use of the parametric term by designers was in the 1940s with the extensive writings of the architect Luigi Moretti about "parametric Architecture". He defined parametric design as the study of architecture systems in order to define the relationships between the dimensions dependent upon the various parameters. In 1957, Patrik j. Hanratty created PRONTO, the first commercial software to conceive parametric algorithms for passing data from computers to manufacturing machines. Then in 1963, Ivan Sutherland developed Sketchpad (Fig.3.8), the first parametric software, and for the first time, the graphical representation of parametrics was demonstrated. Two decades later, Parametric Technology Corporation

produced the first commercially successful parametric modelling software in 1988, Pro/Engineer (see Fig.3.9).

Parametric modelling software finally became viable with the commercialization of Pro/Engineer, however only a decade later was it designed specifically for architects. Initially parametric design software was developed principally for Engineers and for the transport industry. They needed to use products that enabled the whole to be resolved into associated and adaptable parts (Burry & Murray, 1997). Every time a design changed, regardless of the size of change, the design needed to be redrawn. With parametric systems emerged the possibility to simply regenerate the designs, instead of redrawing or editing. Another reason for the introduction of parametric modelling was the desire to decrease the cost of change. As Geisberg, the founder of Parametric Technology Corporation, said "the goal is to create a system that would be flexible enough to encourage the engineer to easily consider a variety of designs. And the cost of making design changes ought to be as close to zero as possible. In addition, the traditional CAD/CAM software of that time unrealistically restricted low-cost changes to only the very front end of the design-engineering process". He defined this capacity of parametric models to easily change as flexibility, which enabled the designers to make changes (Davis, 2013).

3.3.2 PARAMETRIC TOOLS: FINDING A MEANING

Parametric Models pose a challenge to expand the design process beyond current limitations of traditional CAD Systems. Firstly, because they produce a high fidelity representation due to the specification of the relationships between parameters with algorithmic thinking. Secondly, by offering more flexibility to design parts and assemblies of complex nature. Thirdly, by providing a reliable system to test instances of the design from a single model, and lastly by expanding the design exploration at the initial stages of the process (Barrios, 2005). Summarily, a parametric model is aware of the characteristics of components and the interactions between them, maintaining consistent relationships between the elements as the model is manipulated.

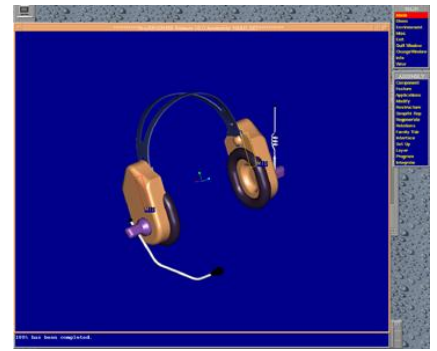

Fig.3.9 - Pro/Engineer in 1988 (source: www.deskeng.com)

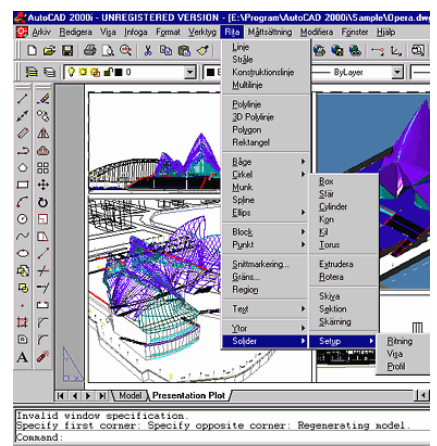

Fig.3.10 - AutoCAD 2000 environment (source: www.eurocitysoftware.com/)

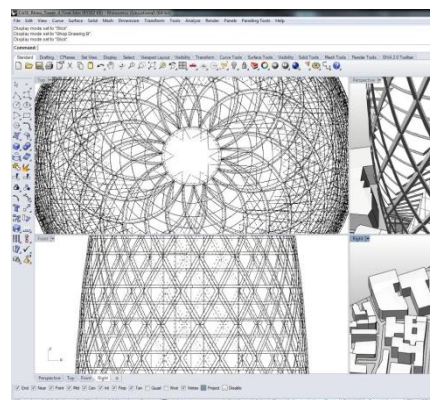

Fig.3.11 - Rhino5 environment (source: <http://3.bp.blogspot.com/>)

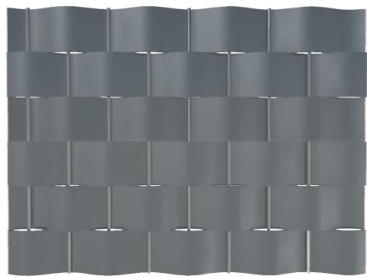
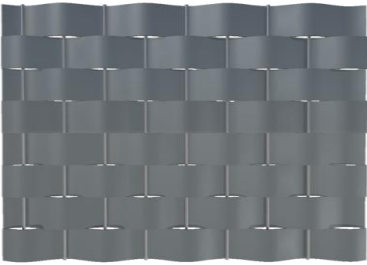
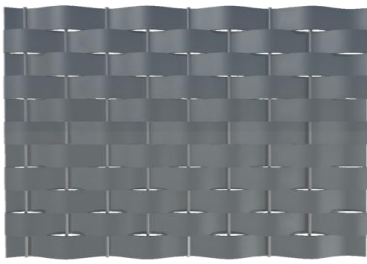

Fig.3.12 - Parametric Variations: The number of stripes in each model varies between 6 and 11 stripes.

For some authors, a Parametric Model can be defined as a set of equations or rules configured by a series of parameters or variables that expresses a geometric model. Here the associative nature of these parametric systems enables the generation of geometric relationships between objects (Watts, 2007). A parametric model is unique, not because it has parameters, neither because it changes, but because of the way it was created. It is an abstract representation of a system in which some elements have attributes that are fixed and others that can vary. Through parameterization, it is defined which components of the model will vary, the variables, and how this variation occurs. Variables can be independent or dependent and this is when its value is relayed to the value of another entity of the model. Thus, Parametric modelling can also be described as the process of making a geometrical representation of a design with components and attributes that have been parameterized (Barrios, 2005).

This kind of systems have the advantage of creating design representations that admit rapid change of both design dimensions and structure, i.e. designers can use the same structure to rapidly explore better design alternatives (Woodbury, et al., 2011). Parametric models can be flexible enough to be constantly evaluated, revised and updated within the same structure if different components are added, changed or deleted. This allows a level of flexibility to perform transformations that result in different configurations of the same geometrical components without erasing or redrawing.

Understanding why architects choose to use parametric models, a seemingly counterintuitive medium for creativity and exploration, is a crucial step towards realizing the challenges associated with parametrical modelling. In addition to their capacity to explore several design iterations in the digital realm, before ever realizing them in the physical landscape, a great advantage of using these models as components to the manufacturing pipeline is allowing users to control the production of documentation and the precision indispensable to the manufacture (Anderson & Tang, 2011).

In the architectural domain, the parametric software commercially available promoted the emergence of other ways to define Parametric Models (PM). One is a PM which is programmed by a specific textual programming

language (TPL), and the other is a PM generated by algorithms that were represented by diagrams or graphs created by visual programming languages (VPL). These visual languages have a greater initial power of attraction than the textual programming languages, due to them requiring a lower level of abstraction. Still, its use turns out to be more limited, since we are limited to the pre-defined scripts and modules, which we cannot change. As a consequence, we may be working with tools that may not suit our goal. On the other hand, when we use TPLs, we construct our own tools, which we can change and adapt according to our necessities. Therefore, TPLs are more abstract than VPLs, but more powerful.

Parametric scripting is a way to generate architectural artefacts that can be realized in the physical landscape through various techniques, such as digital fabrication and industrial manufacturing, by defining, in addition to the design, the documentation needed for fabrication too. The implications that script has on the construction process is something to take into great account. As Woodbury said, although initially the use of programming languages in parametric design is more hard-working, the long practice in using programming languages and in teaching parametric systems shows that designers will often need or will want to write algorithms to generate their own particular ideas. Indeed, nowadays it is easy to produce artefacts that were typically considered too complex, costly and time consuming (Anderson & Tang, 2011).

4 GENERATIVE DESIGN: ARCHITECTURAL PRACTICE

Digital technologies have had a large impact on architectural practice and, thus, new skills are needed in the offices. Generative Design is extending the role of the architect to also become a programmer, thus requiring not only algorithmic, mathematical and abstract thinking as also programming skills. Although many architects may become familiarized with algorithmic and mathematical thinking, programming is a specialized technical skill and the ability to program is still limited to a small group of architects and design teams (Santos, et al., 2012). A consultancy group is the most common model for putting specialized skills into practice and is adopted by both architectural and engineering offices (Hudson, 2010).

4.1 GENERATIVE DESIGN STRATEGIES

Mark Burry is an example of an independent consultant that has been working on the construction of the unfinished design of Sagrada Familia, in Barcelona (Fig.4.1). The work involves using parametric tools to capture the working methods of Antonio Gaudi (Hudson, 2010). It involves translating from physical models, photographs and sketches using known geometric techniques to construct parametric models (Burry, 2003). The model is then used to produce information to drive CNC's machines for fabrication.



Fig.4.1 - A photography of the interior of Sagrada Familia in Barcelona (source: <http://archinect.com/>)



Fig.4.2 - Smithsonian Institution by Foster + Partners in Washington DC, USA 2007 (source: <http://www.fosterandpartners.com/projects/>)



Fig.4.3 - City Hall or Greater London Authority by Foster+Partners (source: www.fosterandpartners.com)

Specialist Modeling Group (SMG) is an internal research and design consultancy group within **Foster + Partners** (FP), established in 1998 and led by Hugh Whitehead. Its group members work with project teams and are involved from concept design to fabrication. They have expertise in complex geometry, environmental simulation, parametric design, computer programming and rapid prototyping (Peters, 2007). Their work is not concerned with the proposing form but with the search for ways of describing these forms. The Smithsonian Courtyard was developed by FP and the development of the model is described as algorithmic (Peters, 2007). The algorithms used are based on an interpretation or translation of a rule set used and described by the design team to the parametric model builder. In this project initial ideas were investigated using more traditional CAD tools and later were captured as algorithms (Peters, 2007). This project's design uses the principle of a design surface, i.e. a NURBS surface, which is defined by a minimal control polygon (Peters, 2007). The surface can be changed by vertically moving the nodes of this polygon and, in combination with a structural grid this design surface controls all further construction geometry.

The Greater London Authority or the City Hall is another Foster and Partner's project that was designed with a similar algorithmic approach. The building began as a free-form surface with a demand for using a planar mesh solution to meet the budget and architectural criteria. The project was parameterized as a family of sheared cones, which is a an arc-based method that gives a planar quadrilateral panel solution.

The **BlackBox** group is one of the teams that works with **Skidmore, Owings & Merrill** (SOM), which defend that computers have supplanted most of the manual traditions of practice. Their methods are guided by the performance of the building for form-making but also for the exploration of the power of computation as a creative design tool with ongoing research into parametric relationships. The focus of SOM's BlackBox is to make tools to improve the preliminary design process using skills in parametric modeling, geometry, scripting and analysis software (Fernandes, 2013).

Buro Happold (BH) operates two groups in the UK: Software Modeling Analysis and Research Technology (SMART) and the Generative Geometry Group. Both provide parametric and generative support to other project design teams. The SMART group consists of a team of engineers and programmers who take logic from architects and capture design ideas as computer code. As they are based in an engineering practice, a key task is the production of data files for structural analysis and structural geometry for contractors. In addition, they create their own software as plug-ins to Rhinoceros Software which gradually get extended as the need arises (Hudson, 2010).

It is also possible to highlight ARUP's **Advanced Geometry Unit** (AGU) as an example of a multidisciplinary team that mixes architects, engineers and computer scientists, with mathematics, physics and programming skills. The group's primary concern is to find solutions to problems proposed by architects (Hudson, 2010). The *Serpentine Pavilion* is an example which demonstrates a working process focused on capture and development of rule based systems using scripting.

The design process of **Frank O Gehry and Partners** (FG) is underpinned with physical modeling, followed by a scanning and then a rationalization using the computer to remodel the original form. In the *Barcelona Fish* project (see Fig.4.5), the physical Fish model was recreated by Rick Smith, a consultant from the aerospace industry. He used CATIA to define a parameterized surface that could be adjusted to find a close match to the original physical form and also extracted fabrication information from the model. The parametric model for this project acted as a master document for the project from which all the construction information was generated (Fig.4.6). Gehry Technologies was then formed to develop software based on the CATIA aerospace package. The result is the system *Digital Project* that includes parametric modeling and BIM tools (Hudson, 2010).



Fig.4.4 - Serpentine Gallery Pavilion 2005 by Alvaro Siza and Eduardo Souto de Moura with Cecil Balmond – Arup (source: <http://www.telegraph.co.uk/>)

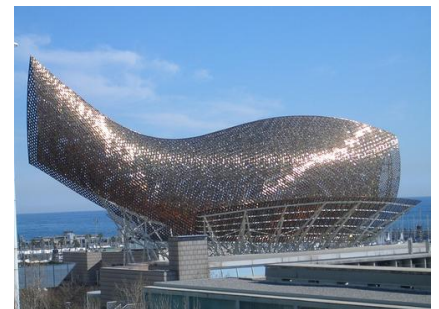

Fig.4.5 - The Barcelona Fish by Frank Gehry and Partners (source: www.buildingsatire.com)

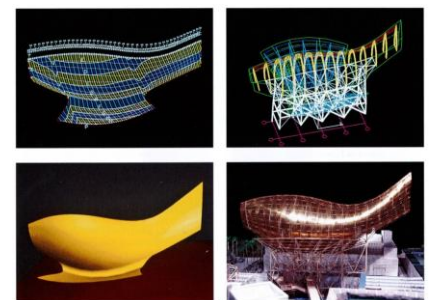

Fig.4.6 - Computer and built models for Gehry's fish sculpture (1992) in Barcelona (source: <https://mafana.wordpress.com>)

4.2 CASE STUDY 1: AVIVA STADIUM



Fig.4.7 – Aviva Stadium in Dublin by Populous architecture (2010) (source: www.archilovers.com)

The Aviva Stadium in Dublin (see Fig.4.7) is the first stadium to be designed from start to finish using parametric modeling software (Shepherd, et al., 2011). The project of the stadium was designed by Populous (formerly HOK Sports Architecture), who assert that the parametric design process was the most important aspect of the project, because it allowed them to maximize the efficiency of the overall design and the refinement of the building's exterior skin. It also assured the smooth collaboration between Populous and Buro Happold (the engineering firm for the project) and helped to avoid errors and save time (Jabi, 2013). As previously referred HP is a group where Generative Design already plays an important role. In this section we describe the development of the Aviva Stadium and we explain how Generative Design was integrated in the design process and the benefits that GD provided in terms of time and cost compared to a traditional approach to modeling.

The initial stages of the project (the concepts and studies) were explored through static 3D models implemented in McNeel's *Rhinoceros* platform. This early work allowed the architects to quickly explore the development and logic of the form's geometry, which consisted in three elements: (1) the footprint of the stadium, which was composed of eight tangential arcs, (2) the plan of the inner roofline also composed of eight tangential arcs and (3) a radial structural grid that became the supporting system of the stadium's skin, which works as a facade and a roof (Jabi, 2013). These sections had to

be manipulated to correspond, not only to the general plan of the stadium, as also to accommodate the functional requirements of the interior.

After the model was complete, it was rebuilt in Bentley's *Generative Components* (GC). The coordinates of the Rhinoceros model were extracted and imported into a spreadsheet to be then referenced in the GC model. Within the GC model certain variables and principles were established, which allowed the final form of the model to be maintained. In other words, it allowed the model to be parametric, with internal variables and also constraining the geometry to certain grid-lines and boundaries (Shepherd, et al., 2011). According to the designers this was the most critical aspect of the design, because it allowed the designers to control the overall shape and the design of the stadium's outer skin. Populous and Buro Happold together established the principles by which the structural roof members would relate to the parametric skin. They developed a framework in which the information could be exchanged by both teams, i.e. they could work simultaneously on the model in different offices: the engineers developed the structural elements and the architects the original script to define the cladding layout. As both parts were dependent on the input from a single Excel document, the entire design of form, structure and cladding could instantaneously be amended and redefined by altering the parameters defined in the Excel file.

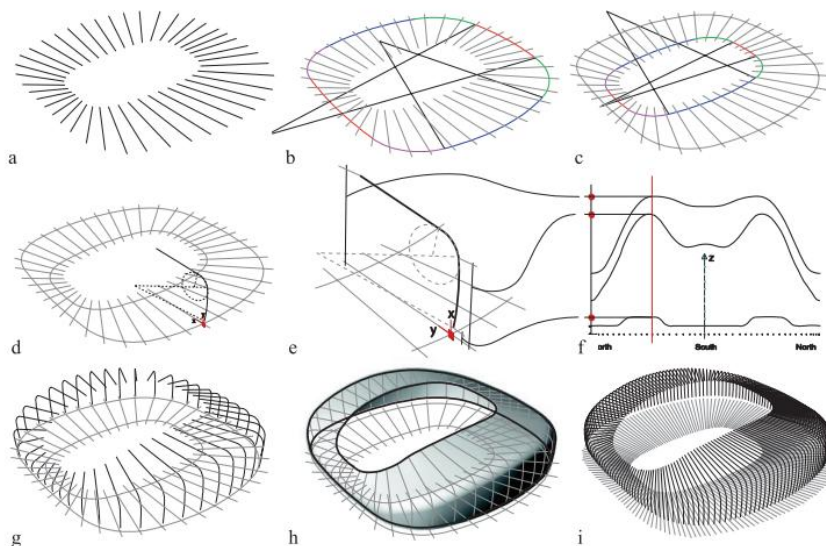

Fig.4.8 – Parametric definition of the stadium's geometry: a- radial grid of the structure of the roof bays; b- definition of the footprint of the stadium; c- definition of the inner edge of the roof; d- definition of the origin of each sectional curve; e- definition of the section curve; f- definition of the vertical coordinates for each section curve; g,h- construction of each sectional curve and then the lofting of a surface through those curves; i- subdivision of the radial roof bay grid into mullion grid lines (source: (Shepherd, et al., 2011))

The structural concepts were tested by the structural engineering team using a parametric model based in Excel linked to the Robot Millennium structural analysis package. Through the early studies the overall structural concept for the roof was formed and, once the architectural parametric model of the stadium was complete it was relatively simple to integrate the roof structure into the GC model.

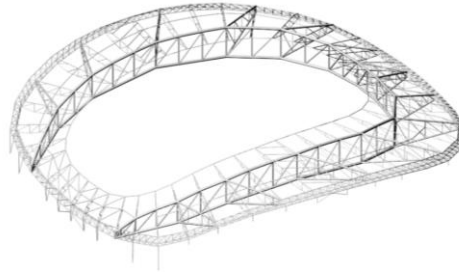

Fig.4.9 – Structural elements output from parametric model (source: (Shepherd, et al., 2011))

The real benefits of taking a parametric approach to structural modeling were seen through the integration with structural analysis software. The GC parametric model was extended through its C# programming interface (a special C# program was written within GC) to export a structural analysis model ready for calculation in Robot, which allowed the information of the PM to be shared with the structural analysis package with minimal human intervention (Shepherd, et al., 2011). These extension of GC facilitated a more collaborative approach to design and allowed each discipline (architectural and engineering) to respond quickly to the other's requirements and a whole design solution was achieved. The same happened with the calculation of the facade cladding system, i.e. the calculation of all the parameters for configuring rotation angles of panels and brackets and spacing along mullions. This information was extracted from the model and then required as part of the construction documentation package.

The Aviva Stadium is a project executed during a transitional period in computer-aided design technology and it demonstrates two important benefits of a parametric approach: (1) without this approach this stadium and similar projects would have been more error-prone and more expensive to construct and (2) demonstrates how parametric tools can allow designers to widen their exploration of forms and simultaneously maintaining rigorous control over all aspects of their design (Jabi, 2013).

4.3 CASE STUDY 2: BEIJING NATIONAL AQUATIC CENTER



Fig.4.10 – A photography of Beijing National Aquatic Center (source: <http://www.archello.com/>)

The Beijing National Aquatic Center or Water Cube (see Fig.4.10) was designed by PTW Architects, China State Construction and Engineering corporation, and ARUP. As in the previous case Study, ARUP is also a group where Generative Design plays a great role. Generative Design was also integrated in the design process of this project and in this section we explain how.

The cladding of the project derives from the structure of water bubbles in the state of aggregation found in foam. Weaire and Phelan were two professors who developed a soap bubble structure by using an advanced 3D modeling approach. Based on this finding, the design team developed a parametric script that could construct a volume of Weaire-Phelan foam in any size that they required (Crawford, 2009). This solution divides space into cells of equal size with the least surface between them and without leaving any empty space (see Fig.4.11). This solution pleased the ARUP's designers and engineers due to its geometry being highly repetitive, regular and buildable (Fernandes, 2013).

The building's interior spaces were carved out from the foam, leaving the bubbles that would wrap the building's structure. The parametric model was developed to automatically size the steel elements, supporting as much weight as possible to allow the roof to span long distances. In addition, physical models could also be three dimensionally printed directly from the parametric model (Crawford, 2009).

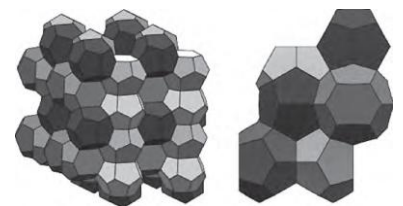

Fig.4.11 – Weaire and Phelan's proposal for portioning 3D space. The image on the left represents a cluster of repetitive units and, the image on the right represents the repetitive module (source: (Eastman, et al., 2008)).

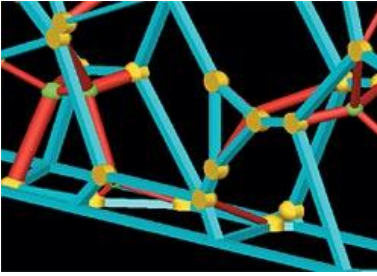

Fig.4.12 - CAD model of the structural system of the Water Cube Project (source: <http://architectureau.com/>)

The project was developed in two main stages: the competition submission and the design development. The competition period was limited due to the deadlines, so the team simply developed a method to generate a 3D model and the drawings for presentation in which they applied a scripting-base representation to model a wire-frame, in order to provide the 3D model of the structure (Fernandes, 2013). The 3D model created by the scripts consisted of elements and node spheres of the same size while rules defined how to handle elements of various lengths (Eastman, et al., 2008). To communicate the idea to the competition's jury, they used rapid prototyping to model the building's structure.

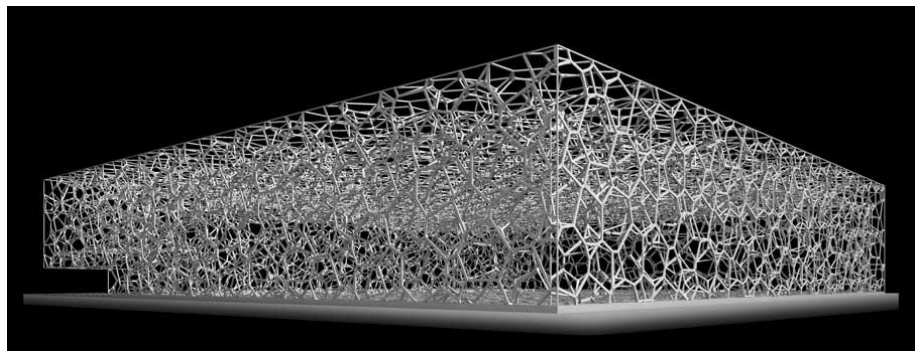

Fig.4.13 – Building's structure prototyping (source: <http://www.e-architect.co.uk/>)

During the competition period the team was concerned with the model and did not analyze the structure. However, in the beginning of the design development, the team used a wire-frame model not only to prove the geometry worked, but also to analyze and optimize the structure. They developed scripts to export the information to several type of files. The scripts were also used to create a 3D model which allowed them to visualize the model in different representations such as surfaces, solids or structural elements. The detailed drawings for construction and schedules were produced automatically from the 3D model and, indeed, they had created a system that took less than a week to generate the model and all the drawings even when a change was made to the model (Fernandes, 2013).

ARUP proposed prefabrication to ease the construction of the Water Cube project, however, the idea was rejected by the client in China. In this case the construction process was done manually with approximately 3000 workers onsite (Eastman, et al., 2008), instead of using CNC machinery to shorten the fabrication time, as it was done in other countries (Fernandes, 2013).



Fig.4.14 – Interior view of the Water Cube pavilion showing the almost complete structure (source: (Eastman, et al., 2008))

The Water Cube pavilion is a unique project, where the structural design was a big challenge. Analyzing the structure as many times as needed, would be a hard-working process and very time consuming. To solve this limitation, ARUP developed a script to automatically select the elements sizes through an optimization process written using a genetic algorithm. The algorithm checked the entire structure and allowed the team to test different design configurations to then receive feedback information. This process allowed the propagation of changes in any member of the structure to all the related elements and, consequentially, it enabled the creation of a complex structure, which could be structurally optimized and that saved millions of dollars on design costs compared to traditional approaches (Fernandes, 2013).



Fig.4.15 – Interior of the Water Cube pavilion (source: <http://www.arup.com/Projects/>)

PART II

A FRAMEWORK FOR THE GENERATION OF CONTEMPORARY FACADES

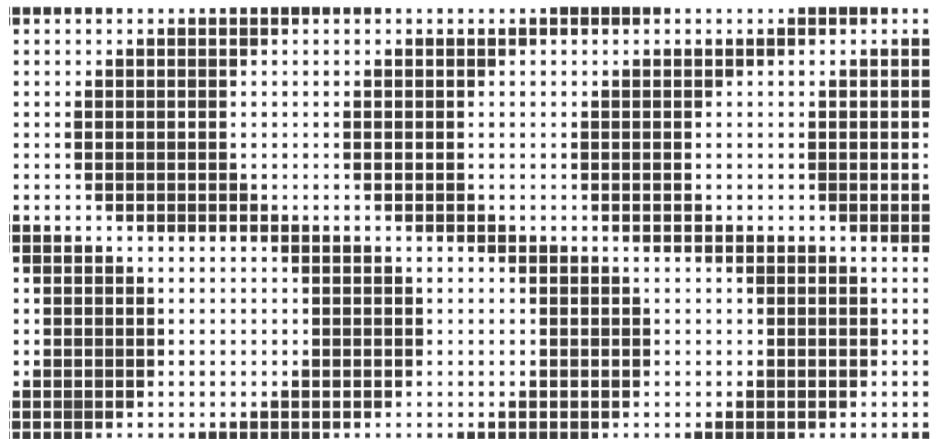
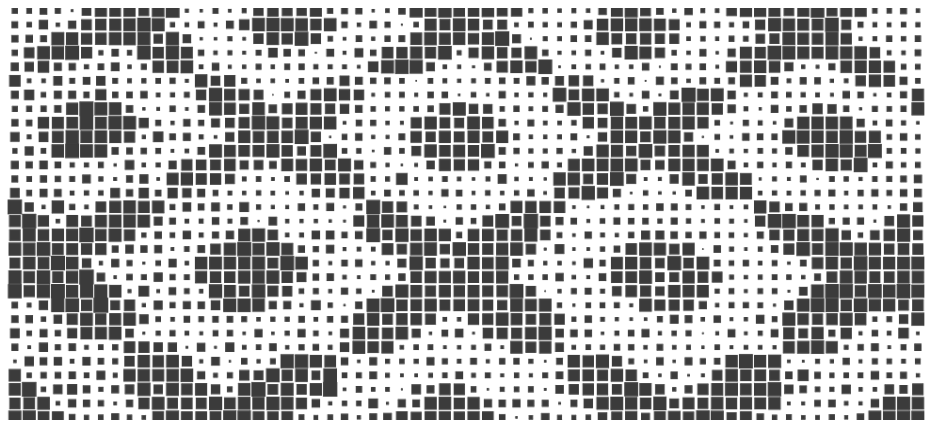
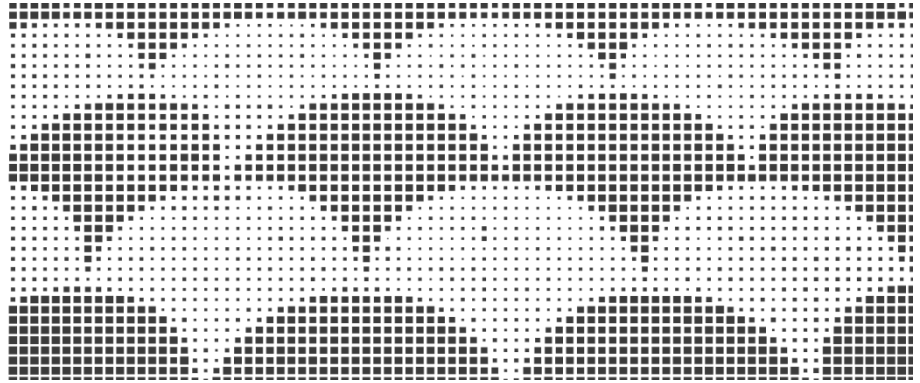

Facade designs might still require a lot of effort to invent, experiment, and produce. It is important, then, that this effort be as small as possible. The work presented here proposes a systematic methodology for the development and composition of algorithmically-based facade patterns.

As we will show, our methodology promotes the design exploration of facades and simplifies its adaptation to the ever-changing design process conditions.

Algorithmic-based Processes in Architecture

Creativity is characterized by unconsciousness and inaccuracy (Bukhari, 2011) and, thus, is better served by a design process that embraces change. Traditional tools do not easily support change because they require too much time and effort to change models. On the other hand, the computer became a very important tool of the design process which changed, and still changes, the way architects design (Kolarevic, 2003). The new technologies allow design exploration to go far beyond the traditional possibilities, thus promoting the development and spread of complex shapes, new patterns and advanced production technologies. Computers "*do not eradicate human imagination but rather extend its potential limitations...it provides the means for exploration, experimentation, and investigation in an alternative realm*" (Terzidis, 2003).

Through Generative Design, instead of going directly from the idea to the design, architects produce an intermediate algorithmic-based description of a design (Leitão, 2013). Parametric design is a type of GD in which the parameters of a particular design are declared, rather than its shape (Kolarevic, 2003). This approach has the ability to generate different instances of a design. Each instance represents a unique set of

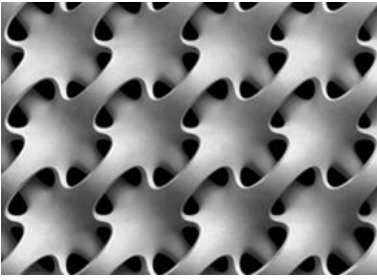

Fig.6.1 - Continua Screen, design 1 - pattern developed by Erwin Hauer in the 1950's (source: (Hauer, 2004))

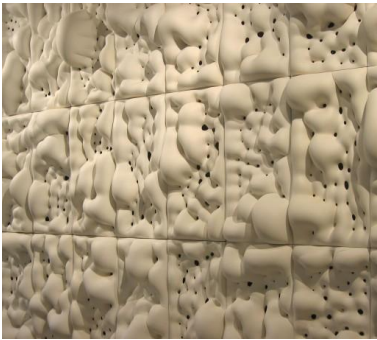

Fig.6.2 - P-wall (2006) developed in Banvard Gallery, Knowlton School of Architecture, Ohio State University, USA (source: <http://matsysdesign.com/>)

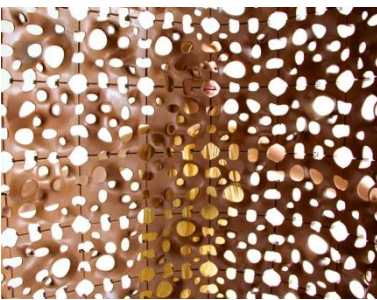

Fig.6.3 - Sawdust Screen in Walnut material, by Emerging Objects (source: <http://www.emergingobjects.com/>)

transformations based on the parameters given values (Barrios, 2005), which consequentially, allows the designer to freely explore a larger solution space of the design briefing/program. Ultimately, this leads to the assessment of solutions that would be difficult to generate with traditional design methods. An algorithmic based design method can easily accommodate changes in the proposed solutions, as the dynamics of the design process alter the state of the design brief and its programmatic nature. In fact, our Framework describes the design as a program written in a formal programming language.

We formalized the design of several different skins while, at the same time, we planned the combination between different design parts to enable their fusion in multiple possible designs. For this we had to divide the process behind the generation of a facade into different parts and then subdivide those parts once more if necessary. This division was the starting point for the definition of a classification, which aims to help the designers in the selection of the algorithms that better suit their design intents. The classification was divided into some categorical dimensions and the combination of the algorithms of each dimension was made to generate a unique facade model. As a result, we can combine and simulate several facades only by using the pre-defined functions of our framework and, if necessary, we can implement a more specific algorithm to complement a design.

The second part of this dissertation provides the classification strategy of our framework and an overview of the complete classification (chapter 6), a practical application of the classification on real facades (chapter 7), an analysis of the process behind the generation of a facade using the Library of Birmingham facade as an example (chapter 8), a practical application of the framework, i.e. its application to generate real and imagined facades (chapter 9) and a description about other possible applications of our framework (chapter 10).

6 ALGORITHMIC FACADES

In this thesis, we discuss the development of a computational framework for the design of facades. Our work started with an analysis of a large corpus of contemporary facades. The research of facades includes facades with complex and highly curvilinear geometries, such as the Selfridges building in Birmingham (Fig.6.4), regular facades with complex patterns such as the Monteagudo Museum (Fig.6.5), facades similar to webs like the French Pavilion in Shanghai Expo 2010 (Fig.6.6), transparent facades with printed elements as the Louis Vuitton Flagship Store in Fifth Avenue (Fig.6.7), etc. After analyzing this set of contemporary facades, in a computational point of view, we conclude that the algorithms used to produce some of the facades' parts are coincident. This suggested the possibility of organizing the algorithms in a logical strategy, in order to facilitate its use for the design of facades. Although the facades "design" may have similarities from an algorithmic point of view, in the eyes of the architect their aesthetic is completely different.

We present two important contributions with this thesis: The first contribution is a classification of facades into different categorical dimensions that we consider computationally relevant, which was based on the mentioned analysis of a large corpus of contemporary facades. This classification generates a multi-dimensional space where an entire facade or parts of a facade can be located. We submit a facade design to all the classifying dimensions from which we receive a set of algorithms to generate that same facade. By using the set of algorithms available in this Library, the designer saves a lot of time in the facade's generation process and, also, in the design experimentation.



Fig.6.4 - Selfridges Building in Birmingham, UK (source: <http://www.contemporist.com/>)



Fig.6.5 - Monteagudo Museum in Murcia, Spain (source: <http://www.archdaily.com/>)



Fig.6.6 - French Pavilion in Expo Shanghai 2010 (source: <http://www.tridonic.com/>)

The second important contribution of our work comes, then, from the elaboration of a set of fundamental algorithms and strategies that address the needs of the different dimensions of this space. Some of the locations in this multi-dimensional space can use a specific computing approach that is adequate for the creation of the designs that match the intended facade.

Other locations, representing less common kinds of facades, might not have a specific computational solution, but our experience shows that it is possible, using the tools available in our framework, to quickly implement the particular solution required by that facade.

6.1 CLASSIFICATION STRATEGY

The wide variety of contemporary facades has already promoted several different classifications. The first example is Moussavi's classification, based on three main concepts: Depth, Material and Affect (Moussavi & Kubo, 2008). The concept Depth organizes the facades from the thinnest to the deepest, the concept Material organizes the facades according to the way they manipulated their material in order to structure the ornament, and the last concept Affect results from the combination of the concepts Depth and Material, which together produce unique sensations.

The second classification of facades was structured by Ben Pell in his book "The Articulate Surface" (Pell, 2010), where he organized the case studies according to two main concepts: The first one is the facade's primary means of production and distribution and is composed by five sub-categories such as Applied, Perforated, Layered, Cast/Formed and Stacked/Tiled. In order to organize the facades inside these categories, three questions need to be answered: *What are the characteristics of the surface? How has the surface been produced? What are the cultural motivations behind the project?* The second concept refers to the place where the facade is located, within the rational matrix of material articulation and the surface content (the coordination of ornament, decoration and effect conditions).

As our framework aims to help the designers with the generation of facades, we propose another classification which is more helpful for designers who intend to use a computational approach. We started by sketching several



Fig.6.7 - Louis Vuitton Flagship Store in Fifth Avenue in New York, USA. (source: <http://www.archdaily.com>)

possible compositions and strategies for this categorization of facades and, then, we discussed the relevance of each proposal until we reach an agreement. We believed the classification should be based on the characteristics which are relevant from the computational point of view.

This idea was considered after we spent quite a long time programming a substantial set of existing facades with totally different designs. We noticed that, when we were programming any type of facade, the majority of the designs were phased according to the algorithmic thinking. Thus, we decided that this same process should organize the methodology and strategy on which the classification is based.

In our classification the facades are classified into different categorical dimensions that we consider computationally relevant. This multidimensional classification guides the designer towards a library of functional operators, each addressing the generation of different designs of facades. In practical terms, the designer matches his ideas for a particular facade with the categorical dimensions which, in turn, guide him in the selection of the most appropriate algorithms for the generation of the idealized facade. This guiding process is not intended to replace the role of the designer, as he is still responsible for the division of the whole design into parts, for establishing the dependencies between them, for instantiating and combining the different algorithms that handle each design part, and for the additional scripting that might be needed to handle specific circumstances of the design brief.

Unfortunately, because the making of architecture is highly dependent on specific circumstances of the design brief (e.g. program, site, and budget), it is very unlikely that the exact same approach can be used in a different project. However, modular programming techniques allow the designer to adapt and reuse ideas in different projects which imply, at least partially, the systematic application of a set of functional operators, thus reducing the initial investment required.

6.2 DESIGN STAGES & CATEGORICAL DIMENSIONS

There are several stages in the design of facades and the presented framework takes them into account. These stages are in accordance with the computational logic of the facade design and each one corresponds to one or more dimensions of our classification. The stages are:

- (I) The definition of the facade's geometry.
- (II) The generation of the facade's elements, which includes the definition of their geometry, type of deformation and size variation.
- (III) The distribution of the elements, which is responsible for mapping and rotating the elements on the facade.
- (IV) The generation of the facade's final appearance which produces the type of facade's finish and selects the material or color to apply.

The framework is organized in eight categorical dimensions, which have an important role in the different steps of the facade's generation: (1) Facade's Geometry, (2) Element's Geometry, (3) Element's Distortion, (4) Element's Size, (5) Element's Distribution, (6) Element's Rotation, (7) Color & Material, and (8) Facade Articulation, where each dimension corresponds to a set of related computational functions. This classification generates a multi-dimensional space where parts of a facade can be located.

The important result of our work comes, then, from the identification and implementation of a set of fundamental algorithms and strategies that address the needs of the different dimensions of this space. Some of the locations in this multi-dimensional space can use a specific computational approach that is adequate for the creation of the designs that match the intended facade. Other locations, representing less common kinds of facades, might not have a specific computational solution, but our experience shows that it is possible, using the range of tools that we developed, to quickly implement the particular solution required by that facade. This is intentional, as the goal of the framework is not to limit the facades that can be produced but, instead, to speed up the development of facades. Moreover, when additional algorithms are developed, they can be incorporated in the framework and, thus, further improve the matching process of subsequent facade designs.

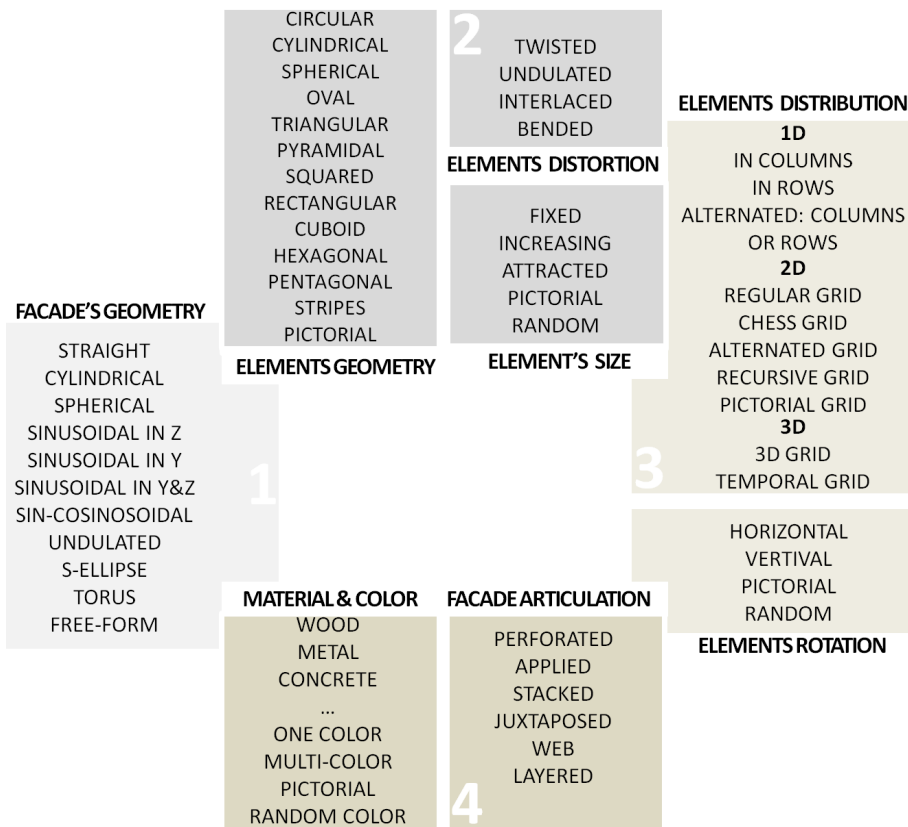

Fig.6.8 – Image synthesis of the classification's categorical dimensions. The eight dimensions are organized in four different sets, which correspond to the design stages: 1- definition of the facade's geometry; 2- definition of the facade's elements; 3- distribution of the elements; 4- facade's final appearance.

The Fig.6.8 shows, synthetically, all the categorical dimensions of the classification. The corresponding algorithms are within the boxes, which correspond to the dimensions. In the next sections we discuss each of the eight categorical dimensions, one by one.

6.2.1 FACADE'S GEOMETRY



Fig.6.9 - Facade Geometry: Straight Facade - Formestelle Office Building in Töging am Inn, Germany (source: www.dezeen.com)

Given that designers want their models to be flexible, when defining the underlying principle of a geometry, they should be able to control and change it easily, so that many design instances can be generated within the same geometrical principle. This idea guides our first dimension, named *Facade's Geometry*. For each different geometry, our framework provides a $\mathbb{R}^2 \rightarrow \mathbb{R}^3$ parametric function that describes the shape of the facade. For example, $f(u, v) = XYZ(u \times 5, 0, v \times 10)$, where XYZ is the Cartesian coordinate function, represents a five-by-ten rectangle on the XZ plane. Naturally, other coordinate systems can be used, such as the Cylindrical, represented by function CYL, and the Spherical, represented by the function SPH, to which can be applied transformations, such as translation, rotation, etc. The coordinate system transformations are related to a spatial location of reference, capable of codifying the transformed referential, which, for brevity, we will omit. To simplify the presentation, each parametric function $S(u, v)$ will range over the domain $0 \leq u \leq 1, 0 \leq v \leq 1$.



Fig.6.10 - Facade Geometry: Cylindrical Facade - Suzhou SND District Urban Planning Exhibition Hall in Jiangsu, China (source: www.archdaily.com/)

To make the framework more flexible, we rely on the use of anonymous functions, i.e., functions which do not have a name, and higher-order functions (HOFs), i.e., functions that receive other functions as arguments and/or compute other functions as results (Leitão, et al., 2012).

As an example, consider the facade of the *Formstelle Office Building* (Fig.6.9) which is completely planar. This is classified in the Facade's Geometry dimension as *Straight*, which, depending on a width w and height h of the facade, is defined by the equation (6.1):

$$Straight(w, h) = \lambda(u, v).XYZ(u \times w, 0, v \times h) \quad (6.1)$$

Note that Straight is a HOF that returns an anonymous parametric function that represents a delimited region on the XZ plane. The λ symbol is the λ -calculus notation for an anonymous function (Leitão, et al., 2012).

For a different example, consider the *Suzhou SND District Urban Planning Exhibition Hall* (Fig.6.10), which, for radius r and height h , is described by the following function (6.2):

$$Cylindrical(r, h) = \lambda(u, v).CYL(r, u \times 2\pi, v \times h) \quad (6.2)$$

Finally, consider the sinusoidal facades, which are very common in recent architecture (see Fig.6.11, Fig.6.12, Fig.6.13 and Fig.6.14). The sinusoidal HOF is:

$$\text{sinusoid}(a, \omega, \phi) = a \times \sin(2\pi\omega x + \phi) \quad (6.3)$$

where a is the amplitude of the sinusoid, ω is the angular frequency, i.e. the number of cycles per unit length, and ϕ is the phase. However, there are more than one type of sinusoidal surfaces. Some, such as the one in Fig.6.11, have the undulation in the XY plane, thus producing a horizontal wave. This type of surface is defined by function (6.4):

$$Sb(w, h, a, \omega, \phi) = \lambda(u, v). XYZ(u \times w, u \times \text{sinusoid}(a, \omega, \phi), v \times h) \quad (6.4)$$

The undulation can also vary along the facade's height, thus producing a vertical wave. The GT Tower East in Seoul, visible in Fig.6.12 is an example of a building with this kind of geometry, which is defined by the following function, where the sinusoid is now dependent on the parameter v instead of u :

$$Sc(w, h, a, \omega, \phi) = \lambda(u, v). XYZ(u \times w, v \times \text{sinusoid}(a, \omega, \phi), v \times h) \quad (6.5)$$

In addition, there are also facades where the undulation occurs along two axes, i.e. a simultaneous waving in two different directions. A first example of a facade with this type of geometry is the *Mediopadane Station* in Bologna (Fig.6.14), which is defined by the function (6.6):

$$Sd(w, h, a, \omega, \phi) = XYZ \left(\begin{matrix} u \times w, \\ \left((v \times h) - \frac{h}{2} \right) \times u \times \text{sinusoid}(a, \omega, \phi), \\ (v \times h) + (u \times \text{sinusoid}(a, \omega, \phi)) \end{matrix} \right) \quad (6.6)$$

Other example is the *Boiler house at the Guy's Hospital, in London* (Fig.6.13), which has the undulation also along two axes and is defined by (6.7):

$$Se(w, h, a, \omega, \phi) = XYZ \left(\begin{matrix} u \times w, \\ u \times \text{sinusoid}(a, \omega, \phi) \times v \times \text{sinusoid}\left(a, \omega, \phi + \frac{\pi}{2}\right), \\ v \times h \end{matrix} \right) \quad (6.7)$$



Fig.6.11 - Facade Geometry: Facade with horizontal waving - Apartment house in Tokyo (source: <https://www.japlusu.com/>)

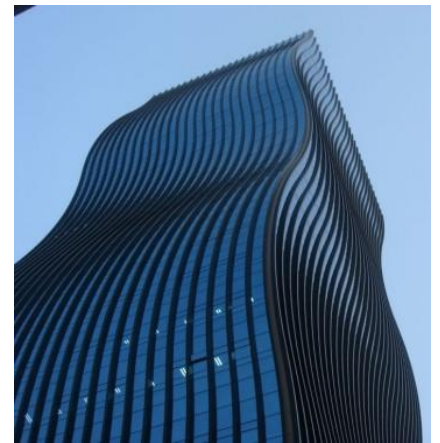

Fig.6.12 - Facade Geometry: Facade with vertical waving - GT Tower East, in Seoul (source: <http://www.contemporist.com/>)

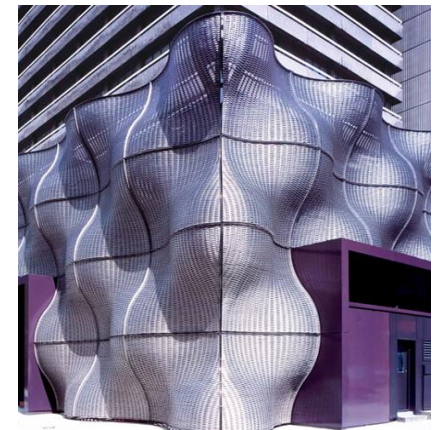

Fig.6.13 - Facade Geometry: Sinusoidal and co-sinusoidal Facade - Boiler House at Guy's Hospital in London, UK (source: www.dezeen.com/)



Fig.6.14 – Facade’s Geometry: Facade with vertical and horizontal waving - Mediopadana Station in Bologna, Italy (source: www.ediliziaeterritorio.ilssole24ore.com/)



Fig.6.15 - Selfridges Building in Birmingham, UK (source: www.contemporist.com/)

On the other hand, there are facades with completely irregular shapes, like the *Selfridges Building* in Birmingham (Fig.6.15), which are classified in the Facade’s Geometry dimension as *Free-Form*. In this last case, the designer creates the shape manually and then imports it into our framework, in which it is represented as another parametric function that results from the interpolation process of the surface.

Summarily, there are several geometries of facades in Contemporary architecture and the most common shapes are available within this dimension: Straight, Cylindrical, Spherical, Undulate, Torus, Free-form, etc. Each shape corresponds to a mathematical function, which describes the domain of the surface. The surface is then submitted to a sampling process and, based on that, it is then possible to produce grids of points. We decided to produce grids of points organized in sets of four points, from which it is possible to calculate the surface’s normal vectors and metric (see Fig.6.16).

Despite the fact that these mathematical functions are the basis of the whole process, they are later simplified into the algorithmic scripting. In practical terms, the designer uses this set of functions but through the combination of the programming code, which makes the whole process much simpler.

In the next sections we describe the other dimensions in a simplified manner, to facilitate the understanding of the using process of each one. We will now look into the Elements’ Geometry dimension, the next relevant dimension of our classification.

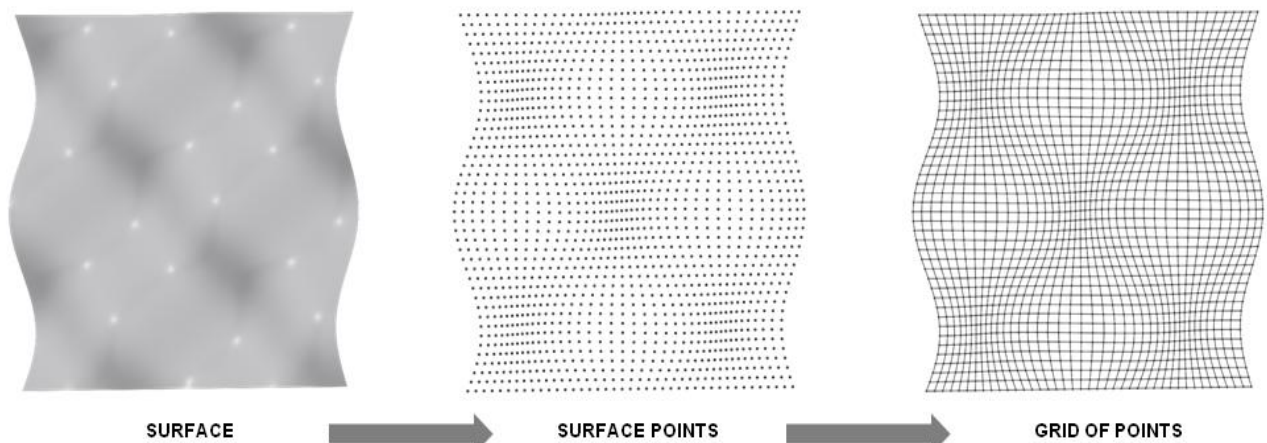

Fig.6.16 – Scheme of the process behind the Facade’s Geometry dimension: an initial surface is then submitted to a sampling process, from which results a mesh of points. Then, it is organized in a quadrangular matrix, defined by sets of four points.

6.2.2 ELEMENT'S GEOMETRY

The second dimension is called *Elements' Geometry*, and includes facades with any type of elements applied. There are several examples of facades where a particular kind of element is repeated, as is visible in Fig.6.17. The elements can be holes, appliqués, prints, reliefs, etc, and they can have several geometries. As we saw in the previous section, the facade's geometry defines the type of surface on which the elements will be placed, but before considering the placement of the elements, we need to describe the algorithms that shape them. As it happens with the *Facade's Geometry*, this dimension provides several pre-defined functions, representing geometric shapes. In many cases, these elements can be described by the same functions that describe the facade geometry. However, the elements geometry is more standardized and we can identify the most common shapes used, allowing us to pre-define a relevant subset of functions for the elements geometry. This dimension provides functions for several regular geometries, such as circle, triangle, square, hexagon, etc.

Contemporary facades with round elements are very common and can be classified as cylindrical, spherical, circular, etc. The New Center for Manufacturing Innovation (Fig.6.17) is an example of a facade with circular elements which are defined by the function *circle*. Another example is the facade of the *Hanjie Wanda Square* (see Fig.6.19), which is covered by several metallic spheres, produced using the function *sphere*. The following function illustrates the generation of spheres.

```
(define (spheres p0 p1 p2 p3) → p0, p1, p2 and p3 are the matrix four points
(let* ((p (quadrangle-center p0 p1 p2 p3)) → calculating the points' midpoint P
(r (/ (distance p0 p1) 2))) → calculating the radius' size using the surface's metric
(sphere p r ))) → creating a sphere centered on P point and with radius r.
```

Facades with quadrangular elements can be classified as squared, rectangular, cuboid, etc. Elements with shape of regular-polygons are also common in contemporary facades and can be classified as hexagonal, pentagonal, hexagonal-prism, etc. We provide customizable functions to produce regular polygonal surfaces or prisms, allowing the selection of the number of sides (enabling the generation of pentagons, octagons, etc). An example of a facade with hexagonal elements is The Cube in Milano



Fig.6.17 - Element's Geometry: Circular Elements - New Center for Manufacturing Innovation in Monterrey, Mexico (source: www.archilovers.com/)



Fig.6.18 - Element's Geometry: Hexagonal Elements - The Cube in Milan, Italy (source: www.e-architect.co.uk)

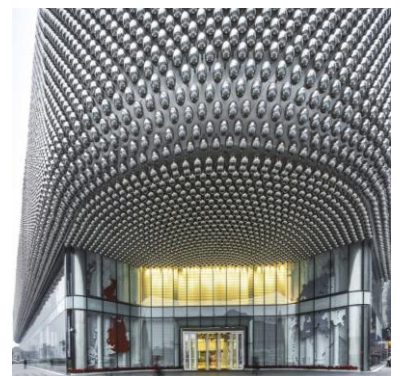

Fig.6.19 - Element's Geometry: Spherical elements - Hanjie Wanda Square in China (source: <http://www.archdaily.com/>)



Fig.6.20 - Element's Geometry: Stripes Elements - Aspen Art Museum, Aspen, USA (source: www.archilovers.com)

(see Fig.6.18). Facades with striped elements are classified as Stripes, producing continuous elements along the whole facade (Fig.6.20).

Besides the regular geometries, this dimension has also available algorithms for more specific geometries, which are classified as Pictorial. This set of algorithms receives an image of a shape and, then, it generates the elements with that same shape. An example of a facade with pictorial elements is *Mayfair House*, in London (Fig.6.21). This dimension also allows the designers to develop additional algorithms for generating a certain geometry, being possible to generate any type of element's design.

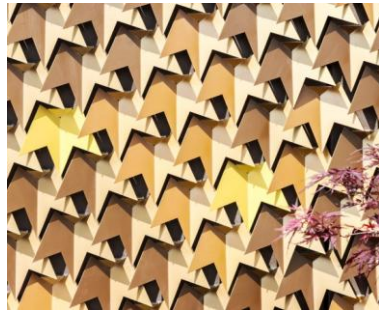

Fig.6.21 - Element's Geometry: Pictorial Elements - Mayfair House in London, UK (source: www.archilovers.com)

After selecting the geometry of the elements, we need to define the functional representation of the elements on the facade. The elements are produced by the function *element*, which receives a set of arguments, including the function that produces their geometry - *elementGeometry*. This is possible because the function *element* is a Higher Order Function and it can receive one or more functions as arguments. Besides the function that defines the geometry of the elements, the function *element* also receives other two functions as arguments, which we will explain in the following sections.

It is important to note that the previous function is a continuous function that generates an infinity of circles in a given delimited rectangle on the XZ plane. This means that we are not yet representing the actual distribution of circles, a topic that will be described in a later section.

6.2.3 ELEMENT'S DEFORMATION

Besides the geometry, the elements can also suffer a transformation. In this framework we consider two types of transformation wherein each one corresponds to a different categorical dimension. The first one includes different types of elements deformations, on which we will focus in this section. The second one controls the scale of the elements, i.e. the type of size variations, and we will develop this dimension in the next section.

Summarily, the type of geometry and transformation (including the type of deformation and size variation) constitute the arguments of the function *element*, which then generates the facade elements.

Now we will explain the Element's Deformation dimension. Deformation is a type of transformation where the natural form is changed. For example, we can deform a shape simply by twisting it along a direction/dimension. In this dimension, we have pre-defined some functions to produce several deformations on the elements. The command *Sweeping* (which displaces the element's section along a curve, possibly rotating it and/or scaling it) had a great relevance in this dimension's functions. It is noteworthy that the section, on which the sweeping is applied, has the geometry defined by the previous dimension Element's Geometry.

The first type of deformation available in this dimension generates twisted elements, such as those visible in the Huaxin Business Center (Fig.6.22). This type of deformation is called as Twisted. The generated elements result from a helical movement around their own axis, which is produced using the command Sweep with a rotation angle. This angle is applied to the element's section and it rotates the section as it is being extruded.

We named the second type of deformation as Undulated and it is also a particular case of the command sweeping. To generate undulated elements, we must select a curve with a sinusoidal distribution for the guiding curve, which is then used by the command sweeping to extrude the section (see Fig.6.23). The undulation's characteristics are defined by the values given to the amplitude and frequency of the sweeping curve.

The third type of deformation includes interlaced elements, which are classified as Interlaced. The method to generate interlaced elements is the same as the one to generate undulated elements, however, in this case the elements are strategically placed to become weaved. This is possible through the alternation of the sinusoid's phase value between zero and π , whether in the elements distributed vertically or horizontally. This type of deformation produces, as a result, a facade similar to the one in Fig.6.24.

The last type of deformation is classified as Bended and produces a deformation similar to a Zigzag, by the flexing of the elements according to the angles defined by the user. This type of deformation is also produced by using the command *sweeping*. However, in this case the guiding-curve for displacing the element's section must have a Zigzag shape. The Fig.6.25 is an example of a facade with bended elements.



Fig.6.22 - Element's Deformation: Twisted Elements: Huaxin Business Center in Xuhui, China (source: <http://openbuildings.com/>)



Fig.6.23 - Element's Deformation: Undulated Elements - Visitor Pavilion National Museum Palace in Het Loo, Apeldoorn, Netherlands (source: www.archilovers.com/)



Fig.6.24 - Element's Deformation: Interlaced Elements - Argul Weave Building in Bursa, Turkey (source: www.archdaily.com/)

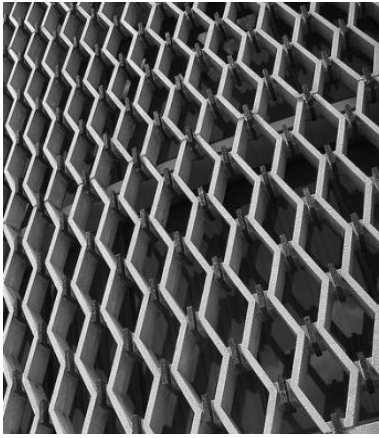

Fig.6.25 - Element's Deformation: Bended Elements - Pan American Health Organization Building, Washington DC, USA (source: <http://flickrhivemind.net/Tags/dc,paho>)

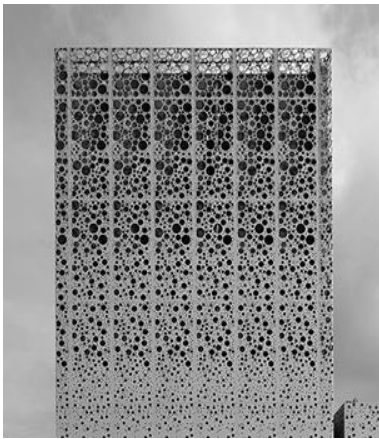

Fig.6.26 - Element's Size: Increasing Elements - The Tourist Office and Landscaping of Quinta do Aido, Portugal (source: www.archdaily.com)

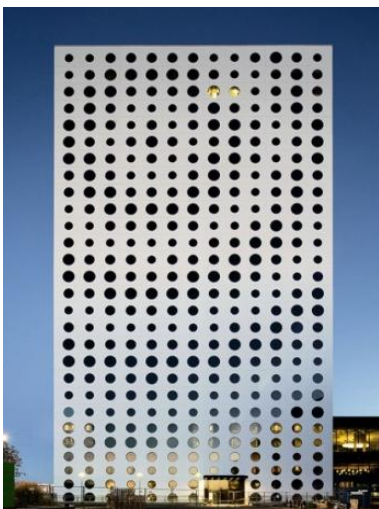

Fig.6.27 - Element's Size: Attracted Elements - Quality Hotel Friends in Sweden (source: www.archilovers.com)

6.2.4 ELEMENT'S SIZE

Elements' Size is the following categorical dimension and, as the previous one, it produces a transformation on the elements. In practical terms, it is quite different producing several elements with equal sizes than producing elements with different sizes. As it is visible in Fig.6.26 it is quite common to find contemporary facades where the element has a size that varies along the surface. For this reason, we have concluded that this dimension had plenty relevancy for our classification of facades.

Within this dimension, we have already pre-defined a set of functions capable of producing the most common types of size variations: Increasing size, Attracted size, Pictorial size and Random size. Otherwise, facades with elements of equal size are classified as Fixed.

Starting with the elements with an increasing or decreasing size variation, which are classified as Increasing/Decreasing Size. In these cases, the size of the elements increase or decrease linearly from one side of the facade to the other. The algorithms provided for this type of size variation produce a sequence of elements, in which the following element has always a bigger size than the previous one (or smaller in the case of decreasing size variation). The facade in Fig.6.26 is an example of a possible end result of the application of this type of size variation.

Another type of size variation that is also frequent is classified as Attracted Size. This type of size variation scales the elements according to their distance to a point or a curve. We have also predefined a set of corresponding functions for the computation of this type of size variation. For implementing this functionality, the designer must select (1) the position of the Attractor-point, or the Attractor-curve, and (2) the magnitude of the attraction, i.e. the intensity of the effect of attraction in the facade elements. The facade in Fig.6.27 is an example of a building envelope with attracted elements.

There are also some facades with elements that vary their sizes in order to reproduce a certain image. We have also developed some functions to compute this type of size variation, which is classified as Pictorial Size. For implementing the provided functions, the designer must select an image,

which will be one of the arguments of the functions. The selected image is then analyzed pixel by pixel and, it is the color value of each pixel that controls the size of the corresponding element. The example in Fig.6.29 shows a facade with pictorial elements, which produce an image of a horse. The facade is composed by several perforations with a circular shape, which sizes vary according to the image respective tone.

Finally, elements with a random size variation are classified as Random Size and, in these cases, the function that generates the elements has a size parameter controlled by a random function, as is exemplified in the following function.

```
(define (spheres p0 p1 p2 p3) → the matrix four points
(let* ((p (quadrangle-center p0 p1 p2 p3)) → the grid midpoint (point P)
(r (/ (distance p0 p1) (+ 2 (random-range 0.1 0.9)))) → the radius' size is
controlled by a random parameter
(sphere p r ))) → creating a sphere centered on P point and with radius r.
```

Within our framework, there are some algorithms available already that are capable of producing several elements with random sizes. To implement this functionality, the designer only has to select the range of values (x_0 to x_1) between which the random values are selected. The facade in Fig.6.28 is an example of random elements.

To sum up, the Higher-Order function *element*, which is the function in charge of generating the elements, receives as arguments three functions:

1. A function from the Element's Geometry dimension- it describes the geometry of the element's section;
2. A function from the Element's Size dimension – it controls the type of size variation of each element;
3. A function from the Element's Deformation dimension - it produces a deformation on the elements.

In addition, the function *element* also receives the number of elements to produce horizontally (n) and vertically (m). Having the elements defined, in the following section we move our attention to the distribution of the elements on the facade's surface.



Fig.6.28 - Element's Size: Random Elements - Cascais House in Portugal (source: www.guedescruzarquitecto.wix.com)

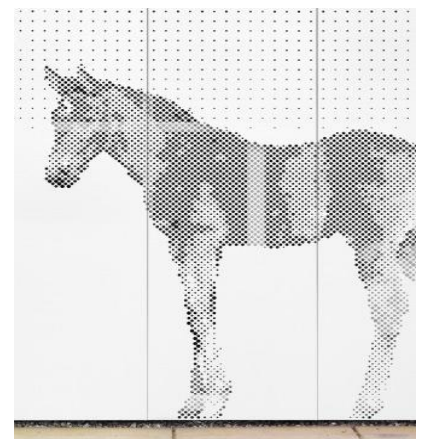

Fig.6.29 - Element's Size: Pictorial Elements - Hästsportens Hus in Sweden (source: <http://notedesignstudio.se/>)

6.2.5 ELEMENT'S DISTRIBUTION



Fig.6.30 - Element's Distribution: In Rows - commercial block in Tokyo by Japanese firm Amano Design Office, in Japan (source: <http://www.dezeen.com/>)

So far, we have described functions and functional operators that allow the construction of a functional description of the facade that includes its geometry, the element's shape, its transformation and its size variation. As we mentioned before, this description is a continuous function. However, most facades are discretized, in the sense that the function is not evaluated in its entire domain but, instead, in a *sampling* of its domain. It is this sampling that characterizes the Element's distribution, that is, the placement of the elements along the facade. This dimension classifies the facades according to the way elements are placed on the surface. In other words, the elements of the facade are mapped, not on a continuous domain, but on a discrete domain, which usually corresponds to the facade's dimensions height and length.

The distribution of the elements is organized in three groups to simplify the choice of the algorithms, and for each group we pre-defined a set of functions that produce each type of distribution. The first group includes the placement of the elements in columns or rows. In these cases, the facade domain is divided only along one variable, because this type of element's distribution only requires one point for placing each element on the surface (Fig.6.31).

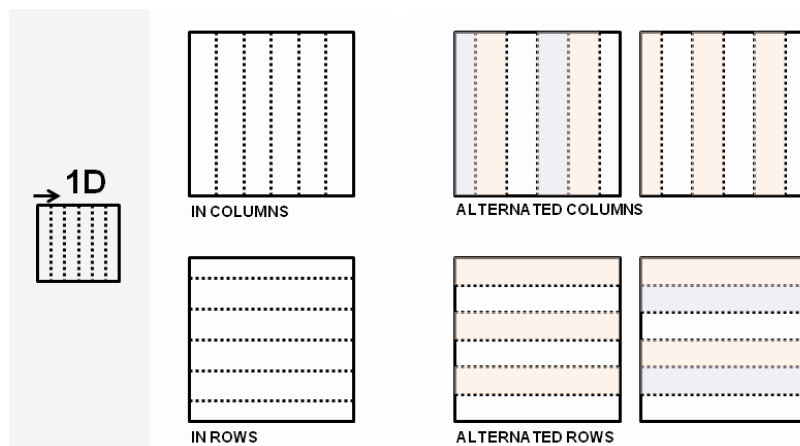

Fig.6.31 – Synthesis of the type of 1D distributions available within our framework.

Usually, this type of distribution is applied to continuous elements along the facade's length or height. If we look to the example in Fig.6.30, the metal stripes constitute the facade elements (which are continuous elements) and they are distributed in rows (see Fig.6.31) following the undulated shape of the facade.

In addition, there are facades where the elements are placed in columns (or rows) but they vary according to their position, i.e. there is a variation of the element (or its size, or rotation, etc) in every two or more columns. This type of distribution is classified as Alternated Columns (or Alternated Rows). The *Huaxin Business Center* (see Fig.6.22) is an example where the elements are distributed in alternated columns, because the stripes placed in the odd columns have a different rotation than the stripes placed in the even columns.

The second group of this dimension Element's Distribution includes the placements in grid, i.e. the same element is placed several times along the facade's height and length. In these cases, the domain is divided along two variables, μ and ν , and this division is according to the n and m values of the elements, which correspond respectively to the number of elements to place horizontally and vertically. As we have already mentioned in the section 6.2.1, our framework receives a parametric surface and, with the use of some operators, it automatically calculates the sampling of the surface's domain. From this process we obtain the set of points that constitute the facade. Although we already have the surface points, we believed that it would be much more useful, if we organized the surface points in quadrangles of four points: P_0 P_1 P_2 and P_3 (see Fig.6.32). The use of four points allows us to calculate the surface's normal vector at each position and also its metric. The surface metric has plenty relevancy in the control of the elements size, always adjusting the elements to the facade proportions.

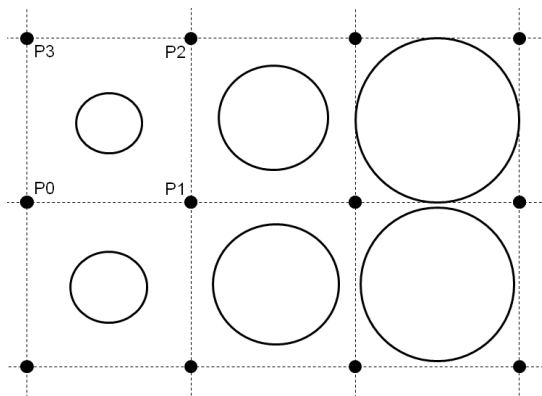

Fig.6.32 – The grid of points controls the size of the elements in order to fit the metrics.

In practical terms, the facade's domain is divided in a grid organized in sets of four points (the facade's length and height dimensions and geometry/shape are maintained), in which the elements are then placed. Within each set of four points, the elements may have any kind of shape.

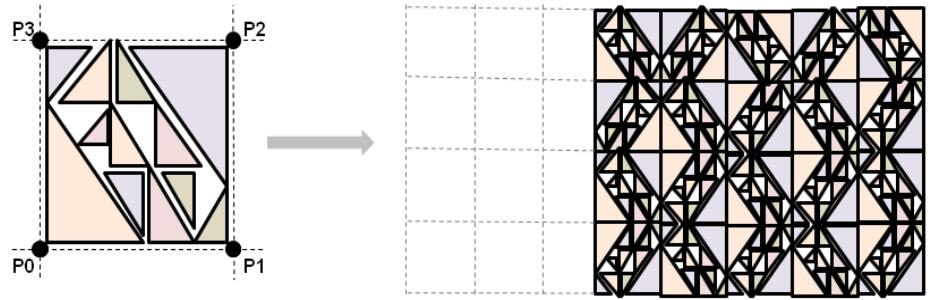

Fig.6.33 – Creation of an element between the four points (left-side) and the mapping of the element on the grid of points with random rotations (right-side)

In practical terms, the algorithms available in this subgroup of 2D distribution (distribution in two directions) are responsible for producing an element (which corresponds to the function *element*) in each set of four points, which were previously defined.



Fig.6.34 - Element's Distribution: in Chess-Grid - Knowledge center at St. Olav's Hospital, Norway (source: <http://www.archdaily.com/>)

Unlike the previous type of distribution in 1D, this distribution in 2D is more suitable for discontinuous elements due to the placement of a new element at each point or set of points. There are different types of distributions available which correspond to different grids of points, and now we will explain each of them.

The first type of distribution disposes the elements in a Regular-grid, i.e. the elements are aligned vertically and horizontally with each other, like the elements of the Hotel Quality Friends (Fig.6.27). The second type of distribution places the elements in a Chess-grid, i.e. the elements are aligned horizontally and vertically but in chess distribution. The facade of the Knowledge center at St. Olav's Hospital (Fig.6.34) has its elements distributed in a Chess-grid.



Fig.6.35 - Element's Distribution: Recursive Grid- The Cube, in Birmingham, UK (source: <http://www.wicona.co.uk/>)

The third type of distribution occurs when there is an overlapping of two grids, as it happens with the *Hanjie Wanda Square* (Fig.6.19). We classify this type of distribution as Alternated-Grid, given that the second grid is centered on the quadrangles of the first grid. A Recursive-Grid is another example of a distribution available within this second subgroup and it occurs when a surface is divided into a regular grid which is further randomly subdivided into sub-grids. The Cube in Birmingham is an example of a facade with a recursive distribution (Fig.6.35).

Another type of distribution is classified as Pictorial-grid and it maps the elements according to a design or image chosen by the designer. The

algorithms provided by this type of distribution dispose the elements in order to outline the geometry within the selected picture, like the facade of the Podcetrtek Sports hall, in Fig.6.37. The last type of distribution predefined within this sub-group is classified as Random-Grid, precisely because the element's distributions are based on randomness. The elements of the *Cascais House* have a distribution in Random-grid (Fig.6.28).

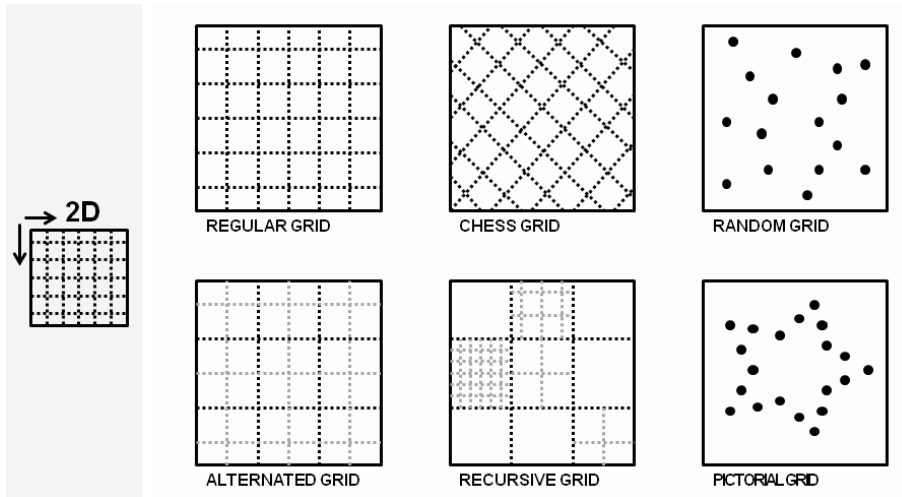

Fig.6.36 – The type of distributions in 2D available in the Framework.

The third group of element's distribution includes the 3D distributions, i.e. the mapping of the elements occurs along three dimensions, u , v and t . Two of them (the u and v dimensions) belong to the facade's surface, as in the previous subgroups, and the third dimension t might represent an additional spatial or temporal dimension. When the third value is a spatial value, it means that the dimensions of the surface (u and v) are not enough to correctly place the elements, thus being necessary a third value for their placement. On the other hand, when the third dimension t is a temporal value, it means that the placement of the elements varies with the course of time. Thereby, an element with a certain position in the present will change its position in the future. The facade in Fig.6.38. is an example of an elements distribution that varies with the course of time.

To sum up the functionalities described in this section, all of them are in charge of distributing the elements on a surface by resorting to one, two or three variables. These functions are also Higher-Order functions because they receive three functions as arguments:



Fig.6.37 - Element's Distribution: Pictorial Grid - Podcetrtek Sports Hall in Slovenia (source: www.archdaily.com)

1. A function *element* – the functions available know how the distribution is done but they need to know the element to distribute.
2. A function from the Facade's Geometry dimension – the functions available require the set of points on which the distribution will be done
3. A function from the Element's Rotation dimension – the functions available need to know if there is some kind of rotation, when distributing the elements and how the rotation is done (we will explore this dimension in the next section)

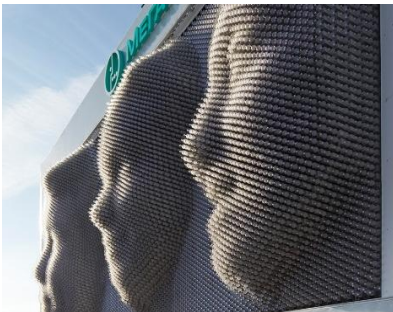

Fig.6.38 - Element's Distribution: 3D distribution - MegaFaces Pavilion Sochi 2014 Winter Olympics in Russia (source: <https://www.pinterest.com/>)

6.2.6 ELEMENT'S ROTATION

In some facades, the elements can be distinguished according to its rotation. This categorical dimension Element's Rotation is responsible for defining the rotation angle to be applied to each element at the time of their placement. The algorithms provided by this dimension are used as arguments in the function that distributes the elements along the facade (Element's Distribution).



Fig.6.39 - Element's Rotation: Horizontal Rotation - Huaxin Business Center in China (source www.archdaily.com/)

The most common types of rotation are pre-defined in our framework, which includes elements horizontally rotated and elements vertically rotated. If we look again to the facade of the Huaxin Business Center (see Fig.6.39), it is composed by twisted metal stripes distributed in Alternated-Columns. The distribution is in Alternated-Columns because the stripes placed in the even columns start with a different rotation angle than the ones placed in the odd columns. In practical terms, the stripes suffer a horizontal rotation at the time

of their placement, which means that we can classify them as Horizontally Rotated.

Facades whose element's rotation produce a general image or pattern are classified as Pictorial-Rotation. The mechanism is similar to the Pictorial-Size, available in the previous dimension Element's Size, but uses different rotation angles instead of different sizes. The elements of the Winery Gantenbein facade (in Fig.6.40) are an example of a Pictorial Rotation. In this example the bricks correspond to the facade's elements and they are rotated in order to produce an image, which in this case corresponds to an image of giant grapes.

The last type of rotation is classified as Random-Rotation and it applies a random rotation angle from a range of values selected by the designer — θ_0 to θ_1 .



Fig.6.40 - Element's Rotation: Pictorial Rotation - Winery Gantenbein by Gramazio & Kohler, in Switzerland (source: <http://www.gramaziokohler.com/>)

6.2.7 FACADE'S ARTICULATION

Articulation is a method or manner of jointing that makes the united parts clear, distinct, and precise in relation to each other (Borson, 2010). The concept of surface articulation was already defined in Chapter 2 and appeared in nowadays architecture "to be informed as much by the necessities of construction as by the opportunities to reclaim architecture's expressive potential" (Pell, 2010). The relation between the facade's parts can be done in different ways, thus providing facades designs with different appearances.

This dimension provides a set of algorithms that relates all the other dimensions in different ways, i.e. a relationship of subtraction, union or addition between the elements and the facade's surface. The functions provided by this dimension are also Higher Order functions, as in the previous dimensions, however, these functions receive as arguments all the algorithms provided by the other dimensions: Facade's geometry, Element's Geometry Deformation and Size, Element's Distribution and Rotation.

In perforated facades, the elements are subtracted from the whole surface, thus requiring a Boolean operation of subtraction. In these cases, the elements locate and shape the holes that constitute the facade, whose final appearance is similar to the example in Fig.6.41.

In applied facades the elements are united with the facade's surface, requiring a Boolean operation of union. In these cases, the elements constitute the facade's appliqués (the mosaics, reliefs, etc), which together with the surface constitute the very facade. Facades with printed elements are very similar to the ones with applied elements, as printed articulation also requires a Boolean operation of union. The only difference is in the facade's final appearance, since the elements constitute paintings or prints, instead of appliqués. An example of a facade with Applied articulation is represented in Fig.6.42, while Fig.6.43 is an example of a facade with Printed articulation.



Fig.6.41 - Facade's Articulation: Perforated Facade - House 77 by Diniso Lab in Póvoa do Varzim, Portugal (source: www.dezeen.com/)



Fig.6.42 - Facade's Articulation: Applied Facade - Mayfair House in London, UK (source: www.archdaily.com/)

A facade constituted by stacked elements has also a relation of union between its parts, but, in this case, the elements themselves produce the entire facade's surface. In case of a facade with Stacked articulation, the elements have to be distributed so as to be placed right next to each others. The Fig.6.44 is an example of a facade with Stacked articulation.

Facades with *Juxtaposed* elements also have a relation of union between the facade's parts, requiring the Boolean operation of union to join the elements together. Facades with a Juxtaposed articulation are constituted simply by the union of the elements, which constitute the final surface. This means the elements are not applied and unified with a surface, because the elements establish themselves the whole building's skin simply by their juxtaposition, such as the example in Fig.6.45.

Another type of articulation includes the facades that are similar to webs, i.e. the elements are crossed with each other, producing a facade similar to a grid. This type of articulation is classified as Web and, as similarly to the Juxtaposed articulation, the Boolean operation of union is required to unify the elements together, because the union of the elements constitutes the whole facade. The French Pavilion in Expo Shanghai 2010 is an example of a facade with Web articulation (Fig.6.46).



Fig.6.43 - Facade's Articulation: Printed Facade - Utrecht University Library in Netherlands (source: www.e-architect.co.uk/)

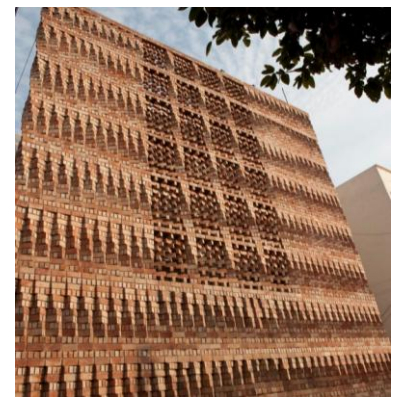

Fig.6.44 - Facade's Articulation: Stacked Articulation - South Asian Human Rights Documentation Centre, New Delhi (source: <http://anagramarchitects.com/>)



Fig.6.45 - Facade's Articulation: Juxtaposed Articulation - Aquacenter in Mantes La Jolie, France (source: www.e-architect.co.uk/)



Fig.6.46 - Facade's Articulation: Web Articulation - French Pavilion in Expo Shanghai 2010 (source: <http://assets.inhabitat.com/>)

Lastly, facades consisting of an overlapping of two or more layers are classified as *Layered*. Each layer may have the characteristics of one of the previous articulations (perforated, applied, etc) and then, it is overlapped with one or more layers and unified to constitute a unique facade.

As an example, consider the facade in Fig.6.47, which is an example of a facade with Layered articulation. The facade is composed by two layers and both layers are classified as Perforated, since they are constituted by several perforations with circular geometry. The facade's final appearance is characterized by the effect produced by the overlapping of both layers.



Fig.6.47 - Facade's Articulation: Layered Articulation - Dior Ginza, Tokyo (source: <http://archidose.blogspot.pt/2013/>)

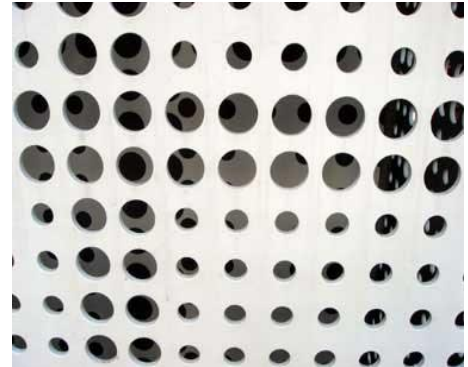

Fig.6.48 - Facade's perforations of Dior Ginza (source: www.arcspace.com/)

6.2.8 FACADE'S MATERIAL AND COLOR

The last categorical dimension of our classification of facades is called as Material and Color and it gives the materiality or color to the facade's model. If the facade's final appearance has materials in sight, the corresponding layer, or layers, will have the name of the chosen material and, thus, presenting the chosen materiality.

On the other hand, if the facade has colors as its finishing, the corresponding layer(s) will have the chosen color(s) as name(s) and, the facade's model will present the corresponding color(s) on its final appearance.

The algorithms provided by the dimension Material and Color constitute the third argument received by the function that generates the whole facade model (which is available in the Facade's Articulation dimension).

The materials used in a facade seem not to be directly connected with the selection of the algorithms. However, the material selected for a facade is often connected with the design of the facade. Since a certain type of design corresponds to a particular way of organizing the operations (which were used for generating a certain design) the selected materials turn out to be related with the type of algorithms used in the generation of the facade's model.

As an example, most of the perforated facades are made of metal (Fig.6.49). The same happens with facades of Web articulation and also facades with a complex geometry (see Fig.6.50).



Fig.6.49 - Facade's Material: Metal - an example of a perforated facade - Het Bushok in Netherlands (source: <http://www.archilovers.com/>)



Fig.6.50 - Facade's Material: Metal - an example of a facade with a complex geometry - Soumaya Museum in Mexico City (source: <http://www.archilovers.com/>)



Fig.6.51 - Facade's Material: Glass - an example of a printed facade - Historical Archive of the Basque Country in Bilbao, Spain (source: www.archilovers.com/)



Fig.6.52 - Facade's Colors: Pictorial Color - The Bisazza Foundation in Alte di Montecchio Maggiore, Italy (source: www.archilovers.com/)

Facades made of glass usually tend to have a Printed articulation between the facade's parts (Fig.6.51) and also complex geometries. Masonry facades often use the bricks to create games of fullness and emptiness, patterns, and also sensations of movement (see Fig.6.44).

Although the materials selection may have some influence in the selection and organization of the algorithms, this dimension Material and Color is only in charge of giving the desired materiality for the model's final appearance. This because, all of the previous dimensions, which were already mentioned in this section, are already in charge of making the same selection of algorithms but in a more organized and accurate way.

Otherwise, imagine the facade has colors in its final appearance instead of materials. The process behind the implementation of the provided algorithms is the same as in the case of materials, but instead uses the name of colors to name the layers.

It is a fact that Contemporary architecture did not set aside the use of colors and, many contemporary facades have been gaining more character and expression through the use of colors. The application of colors on contemporary facades creates different patterns, produces sensations of randomness by the use of random colors and, highlights some of the facade's parts or even the entire facade by using strong colors.

We can apply a single color or a set of colors on a facade. To apply a single color, the designer must select its corresponding name from this dimension. On the other hand, in case of sets of colors, the framework has available some functional operators which compute different combinations of colors. The first function is called as *randomColor* and it produces an apparent use of random colors (Fig.6.53), in which the layers' names have a certain randomness, thus producing random colors in the final model. The function *pictorialColor* is used to produce an overall image or pattern based on different colors (Fig.6.52). In these cases, the name of the layers are submitted to the same process as the functions *pictorial-size* and *pictorial-rotation* (already explained in the previous sections), but receiving colors instead of angles and dimensions.



Fig.6.53 - Facade's Color: Random Color - The Museum Brandhorst in Munich, Germany
(source: <http://www.archilovers.com/>)

6.3 CLASSIFICATION SYNTHESIS

In this section we presented our classification of facades and we described one by one all the eight dimensions. All the dimensions contribute for the generation of a facade's part, by providing the corresponding algorithms. In practical terms, the designer first selects the algorithms and, then, he implements them by combining the corresponding functions. As some of the functions are Higher-Order functions, they can receive the other functions as arguments, which provides greater flexibility to the framework. Summarily, the functions available within the Facade's Articulation dimension receive:

1. A function from the Element's Distribution dimension;
2. A function from the Facade's Geometry;
3. A function from the Material and Color dimension.

Relatively to the functions available within the Element's Distribution dimension, which are also Higher-Order functions, they receive as arguments:

1. A function from the Facade's Geometry dimension;
2. A function from the Element's Rotation dimension;
3. A function *element*.

The function *element*, which generates each element on the facade, is also an Higher-Order function and it receives as arguments:

1. A function from the Element's Geometry dimension;
2. A function from the Element's Size;
3. A function from the Element's Distortion dimension.

Lastly, we synthesize the whole classification, with all the categorical dimensions and the corresponding algorithms, to provide an overview of its structure. Fig.6.54 organizes the classification's dimensions with the corresponding options.

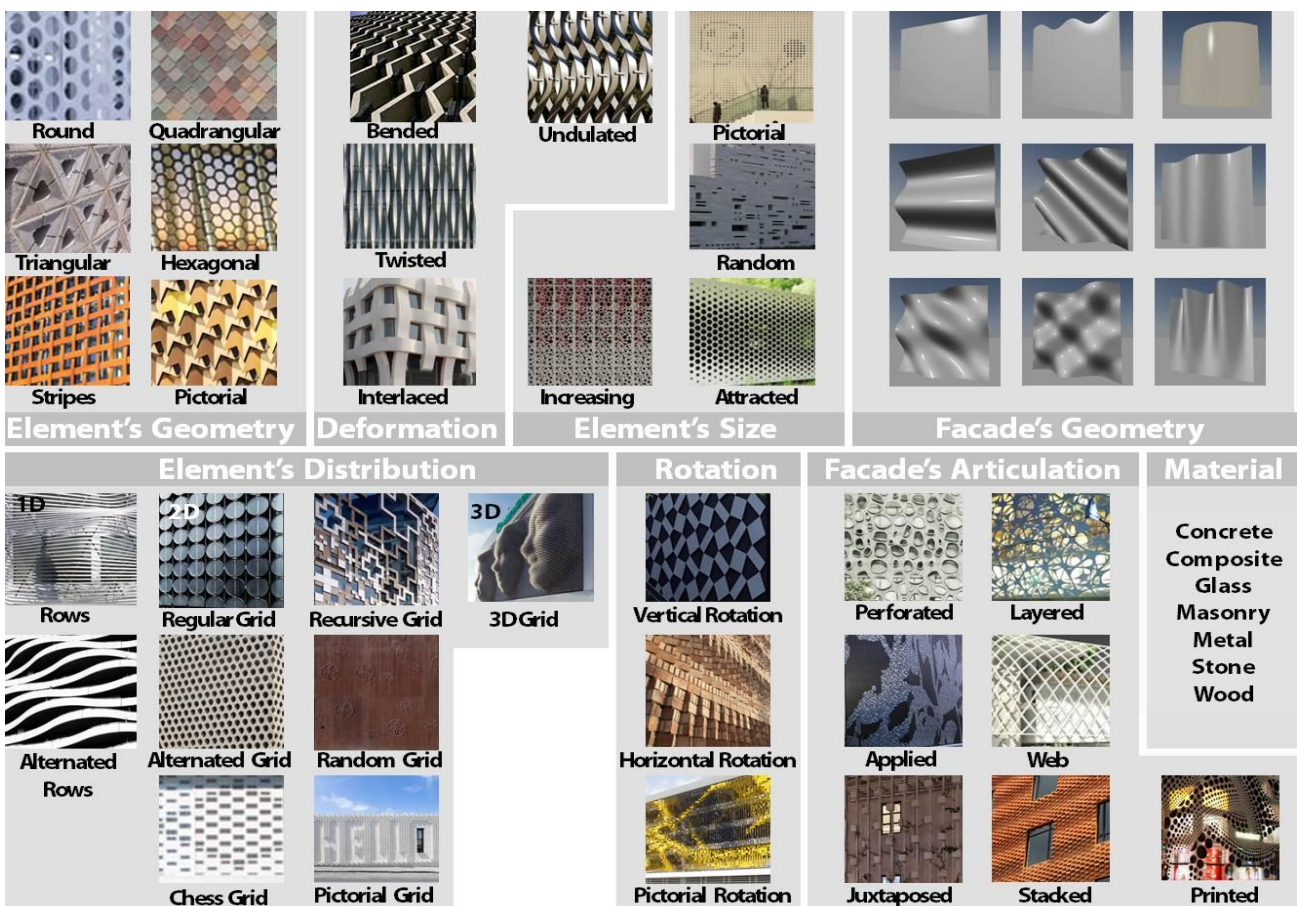

Fig.6.54 - Image Synthesis of the Facades' Classification: The names in white correspond to the categorical dimensions and, the names in the corresponding light grey rectangles are the options for each dimension.

7 THE APPLICATION OF THE FACADE'S CLASSIFICATION

In the last chapter we presented our classification of facades and the corresponding categorical dimensions. We started with a description of the classification's basic structure, then we made a detailed explanation of each of the categorical dimensions and we mentioned the functional operators available within each dimension, always illustrating with a real example.

In this section, we give some practical examples of how to use this classification of facades. The goal is to clarify how a facade design is classified/categorized. For this, we selected a set of Contemporary buildings, on which we apply our classification, i.e. we classify the building's facades according to all the categorical Dimensions.

These examples are intended to explain how this classification is applied in a design and, as this framework was created to help designers in the generation of facades, it is not intended to be applied on existing facades. Nevertheless, if we understand the process behind this classification by its application on existing facades, we also realize the methodology to have during the generation of a new facade design.

In the next two chapters, we describe the methodology behind the generation of a facade and we explain how the categorical dimensions contribute for the implementation of the functional operators, which then generates the whole facade model. Thereafter, we make practical examples of the intended application of this framework, i.e. how to generate a facade's model using some of the algorithms provided by this framework.

7.1 CLASSIFICATION OF FACADES

We have classified a total of eight buildings: (1) Campus Netzwerk Office, (2) Mediopadana Station, (3) Gantenbein Vineyard, (4) the Cascais House, (5) Quality Hotel Friends, (6) Suzhou SND District Urban Planning Exhibition Hall, (7) Utrecht University Library and (8) the Louis Vuitton Store in Japan. We make a small introduction of each project and, then, we classify the facades by using our classification of facades.

EXAMPLE 1 CAMPUS NETZWERK OFFICE, GERMANY

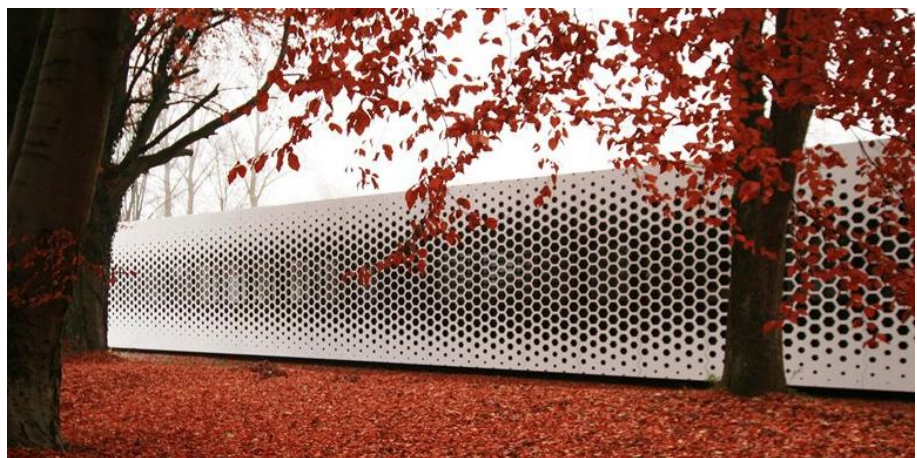

Fig.7.1 - Photography of the Campus Netzwerk Office (source: www.dezeen.com)

Campus Netzwerk Office (Fig.7.1) is a project of Format Elf Architekten and it was built in 2013. Its building skin seems like a honeycomb, which is composed by several hexagonal perforations. This pattern was calculated through a parametric process, which gives a contemporary appearance to the office. This facade design was produced using a parametric computer software and the manufacturing of the panels was made by laser cutting the metal surfaces with the generated pattern.

Now, we will proceed with the classification of this facade and we start by classifying it according to its material. The material used in the facade panels is aluminum. So, according to the dimension Material and Color we classify this facade as Metal. Relatively to the dimension Facade's Geometry, this facade is classified as Straight, because it is a regular surface as we can see in the image above.

The elements of this facade are the hexagonal perforations (see Fig.7.2) and we classify them as Hexagonal, according to their geometry. Regarding the type of size variation, we classify the elements as Attracted Size because their sizes vary according to the distance to an attractor curve. As the elements do not suffer any deformation, we do not classify the elements according to this dimension.

The following dimension is the Element's Distribution and, as we can see in the Fig.7.2 (on the right) the distribution of the elements occurs in an Alternated-Grid, i.e. the elements are vertically aligned but not horizontally aligned with each others. As the elements do not suffer any rotation at the time of their placement we do not classify them on this dimension.

Lastly, the articulation of this project is classified as Perforated, as its facade is composed by several hexagonal perforations.

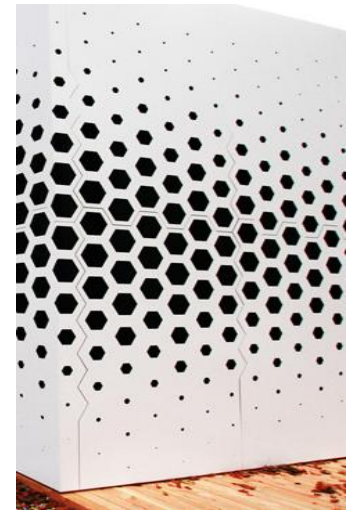

Fig.7.2 - Hexagonal Perforations of the Campus Netzwerk Office (source: <http://static.dezeen.com/>)

EXAMPLE 2 MEDIOPADANA STATION, ITALY



Fig.7.3 - Photography of the Stazione Mediopadana in Bologna (source: www.archilovers.com)

The Mediopadana Station (Fig.7.3) is a Santiago Calatrava's project for a railway station in Bologna and it was built in 2013. The station's structure is based on a repetition of a module of portals (with 25.40m length), which is composed by a sequence of thirteen different steel portals. Each module has a total of twenty five portals spaced 1m, and they are repeated in sequence until reaching the total building length, which is 483m. The resulting effect creates a dynamic wave propagating in both plan and elevation, which creates a three-dimensional volume with sinusoidal shape.

Proceeding with the classification, according to the dimension Material and Color this facade is classified as Metal. After analyzing the facade's geometry, we conclude that the facade follows a giant wave in two directions, being classified as Horizontally and Vertically Undulated.

The legs of the portals constitute the elements of the station's facade and we classify them as Stripes according to their geometry. They do not suffer any deformation nor size variation. This means the elements are not classified according to their deformation and, according to their size variation, they are classified as Fixed.

Now, we analyze the elements type of distribution and we conclude that they are placed in parallel to each other and, each element starts at the bottom of the facade and it ends at the top. Based on this analysis, we can classify the elements as In Columns.

This facade is only composed by the sequence of metal stripes, which produce the undulated geometry. The type of articulation of this project is classified as Juxtaposed, because the whole facade is composed only by the juxtaposition of the elements.

EXAMPLE 3 GANTENBEIN VINEYARD, SWITZERLAND



Fig.7.4 - Photography of Gantenbein Vineyard (source: <http://www.gramaziokohler.com>)

Gantenbein Vineyard (Fig.7.4) is a project of Gramazio and Kohler and it was constructed in 2006. This project is an extension of a vineyard and the initial design was a common concrete structure filled with bricks. However, through

a robotic production method it was possible to place each brick precisely according to a desired angle in a certain place. Depending on the rotation angles of the bricks, the light reflects differently producing different degrees of light. Comparatively to a computer screen, the different degrees of lightness, reflected by each brick, do the same effect as the pixels in digital images. This enabled the generation of images or patterns by using rotated bricks. This game of rotated bricks according to a pixel tone, produces an image, which is sensitive to the human eye as result. The image produced in this project's facade represents giant grapes.

Continuing with the classification, the facades of this project are made by bricks, which means we can classify this project as Masonry relatively to its material. The geometry of the facades are regular, so we classify them as Straight. The elements that constitute each facade are the bricks, which have a geometry classified as Rectangular. As the bricks do not change, having equal size and no deformation, we classify them as Fixed relatively to the Element's Size dimension and, relatively to the Element's Deformation, we do not make any classification.

Regarding the type of elements distribution, the bricks are piled and placed next to each other, with a distribution in Alternated-Grid. Relatively to the type of rotation of the bricks, they are horizontally rotated with an angle controlled to produce an image of giant grapes. We classify this type of rotation as Pictorial Rotation. Lastly, the articulation of this facade is made through the stacking of the bricks, which together constitute the whole facade's surface. We classify the type of articulation of this facade as Stacked.

EXAMPLE 4 CASCAIS HOUSE, PORTUGAL



Fig.7.5 - Photography of the Cascais House, Portugal (source: www.archilovers.com/)

The Cascais House (or Lifting House) is located in Cascais (Fig.7.5) and it was designed by the practice of Guedes Cruz Arquitectos. The original layout was changed to a more reasonable and practical contemporary residence in the middle of a lot which, although is not protected from the sandy winds prevalent in the region, takes advantage of the magnificent views toward the sea and of the hills of Sintra. The facade is composed by the stacking of several concrete slabs with eight different sizes. The stacking is done so as to leave some empty spaces along the facade, which are the main aesthetic characteristic of this project (Fig.7.6).



Fig.7.6 - An image of the facade, where it is visible the concrete slabs with different sizes and the produced empty spaces (source: <http://guedescruzarquitecto.wix.com/pt>)

Now, we will start to classify this project's facade. The geometry of the facade is regular and we classify it as Straight. As we already mentioned, this project's facade is composed by slabs made of concrete, so we classify this facade as Concrete according to the Material and Color dimension.

As the concrete slabs constitute the facade's surface, we consider them as the facade's elements. Their geometry is rectangular, which means we classify them as Rectangular relatively to the Element's Geometry dimension. The size of the slabs varies between eight possible dimensions and, this variation seems to have no apparent rule. We classify these elements type of size variation as Random Size.

The distribution of the elements (the slabs) does not follow any rule and it creates random empty spaces. We classify this facade type of distribution as Random-Grid. The articulation of the surface is made through the stacking of concrete slabs and it is classified as Stacked.

EXAMPLE 5 QUALITY HOTEL FRIENDS, SWEDEN

This hotel is a project of Karolina Keyzer and Wingardhs Architects and it was constructed in 2013. The hotel facade is composed by several circular windows (Fig.7.7), which together create an illusion similar to a wave. This wave illusion is produced by three types of windows with different sizes — 1.4m, 1.7m and 2m in diameter — and it starts from a point located in the northern facade, more precisely in its left-top.

We can classify this building's facade as Concrete relatively to the dimension Material and Color. According to the Facade's Geometry dimension, this facade is classified as Straight.

We consider the elements as the circular windows and, according to the Element's Geometry dimension, these elements are classified as Circular. The geometry of these hotel windows does not suffer any deformation, even though their size varies according to the distance to a point. We classify the type of size variation of the elements as Attracted.

The distribution of the windows is made in two directions, width and height, which corresponds to the subgroup of 2D distribution. As the elements are aligned vertically and horizontally with each other, this facade's type of elements distribution is classified as Regular-Grid.

Finally, the articulation between the surface and its elements is made by the subtraction of the elements from the facade's surface. We classify this facade type of articulation as Perforated.

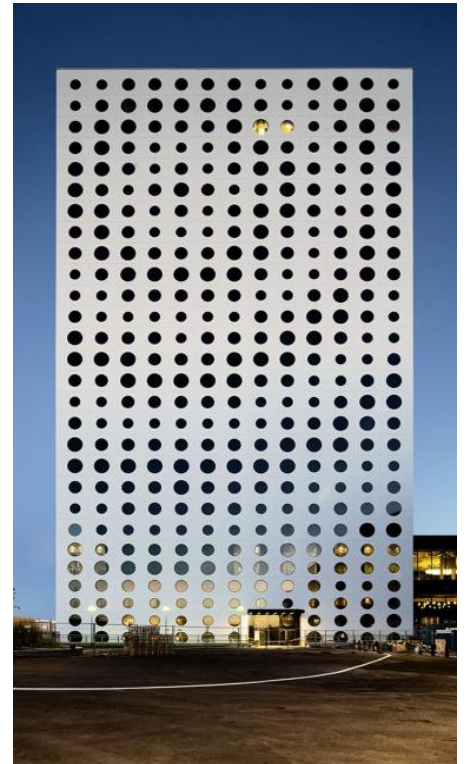

Fig.7.7 - Photography of the Quality Hotel Friends in Sweden (source: www.archdaily.com)

EXAMPLE 6 SUZHOU SND DISTRICT URBAN PLANNING EXHIBITION HALL, CHINA



Fig.7.8 - Photography of the Suzhou SND District Urban Planning Exhibition Hall in China (source: <http://www.archdaily.com/>)

The Suzhou Planning and Exhibition Hall (Fig.7.8) was designed by the studio BDP and it dates to the summer of 2013. It was built within the Science and Technology Smart City and it sits on the edge of a new central parkland area, with a marvelous view of the surrounding landscape. The cylindrical building curves upwards in a spiral movement, in order to integrate into the surrounding parkland, and it terminates in a roof top garden. The facade is composed by several metallic blades placed in parallel to each other, thereby creating a permeable facade with the outside. At night the building has spectacular lighting effects, which form a central point to the parkland and lakeside.

Now, we will start to classify the facade of this building. As the shape of the building is cylindrical, its facade has also the same shape, being classified as Cylindrical.

We considered that the metallic blades are the facade elements. In relation to the Element's Geometry dimension, the elements are classified as Stripes. As we can see in the picture above, all blades have the same size (width and length) but they are distorted around their central axis. We classified the blades as Fixed, in relation to the Element's Size dimension, and as Twisted towards the dimension Element's Distortion.

Regarding the Element's Distribution dimension, the blades are placed right next to each other with a fixed distance. As these elements are continuous along the facade's height (the blades start from the facade's base and end at its top), they only need a point to be placed, which corresponds to the subgroup of distributions in 1D. The blades are placed vertically, which means their distribution is in columns. As the elements in the even columns have a different rotation than the ones in the odd columns, we classified this type of element's distribution as Alternated Columns. Relatively to the Element's Rotation dimension, we have already mentioned that the blades are rotated horizontally, which means we classify them as Horizontally Rotated.

Lastly, the articulation of this facade is made through the juxtaposition of the metallic blades and it is classified as Juxtaposed. As the blades are made by metal, this facade is classified as Metal in the Material and Color dimension.

EXAMPLE 7 UTRECHT UNIVERSITY LIBRARY, NETHERLANDS

The Utrecht University Library (Fig.7.9) was designed by the Dutch studio Wiel Arets Architects and it was constructed in the year of 2004. The exterior skin of this building is a combination of treated glass and a few concrete panels. The glass panels were printed with a custom frit-pattern inspired in the image of a papyrus plant. The choice of papyrus was based not only on its relation with the traditional paper production, as also on the derived etymology from Greek *byblos*, i.e. library. The sequence of printed glass panels allows the surface to perform as a curtain that veils the library, while also masking subtle allusion to the nature of the program within.

Regarding the classification of this facade, we classify it as Glass in the Material and Color dimensions, and as Straight in the Facade's Geometry dimension.

This project's skin is composed by several glass panels with shadows of papyrus plant. We consider the papyrus plants panels as the facade elements and we classify them as Pictorial in the Element's Geometry dimension. The

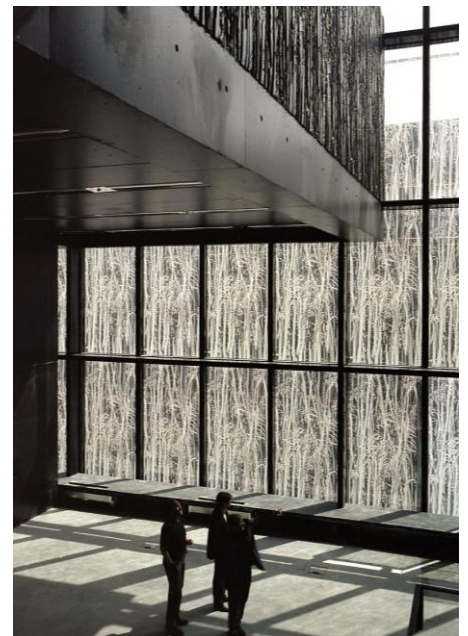

Fig.7.9 - Photography of Utrecht University Library (source: www.archdaily.com)

panels do not suffer any deformation nor size variation, being classified as Fixed in the Element's Size dimension.

The type of elements distribution requires two points for placing them, which means it is a distribution in 2D. The glass panels are placed in a Regular-Grid, i.e. vertically and horizontally aligned with each others.

We classify this facade's type of articulation as Printed, because the stamps of papyrus plants are printed on this library's surface.

EXAMPLE 8 LOUIS VUITTON STORE, JAPAN



Fig.7.10 - Image of Louis Vuitton Shop in Tokyo (source: www.dezeen.com)

Japanese studio Aoki Jun and Associates redesigned the facade of the Louis Vuitton store in the Ginza district of Tokyo (Fig.7.10), in 2013. The facade is patterned and perforated based on both brand's monogram and on the history of Ginza, the city that used to be known for its art deco design. The perforated panels mask the steel-framed reinforced concrete structure of the building beneath. The pattern used on the store's facade reveals various appearances in sunlight and also during night, as with LED light behind the reliefs the facade gets another expression.

The double skin of the Louis Vuitton Store is made of metal, being classified as Metal in the Material and Color dimension. The shape of the double skin is regular, being classified as Straight.

The outer skin is composed by several diamond-shaped squares, i.e. squares with rounded edges, which are classified as Pictorial in the Element's Geometry dimension. The size of the elements varies according to the distance to a horizontal line, which is placed almost in the centre of the facade (aligned with the Louis Vuitton sign). We classify this type of size variation as Attracted Size.

Regarding the Element's Distribution dimension, the elements are distributed in a Recursive-Grid, being classified with the same name. The facade's articulation is made through the overlapping of two layers, so we classify this building's skin as Layered in relation to the Facade's Articulation dimension. The outer layer has a Juxtaposed type of articulation (because the union of

the diamond-shaped squares compose the whole surface), while the other layer is just plain with some focus of LED lights.

7.1.2 ANALYSIS OF THE PRACTICAL EXAMPLES

In this chapter, we have classified the facade of eight different projects using our categorical dimensions. This classification of facades can be applied to several types of facades designs, covering a wide range of design ideas. Note that the practical examples, here developed, aim to clarify the correct application of our classification in any type of facade design. The classifications of the projects analyzed in this chapter, are summarized in the table.7.1 (below).







DIMENSION	FAÇADE GEOMETRY	ELEMENT GEOMETRY	ELEMENT DEFORM.	ELEMENT SIZE	ELEM. DISTRIBU.	ELEMENT ROTATI.	FAÇADE ARTICULA.	MATERIAL/ COLOR
	STRAIGHT	HEXAGONAL	—	ATTRACTED	ALTERNATED GRID	—	PERFORATED	METAL
	UNDULATED	STRIPES	—	FIXED	COLUMNS	—	JUSTAPOSED	METAL
	STRAIGHT	RECTANGULAR	—	FIXED	ALTERNATED GRID	PICTORIAL	STACKED	MASONRY
	STRAIGHT	RECTANGULAR	—	RANDOM	RANDOM GRID	—	STACKED	CONCRETE
	STRAIGHT	CIRCULAR	—	ATTRACTED	REGULAR GRID	—	PERFORATED	CONCRETE
	CYLINDRICAL	STRIPES	TWISTED	FIXED	ALTERNATED COLUMNS	HORIZON.	JUSTAPOSED	METAL
	STRAIGHT	PICTORIAL	—	FIXED	REGULAR GRID	—	PRINTED	GLASS
	STRAIGHT	PICTORIAL	—	ATTRACTED	RECURSIVE GRID	—	LAYERED: JUSTAPOSED	METAL

Table.7.2 - Synthesis of the classification of eight projects. Left column: the projects. Other columns: the dimensions and the corresponding coordinate of each project.

It should be noted that the intended use of our framework’s classification is not for existing facades, but for idealized facade designs. In practical terms, after classifying a certain facade design, the designer receives a set of functional operators, that he must then implement and combine to generate the idealized facade.

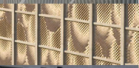
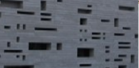
In addition, the testing of ideas is facilitated using our framework and it allows the designer to experiment, not only his design ideas, as also designs that were beyond his imagination.

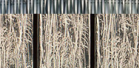
8 FACADES GENERATION PROCESS

In the previous chapter we classified several existing buildings, on which we applied the classification developed by us, which was explained in chapter 6. In this chapter we explain the process behind the generation of facades. To this end, we describe some of the strategies adopted by us in the generation of a facade model.

To make a more detailed explanation of the process, we decided to choose an existing facade to be our practical example: The Library of Birmingham, in England. Then, we generated the library's model by using the functional operators available in our framework. The library's generation process was described in four stages: (1) Analysis of the facade's design, (2) Facade's Classification, (3) Implementation of the algorithms (4) Exploration of the generated model.

8.1 ANALYSIS OF THE FACADE'S DESIGN



Fig.8.1 - Photography of the Library of Birmingham (source: www.archilovers.com/)

Located in Birmingham, UK, the Library of Birmingham is one of Europe's largest public libraries, which was design by the Dutch Studio Mecanoo and built in 2013. This library has a shimmering facade clad with interlocking metal rings of two sizes. The pattern produced by the multiple metal rings is inspired by the artesian tradition of this once industrial city and adds a filigree skin of metal rings over golden silver and glass facades.

To generate this facade, we had to decompose its design into several parts. This process helped us understand the underlying geometry and the classification that better suits this facade's design. When we look at this Library's facade, the first characteristic that we see is the overlapping of the metal rings, which originates a transparent skin. The facade's pattern is composed by two sizes of rings: the black rings and the golden rings, which are three times smaller than the black ones. To facilitate the generation process, we defined that each size of rings constitutes different facade layers. We started by analyzing the layer composed by the black rings, for which we made a scheme that helped us understand how we could generate and, then, place the rings, in order to produce a pattern equal to the real one.

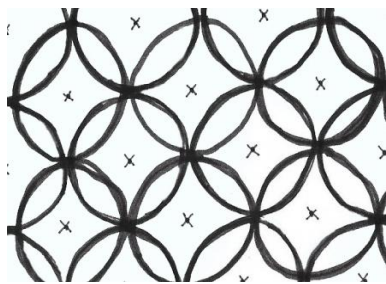

Fig.8.2 - Scheme of the facade's rings.

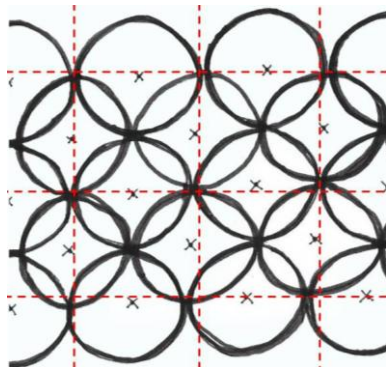

Fig.8.3 - Division of the facade's pattern into squares.

In a first analysis, we defined that the metal rings constituted the facade's elements, which were distributed according to the typology Alternated-Grid (explained in the chapter that develops the classification, chapter 6, more specifically in the section 6.2.5-Element's Distribution). Due to the fact that the facades edges finish with half-rings and quarter-rings, we had to exchange the rings for another type of element. To this end, in a second phase of analysis, we fragmented the pattern into squares defined by four points (the grid of points explained in section 6.2.5), wherein each square of the pattern constitutes one element of the facade (see Fig.8.3).

So far, we have already defined the elements: four arcs of a circle that, together, generate a design similar to a flower. Now, we need to establish how this elements' geometry is generated. To compute each element, we used an operation that produces a surface between arcs of circles. As the facade's rings have thickness and also depth, we have to subtract a surface defined by a smaller arc from a surface defined by a bigger arc to create the ring's thickness (Fig.8.5).

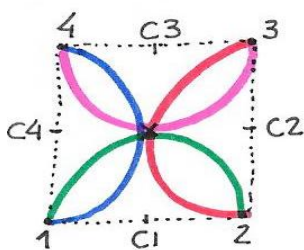

Fig.8.4 - The facade's element is composed by four arcs, which are represented in four different colors.

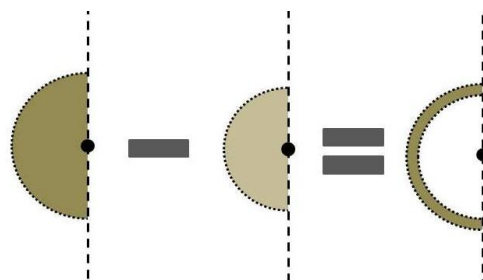

Fig.8.5 - The subtraction of two surface arcs. The left arc has a bigger radius than the middle arc. The subtraction of the middle arc from the left arc creates the arc on the right — a ring.

The subtraction of these two surfaces creates the ring's surface. For the generation of the elements, we used the grid's four points to delimit a square, in which we generated four half rings (which correspond to arcs of circle). Each ring starts and ends in two of the four points and all the rings intersect themselves in the center of the square (see Fig. 8.4). The set of rings create a visual effect similar to a flower, wherein the thickness of the rings is controlled by us.

To produce the elements depth, we had to extrude the rings along a vector perpendicular to the surface. In practical terms, we can extrude the four rings (or the elements) according to the depth value, which is also controllable and set by us (Fig. 8.6).

The black rings constitute one of the facade's layers and they are three times bigger than the golden rings, which constitute the other layer. To compute each layer, we started by generating the elements and, then, we placed them linearly along the facade's surface. For this, we had to define the facade's length and height dimensions and also the size of the rings (or the number of rings). To create both layers, we executed twice the function that produces the overlapped rings: the first function received as argument the value r (which corresponds to the radius size), while the second function received the value $r/3$. As a result, it created a superposition of two layers with different sizes of rings

To sum up, what we described in this section is our logic behind the design analysis of a facade: (1) first we divided the facade into parts, i.e. its elements; (2) then, we realized how to generate the elements and, (3) lastly, we set how the elements are distributed on the facade. In the next stage, we classify the facade's design and, in the following stage, we generate the facade's model by using the algorithms available in our framework.

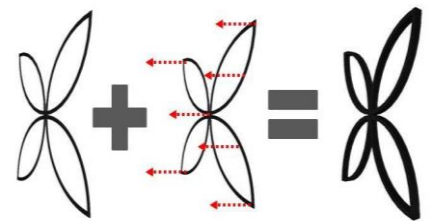

Fig. 8.6 - Scheme of an element's extrusion.

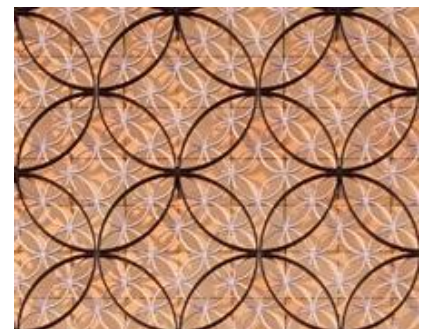

Fig. 8.7 - A photography of the facade's rings: Along the radius of a black ring, it fit three golden rings (source: www.archilovers.com/)

8.2 FACADE'S CLASSIFICATION

The Library's facade is completely regular and it is composed by a superposition of three layers: two layers of rings and a third layer with a flat surface. In the previous section we analyzed the facade's design and we concluded that the elements are composed by a set of four half rings. Our classification has available functions to generate elements with round geometry, however, as this is a more specific case of geometry, we decided to classify these elements as Pictorial. In practical terms, the elements were implemented by us, using the strategy explained in the previous section. The size of the elements does not vary and they do not suffer any deformation as well, which means we only have to be concerned about the next phase — the distribution of the elements.

When we divided the facade into a regular grid of squares, we concluded that the elements are placed aligned with each other (see Fig.8.3). Our classification has available a function to perform this type of distribution (*regularGrid*) and it receives as an argument the function *element*, which generates the elements.

Finally, this facade is composed by several different materials: The bigger rings are made of black metal, the smaller rings of golden metal and the flat plans (the facade's third layer) are made of glass and golden metal.

These classifications, which characterize this facade design, provide a set of functional operators suitable for what we want to produce. In this section we classified the design of the library's facade, while in the following section we combine the functions provided by the classification to generate the final model.

8.3 IMPLEMENTATION OF THE ALGORITHMS

In the previous section we classified the facade of the Library of Birmingham and, in this section, we will generate its model by applying the functional operators provided by the classification.

FACADE'S GEOMETRY	ELEMENTS GEOMETRY	ELEMENTS DISTRIBUTION	FACADE'S ARTICULATION	MATERIAL AND COLOR
STRAIGHT		REGULAR-GRID	LAYERED	BLACK AND GOLDEN METALS AND GLASS

The facade's geometry is Straight and, to produce this type of surface we received the function *StraightGeometry*. This function produces a parametric surface with a regular geometry, whose dimensions (length and height) are controlled by us. The geometry of the elements was classified as Pictorial, which means we had to implement the function that generates the elements' shape.

The following step was distributing the elements on the facade's surface. This type of element's distribution was classified as Regular-Grid, which provides a function that produces a regular distribution of the elements — the function *regularGrid*. This function receives two functions as arguments, while as result it produces a layer of overlapped rings (see Fig.8.9):

1. The function that generates the facade's type of geometry – *StraightGeometry*;
2. The function that generates the elements – *elements*.

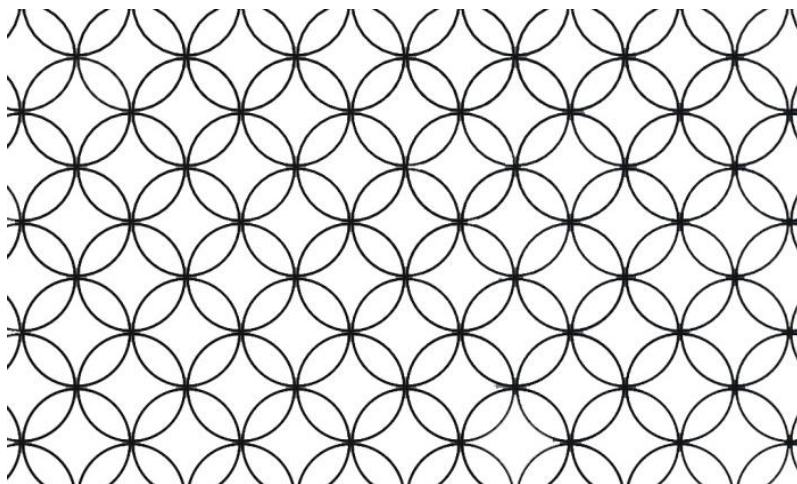

Fig.8.8 - A layer of overlapped rings.

The Articulation of this facade was classified as Layered, because it is composed by an overlapping of three different layers: two layers with a grid of rings and one layer with a planar surface. This type of articulation provides a set of algorithms, which executes more than one function at the same time. Each function corresponds to a different layer and, as this example is composed by three layers, the function *Layered* receives three functions as arguments:

1. One function that generates the layer with the bigger rings made of black metal;
2. One function that generates the layer with the smaller rings made of golden metal;
3. One function that produces a regular surface with straight geometry.

The combination and the implementation of the previous functions generates the whole model of the Library of Birmingham.

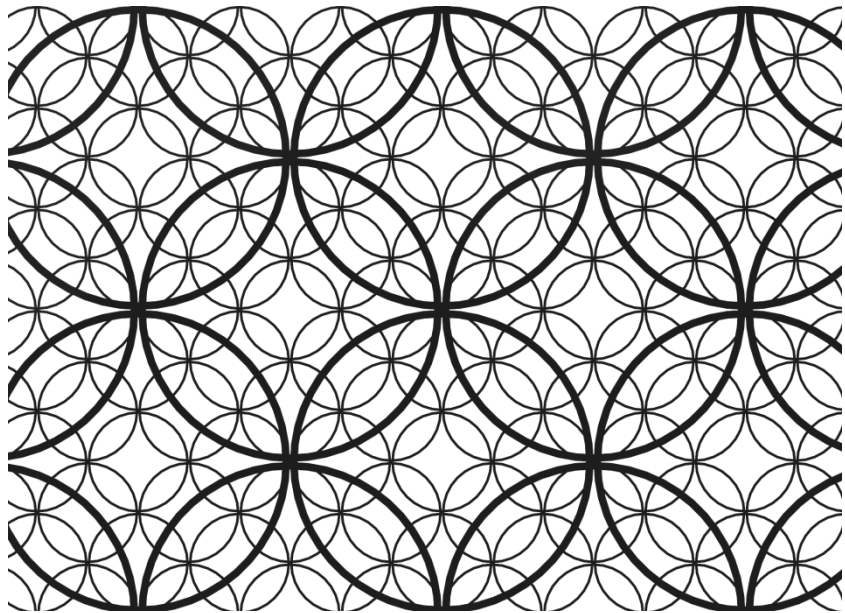

Fig.8.9 - The overlapping of the two layers of rings.

8.4 MODEL EXPLORATION

In the previous section, we combined the provided algorithms to create the function that generates the Library's facade. In this section, we start by generating a small model of the Library of Birmingham, on which we take advantage of the parametric approach (more precisely, the algorithmic approach) in the exploration of a design. This approach has the ability to control the design change, such as the increasing or decreasing of the size of certain parts of the model, without any additional effort.

To generate the Library's model, we started by defining the points on which the function that generates the facade pattern operates. Based on the geometry of the real Library, we set the relations between the model volumes and we defined a unique function to generate the whole library, depending on the values given to the parameters — function *LibraryBirmingham*.

The Library was divided into three main volumes with rectangular geometry, placed on the top of each others: the largest volume is placed below the other two and, the smallest volume is placed at the top of the model. In addition, we added a ground volume with rectangular shape and also a cylindrical volume at the top of the library's model (Fig.8.11).

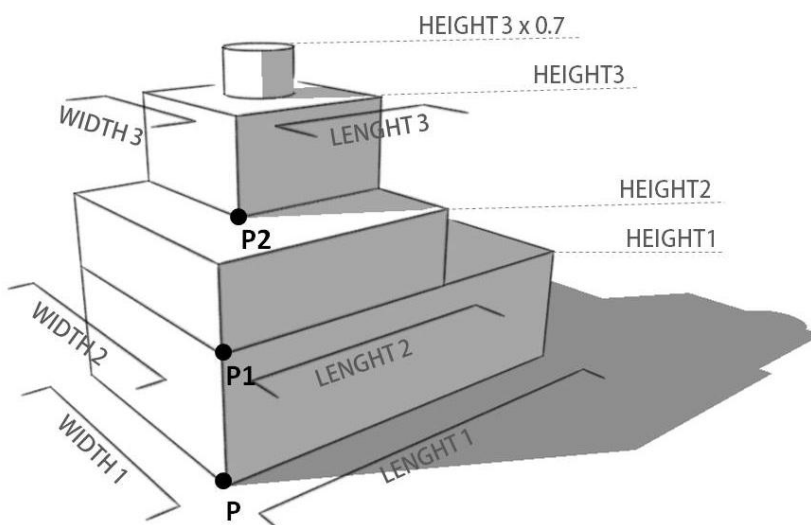

Fig.8.11 - The model's structure: the definition of the main volumes, points (*P*, *P1* and *P2*) and the function's parameters — *length*, *width* and *height*.

The library's three main volumes are wrapped by the metal rings pattern, which means the function that generates the metal rings skin is produced at

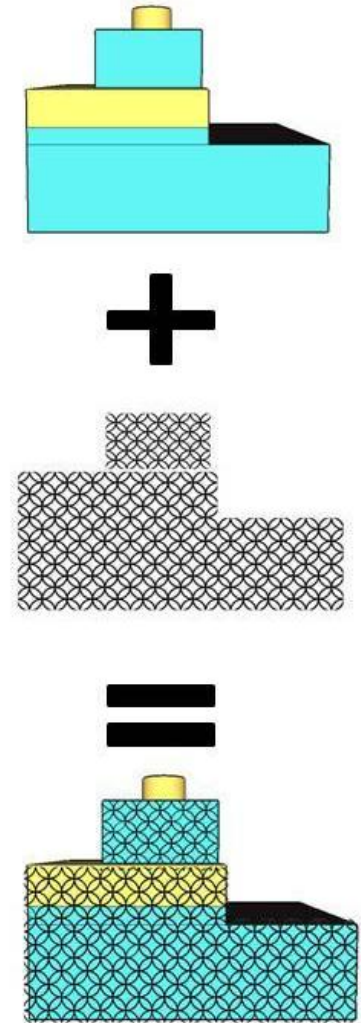

Fig.8.10 - Example of the production of the Library's model with the different layers.

each volume's vertical faces (Fig.8.10): it corresponds to 4x3 surfaces, i.e. 12 surfaces covered by the metal rings pattern.

After defining the library's model, we can test several different possibilities around the same design principle, which includes varying the radius of the rings, varying the thickness of the rings, varying the library's dimensions, etc. These changes are controlled by the dependencies between the design parts, allowing the entire model to follow the changes without deforming.

The function *Library* receives a set of independent parameters, such as the Library's heights values ($height_1$, $height_2$ and $height_3$), each volume length and width dimensions ($length_1$, $length_2$, $length_3$, $width_1$, $width_2$ and $width_3$) and the black rings' radius size. Automatically, the golden rings are generated with a size three times smaller than the value given to the parameter *radius*.

The *Library's* parameters can receive different values as arguments, generating different models as result (the generated model depends on the values given to the parameters). As a practical example, imagine we select a first set of parameters to perform the function *Library*, which corresponds to the values in the table below:

LENGTH ₁	WIDTH ₁	HEIGHT ₁	LENGTH ₂	WIDTH ₂	HEIGHT ₂	LENGTH ₃	WIDTH ₃	HEIGHT ₃	RADIUS
120M	150M	50M	120M	120M	60M	90M	90M	30M	10M

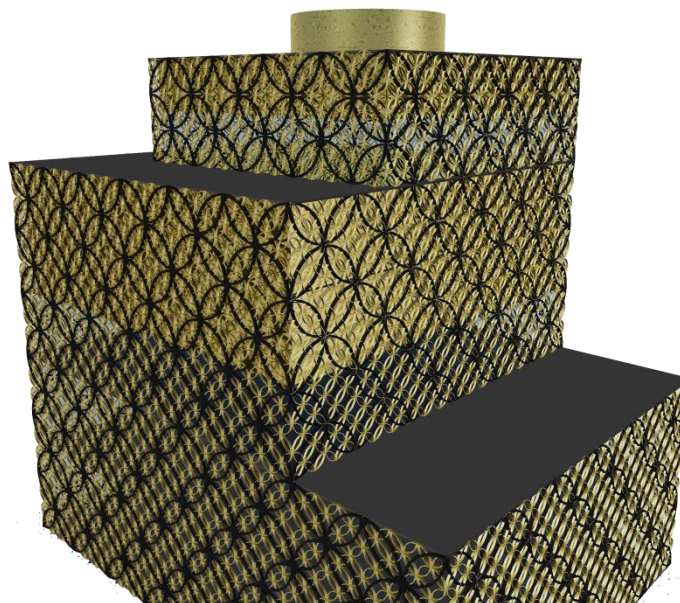

Fig.8.12 - The Library's Model : generated with the first set of parameters (table above).

The Fig.8.12 shows the model generated by the function *Library*, which has the characteristics and proportions according to the chosen values. In the next example, we maintain the dimensions of the model, while the parameter *radius* receives a higher value: radius=15 meters. As a result, the model keeps the same dimensions as the previous example, while the facades pattern is now composed by larger rings (Fig.8.13). The table below shows the second set of parameters given to the function *Library*:

LENGTH ₁	WIDTH ₁	HEIGHT ₁	LENGTH ₂	WIDTH ₂	HEIGHT ₂	LENGTH ₃	WIDTH ₃	HEIGHT ₃	RADIUS
120M	150M	50M	120M	120M	60M	90M	90M	30M	15M

Then, we will continue to vary the value of the radius parameter and, this time, we increase its value to thirty: radius=30meters. We continue to maintain the other parameters' values, thereby keeping the model's dimensions (Fig.8.14). Please note that the parameter *radius* can receive any value as input, thus giving a lot of flexibility to the model. We can select a radius larger or smaller than those we gave in these examples, which produces different variations of the rings pattern.

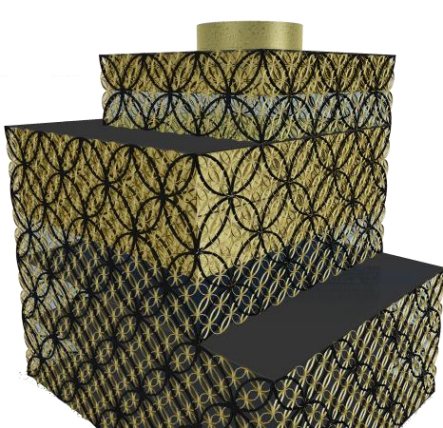

Fig.8.13 - The Library's Model : generated with the second set of parameters (radius=15m).

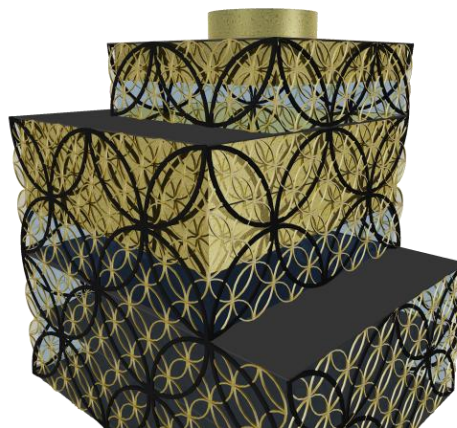

Fig.8.14- The Library's Model : generated with the third set of parameters (radius=30m).

As another example, imagine we keep the value of the radius parameter equal to 15 (radius=15m) and we change the other parameters values: the volumes' length, width and height dimensions. In this case the facade pattern suffers no variation, while the model's volumes vary their sizes and proportions.

The parameters *length*, *width* and *height* can also receive any value as input, which corresponds to different sizes. This gives enough flexibility to the model, allowing the distortion of the real library's proportions. In fact, the variation of any of the parameters produce changes in the library's model,

which are produced and controlled by the generation function. This allows the rapid visualization of several different models as result, without spending much time and with almost no effort. The table bellow shows another set of parameters with different values for all the height dimensions. The Fig.8.15 shows the resulting model.

LENGTH ₁	WIDTH ₁	HEIGHT ₁	LENGTH ₂	WIDTH ₂	HEIGHT ₂	LENGTH ₃	WIDTH ₃	HEIGHT ₃	RADIUS
120M	150M	30M	120M	120M	30M	90M	90M	15M	15M

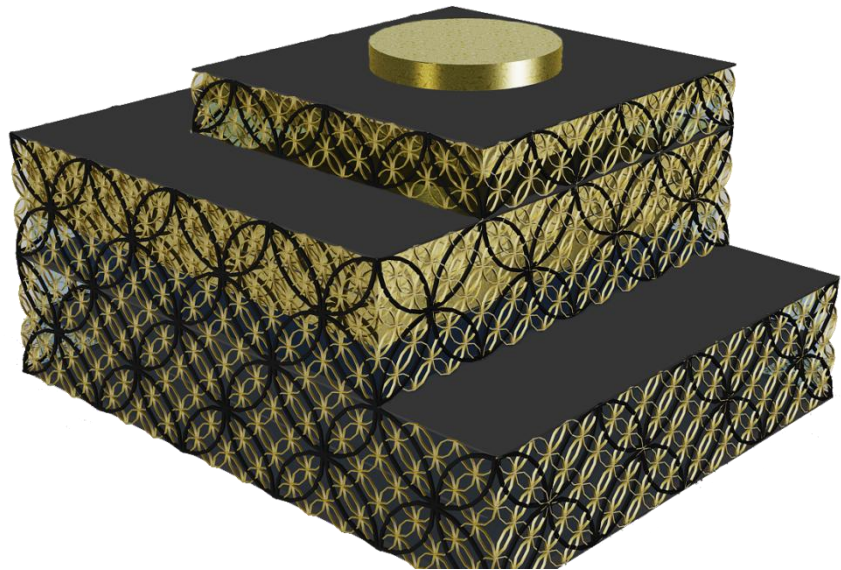

Fig.8.15 - The Library's Model: generated with the fourth set of parameters (table above).

Finally, in our last two examples, we vary the size of all the library's dimensions, including the radius size. For this, we selected two more sets with different values, which are represented in the tables below. Therefore, the generated models have different proportions and they are represented in both Fig.8.16 and Fig.8.17, respectively.

LENGTH ₁	WIDTH ₁	HEIGHT ₁	LENGTH ₂	WIDTH ₂	HEIGHT ₂	LENGTH ₃	WIDTH ₃	HEIGHT ₃	RADIUS
210M	210M	60M	180M	180M	60M	150M	150M	60M	30M

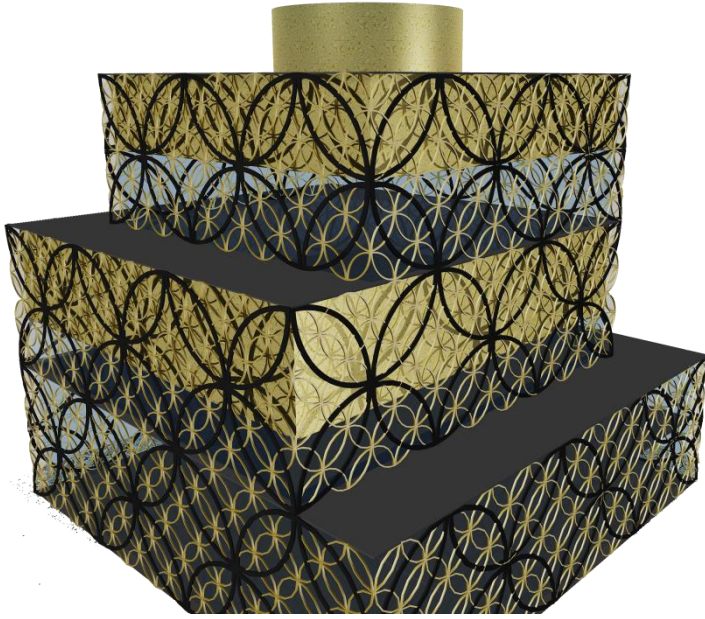

Fig.8.16 - The Library's Model: generated with the parameters summarized in the table above.

LENGTH ₁	WIDTH ₁	HEIGHT ₁	LENGTH ₂	WIDTH ₂	HEIGHT ₂	LENGTH ₃	WIDTH ₃	HEIGHT ₃	RADIUS
120M	150M	70M	120M	120M	80M	80M	80M	40M	10M

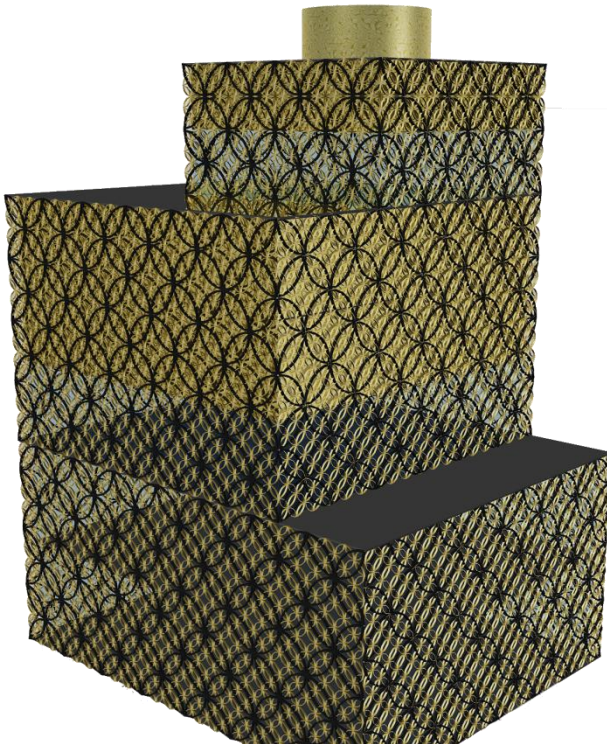

Fig.8.17 – The Library's Model generated with the set of parameters in the table above.

9 THE GENERATION OF CONTEMPORARY FACADES

In practical terms, the end result of our research is a library of functional primitives and functional operators usable in different programming languages and a set of guidelines that helps a designer to select and combine the most useful operators to implement a design for a particular facade. In this section we explain the application of this framework by performing several models as examples.

In a first stage, we generate some abstract examples to better explain the application of the provided algorithms, while showing the resulting models. In a second stage, the algorithms available in the framework are applied to generate examples that already exist, in order to obtain the models of the corresponding facades.

9.1 PRACTICAL APPLICATION

Example1 — As an example, consider we want a facade with straight geometry and with squared elements. For this, we select from the dimensions Facade's Geometry and Element's Geometry the operations which respectively correspond to a (1) straight surface and (2) squared elements. Let us also assume that we want the size of the elements to vary along the facade's length, i.e. the elements have an increasing size variation. Our framework also provides an operation, *increasingSize*, to produce this type of size variation, which is available inside the dimension Element's Size.

Given this information, we can define the function that generates each element as the functional composition of the functions that implement the selected algorithms, i.e. we combine both *squaredGeometry* and *increasingSize*.

Having the elements defined, now we move our attention to the distribution of the elements on the facade's surface. We will consider that the elements are distributed in a regular-grid and, simultaneously, with a horizontal rotation. The elements' rotation angle also increases along the facade's length as it happened with their size. To implement these considerations, we select the operation *regularGrid* from the dimension Element's Distribution, as this operation produces a regular distribution, and we select from the dimension Element's Rotation an operation that gives a rotation to the elements. To actually distribute the elements on a certain surface, we have to combine these functions with all the functions that we selected so far. The *regularGrid* function is a higher-order function, which receives other functions as argument:

1. The function ***element*** – the function *regularGrid* knows how the distribution is done but it needs to know the element to distribute;
2. The function ***straightGeometry*** – the function *regularGrid* requires the set of points on which the distribution will be done;
3. The function ***horizontalRotation*** – the function *regularGrid* needs to know if there is some kind of rotation, when distributing the elements and how the rotation is done.

Lastly, we will assume that the elements – squares – are applied on the facade's surface, which corresponds to the function *applied* in the Facade's Articulation dimension, and the materials used are glass for the surface and black metal for the elements (see Fig.9.1). For each of these classifications, we receive the most appropriate functions, which then we combine using the functional operators.

FACADE'S GEOMETRY	ELEMENT'S GEOMETRY	ELEMENT'S SIZE	ELEMENT'S DISTRIBUTION	ELEMENT'S ROTATION	ARTICULATION	MATERIALS
STRAIGHT	SQUARED	INCREASING	REGULAR GRID	HORIZONTAL	APPLIED	GLASS & BLACK METAL

Table.9.1 – Classification synthesis of the Example1

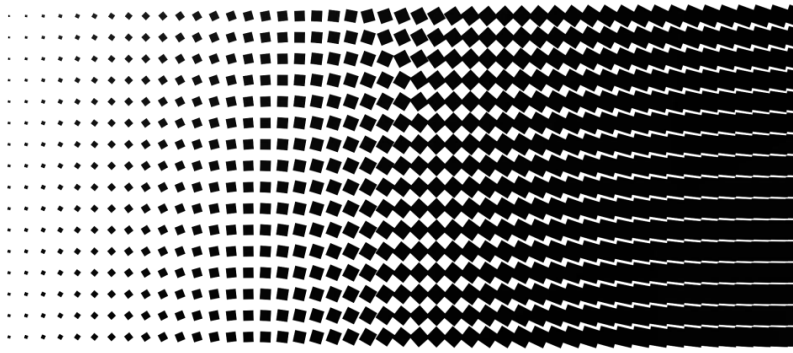

Fig.9.1 - An image of a pattern produced by the classification in the table.9.1.

Example2 — In the first example, both size variation and elements rotation vary along the facade’s length. Now, if we change the type of element's distribution to become an alternated-grid, we generate the following facade example (Fig.9.2):

FACADE'S GEOMETRY	ELEMENT'S GEOMETRY	ELEMENT'S SIZE	ELEMENT'S DISTRIBUTION	ELEMENT'S ROTATION	ARTICULATION	MATERIALS
STRAIGHT	SQUARED	INCREASING	ALTERNATED GRID	HORIZONTAL	APPLIED	GLASS & BLACK METAL

Table.9.2 – Classification synthesis of the example 2.

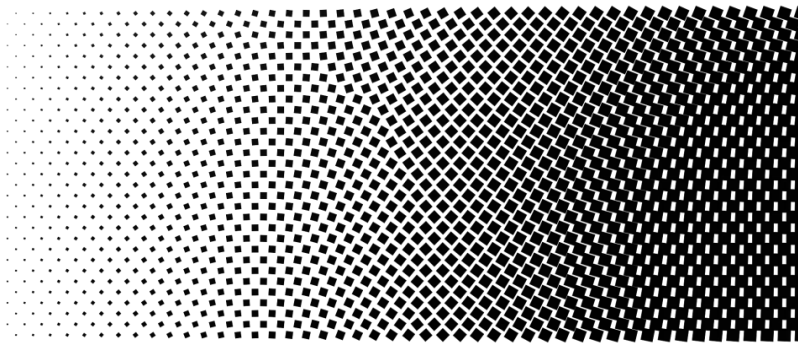

Fig.9.2 - An image of the pattern produced by the classification in the table.9.2. (with an Alternated-Grid distribution).

We could also change the distribution to become a chess-grid and the final result would also be different (Fig.9.3). These changes do not require changing the rest of the structure, which corresponds to the functions provided by the other dimensions, but simply changing the name of the function in charge of the elements’ distribution:

FACADE'S GEOMETRY	ELEMENT'S GEOMETRY	ELEMENT'S SIZE	ELEMENT'S DISTRIBUTION	ELEMENT'S ROTATION	ARTICULATION	MATERIALS
STRAIGHT	SQUARED	INCREASING	CHESS GRID	HORIZONTAL	APPLIED	GLASS & BLACK METAL

Table.9.3 – Classification synthesis of the example in Fig.9.3.

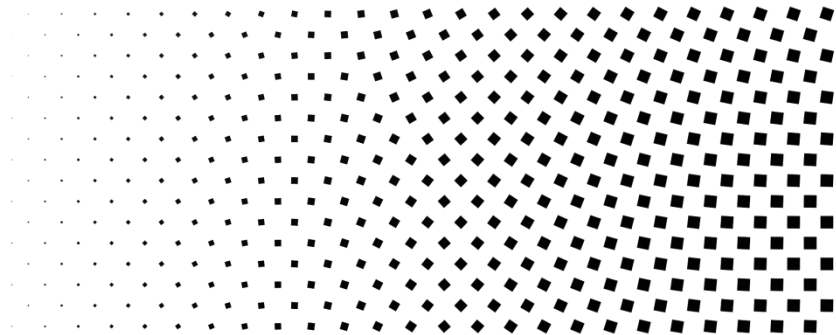

Fig.9.3 - An image of the pattern produce by the classification in the table.9.3. (with a Chess-Grid distribution).

Example3 — Now, imagine that this facade has now a pictorial size variation, which produces the image selected by us: an image with a characteristic pattern of the Portuguese stone pavement. For this, we exchange the function provided by the Element’s Size dimension, *increasingSize*, for the function *pictorialSize* and the elements – the squares - will vary their sizes according to the color intensity of the pixel that they represent (Fig.9.4).

FACADE’S GEOMETRY	ELEMENT’S GEOMETRY	ELEMENT’S SIZE	ELEMENT’S DISTRIBUTION	ELEMENT’S ROTATION	ARTICULATION	MATERIALS
STRAIGHT	SQUARED		REGULAR GRID	—	APPLIED	GLASS & BLACK METAL

Table.9.4 – Classification Synthesis of the example in Fig.9.4.

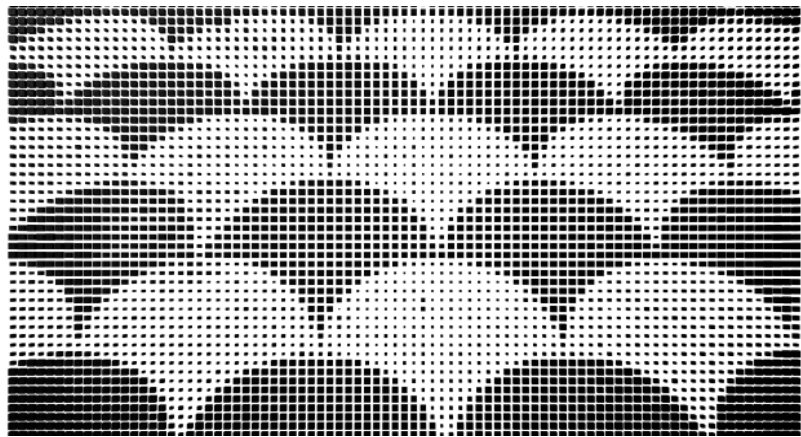

Fig.9.4 - An image of the pattern produced by the classification in the table.9.4.– with a Pictorial Size variation.

Example4 — As an example, consider an idea of a facade with Straight geometry and with Juxtaposed elements. We want the elements to have a Pictorial geometry, for which we have to provide an image, and a linearly increasing size variation. These chosen characteristics correspond to a set of functions, which together compose the function that generates the elements.

In addition, we also decide that the distribution of the elements is made in a Regular-Grid and the color of the facade is gray. For each of these classifications, we can select the appropriate function, which we will combine using the functional operators. The end result is visible in Fig.9.5 and the chosen classification is highlighted in the following Table.9.5:

FACADE'S GEOMETRY	ELEMENT'S GEOMETRY	ELEMENT'S SIZE	ELEMENT'S DISTRIBUTION	ELEMENT'S ROTATION	ARTICULATION	MATERIALS
STRAIGHT		INCREASING	REGULAR GRID	—	JUXTAPOSED	GRAY

Table.9.5 - Classification synthesis of the example4.

The HOF function that generates the facade design receives two arguments:

1. A function from the Material and Color dimension – which in this case in the color **gray**;
2. A function from the Element's Distribution dimension – which in this case is the function **regularGrid**.

Besides, the function *regularGrid* is also a Higher-Order function and it receives two functions as arguments:

1. A function from the Facade's Geometry dimension – which in this case is the function **straightGeometry**;
2. The function that generates the elements: **element**.

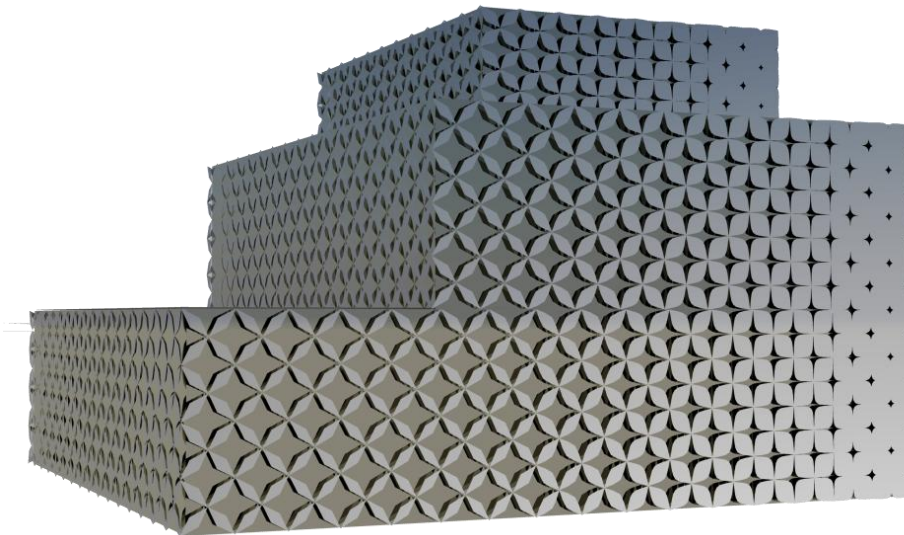

Fig.9.5 - An example of a facade generated through the framework operations: Straight facade; pictorial elements with increasing sizes; regular-grid distribution; Color gray and juxtaposed surface.

Example5 — Now, imagine we want to change the type of size variation from linearly increasing to randomized. This change seems a difficult and time consuming change using a traditional approach, since we had to change each element’s size manually and, as the facade is composed by thousands of elements, this process would be too painful. On the contrary, using this framework of algorithmic operators, this change is made simply by exchanging the operation that controls the elements type of size variation, which corresponds to the command *RandomSize*. This change produces the model visible in Fig.9.6.

FACADE'S GEOMETRY	ELEMENT'S GEOMETRY	ELEMENT'S SIZE	ELEMENT'S DISTRIBUTION	ELEMENT'S ROTATION	ARTICULATION	MATERIALS
STRAIGHT		RANDOM	REGULAR GRID	—	JUXTAPOSED	GRAY

Table.9.6 - Classification synthesis of the example in the Fig.9.6.

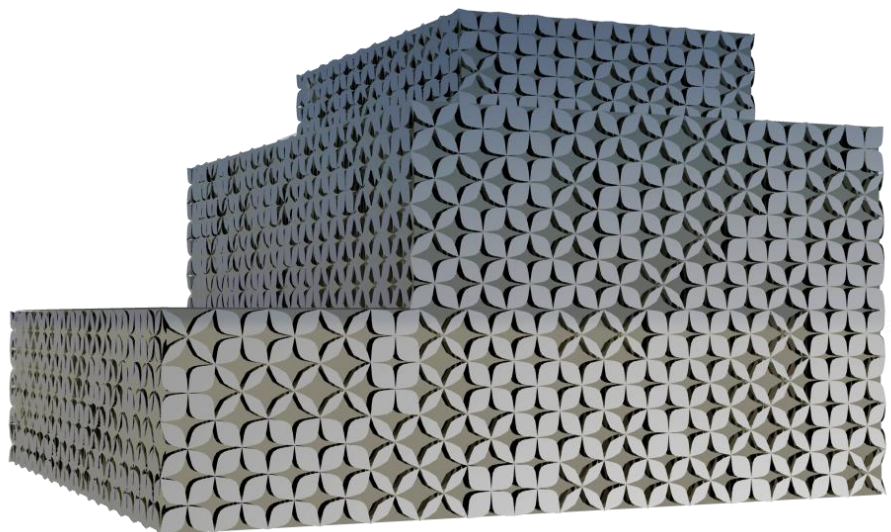

Fig.9.6 - An example of a facade generated through the framework operations: Straight facade; pictorial elements with random sizes; regular-grid distribution; Color gray and juxtaped surface.

Example6 — Now, imagine that we want a facade with the same characteristics as the previous example, i.e. a straight facade with juxtaped articulation and pictorial elements with increasing sizes. If we want to change the type of distribution in Regular-Grid by a distribution in Recursive-Grid, we just need to select the command *recursiveGrid*, instead of selecting the command *regularGrid*. The elements are, automatically, generated and placed with a different distribution than the first example, which we can see in the Fig.9.7.

FACADE'S GEOMETRY	ELEMENT'S GEOMETRY	ELEMENT'S SIZE	ELEMENT'S DISTRIBUTION	ELEMENT'S ROTATION	ARTICULATION	MATERIALS
STRAIGHT		INCREASING	RECURSIVE GRID	—	JUXTAPOSED	GRAY

Table.9.7 - Classification Synthesis of the Example3.

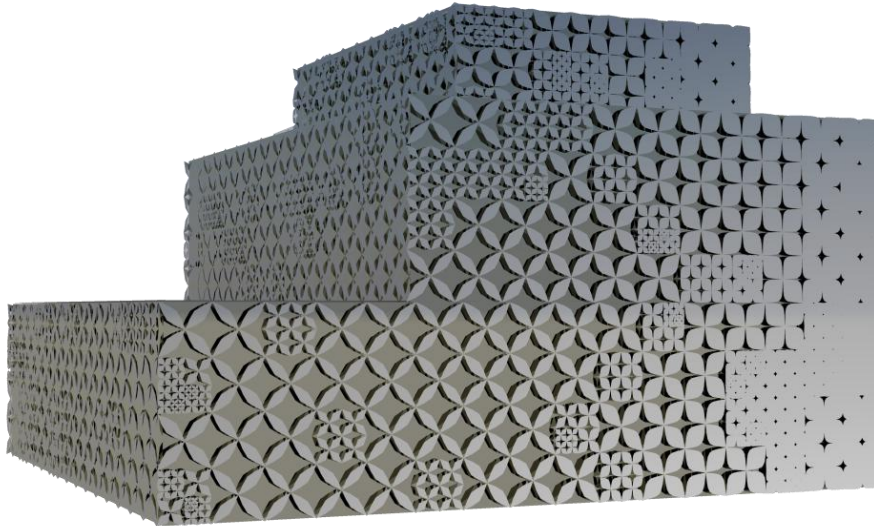

Fig.9.7 - An example of a facade generated through the framework operations: Straight facade; pictorial elements with increasing sizes; recursive-grid distribution; Color gray and juxtaposed surface.

Example7 — Imagine the facade has now the distribution of the elements in a chess-grid, but keeps the geometry and the size variation of the elements as in the previous example. In addition, the facade's articulation is now classified as Juxtaposed but also as Layered. Both layers are composed by juxtaposed elements, where the first layer is classified by the color Black and the second layer by the color Gray.

In relation to the number of elements, we define that the first layer has more elements than the second layer, which means these elements have a smaller size than the elements belonging to the second layer.

After exploring the pattern for this example, we decide to apply it on a surface with undulated geometry. The Table.9.8 organizes the classifications of this design and the Fig.9.8 shows the generated model.

FACADE'S GEOMETRY	ELEMENT'S GEOMETRY	ELEMENT'S SIZE	ELEMENT'S DISTRIBUTION	ELEMENT'S ROTATION	ARTICULATION	MATERIALS
UNDULATED		INCREASING	CHESS GRID	—	LAYERED: 1) JUXTAPOSED 2) JUXTAPOSED	1) GRAY 2) BLACK

Table.9.8 - Classification Synthesis of the Example4.

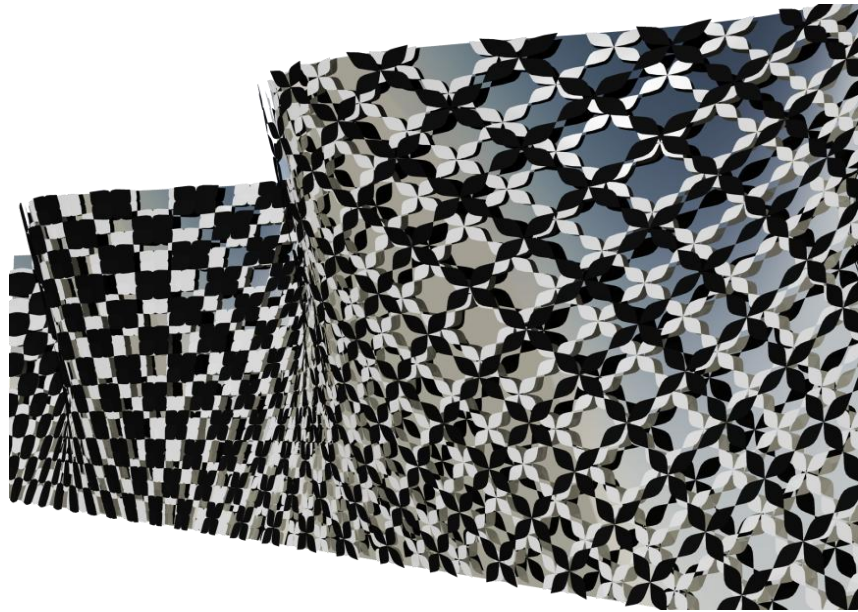

Fig.9.8 - An example of a facade generated through the framework operations: Layered facade with undulated geometry, where each layer is composed by a juxtaposed surface; pictorial elements with increasing sizes; chess-grid distribution; Color black for the first layer and gray for the second.

Example8 — Now, we want to generate a different facade design, which is also composed by elements with a Pictorial geometry, but with a different design. For this, we chose a geometry similar to a diamond-shaped square, which we have to implement via an additional algorithmic development.

We maintain all the other classifications as in the Example1, i.e. a straight facade with gray color, an articulation made by juxtaposition and pictorial elements with increasing sizes, except the type of elements distribution, which we exchange for a distribution in chess-grid. Therefore, the algorithms selected and used to generate this example8 remain the same as in the previous example4 (Fig.9.5), with the exception of the *chessGrid* function. Still, the end result of this example differs greatly from the example4, as it is visible in the Fig.9.9. The corresponding classifications are organized in Table.9.9.

FACADE'S GEOMETRY	ELEMENT'S GEOMETRY	ELEMENT'S SIZE	ELEMENT'S DISTRIBUTION	ELEMENT'S ROTATION	ARTICULATION	MATERIALS
STRAIGHT		INCREASING	CHESS GRID	—	JUXTAPOSED	GRAY

Table.9.9 - Classification synthesis of the example in Fig.9.8.

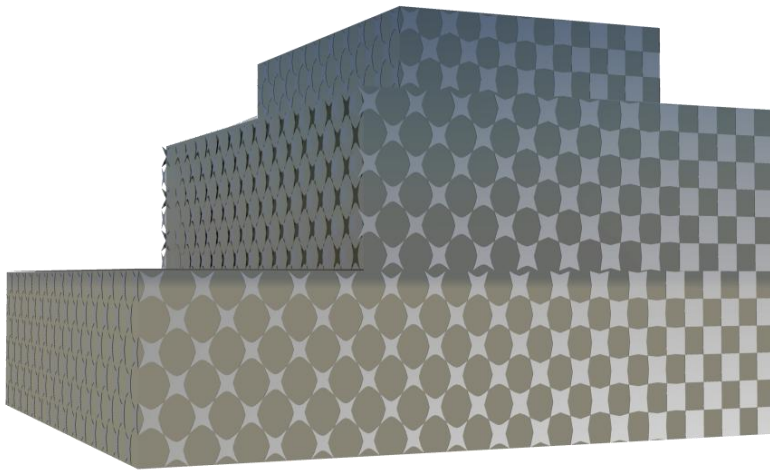

Fig.9.9 - An example of a facade generated through the framework operations: Straight facade; pictorial elements with increasing sizes; chess-grid distribution; Color gray and juxtaposed surface.

Example9 — Imagine we want to remake the model in the example7 (see Fig.9.8), the layered facade with undulated geometry, but this time using the pattern explored in the previous example (Fig.9.9). The selection and combination of the algorithms is exactly the same as in the example7, differing only the function *pictorialSize*, which defines the shape of the elements. The example in Fig.9.10 corresponds to the generated model, while its classifications are synthesized in the Table 9.9.

FACADE'S GEOMETRY	ELEMENT'S GEOMETRY	ELEMENT'S SIZE	ELEMENT'S DISTRIBUTION	ELEMENT'S ROTATION	ARTICULATION	MATERIALS
UNDULATED		INCREASING	CHESS GRID	—	LAYERED: 1) JUXTAPOSED 2) JUXTAPOSED	1) GRAY 2) BLACK

Table.9.10 - Classification synthesis of the example in Fig.9.9.

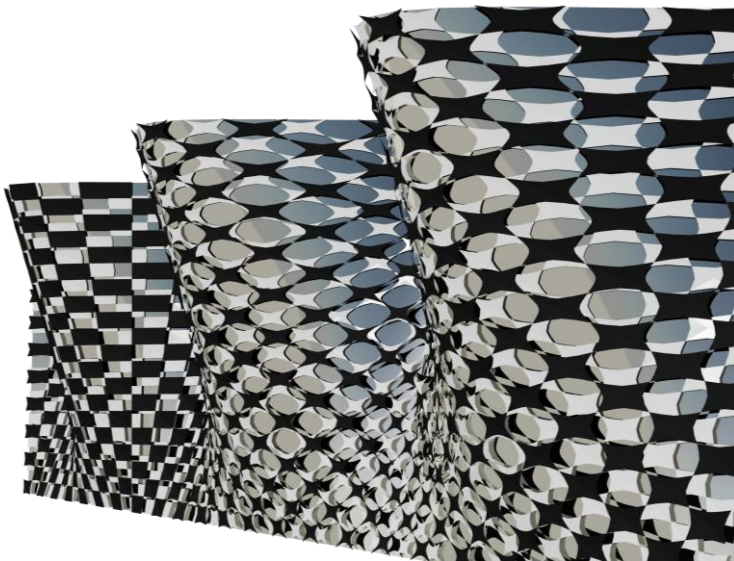

Fig.9.10 - An example of a facade generated through the framework operations: Layered facade with undulated geometry, where each layer is composed by a juxtaposed surface; pictorial elements with increasing sizes; chess-grid distribution; Color black for the first layer and gray for the second.

This developed pattern can be applied in several facades with different geometries. To change the facade's type of geometry, we simply have to select the geometry on which we want to apply the pattern. After selecting the type of geometry, the pattern is automatically applied on a surface with the selected shape.

The images below show two examples of this pattern application. The image on the left shows the application of the pattern on a cylindrical surface, while the image on the right has the pattern applied on a horizontally undulated surface. In both examples, we combine the same set of functional operators as in the previous example (see Fig.9.10), except the function that describes the facade's geometry: in the left example, the classification of the facade's geometry was changed from undulated to cylindrical (Fig.9.11) and, in the image on the right, it was changed from undulated to horizontally undulated (Fig.9.12).

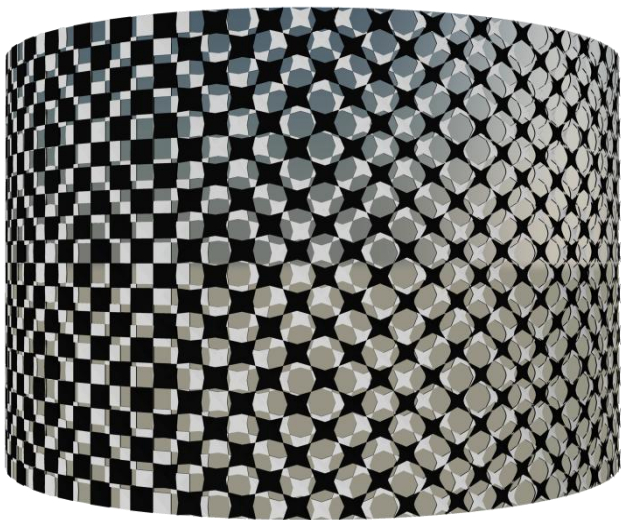

Fig.9.11 - An example of the pattern application on a cylindrical surface.

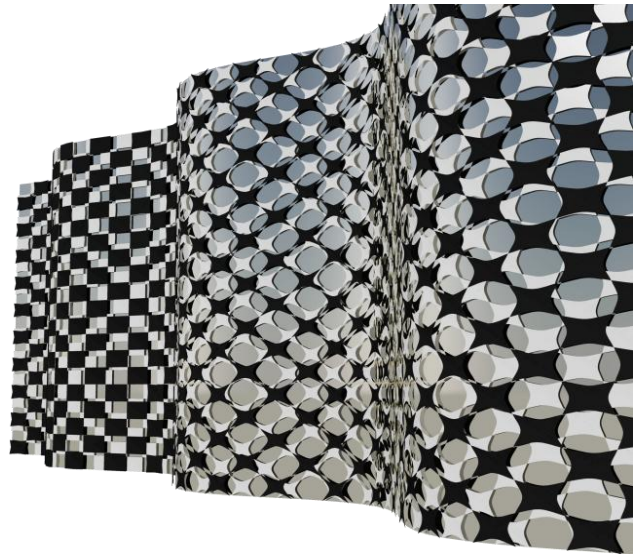

Fig.9.12 - An example of the pattern application on a horizontally undulated surface.

9.2 THE APPLICATION ON REAL FACADES

In this section, we apply the functional operators available in this framework to generate some existing facades. Depending on the characteristics of each facade, we combine the most appropriate functions to generate a model similar to the real one, on which we apply several possible variations. The main objectives are:

- (1) proving that our framework is capable of producing real facades by achieving a high degree of fidelity;
- (2) showing that we can easily generate and change models using our framework.

We start to develop the **Quality Hotel Friends** example and we follow with a similar example, the **Campus Netzwerk Office**. Then, we develop the **House AAG** example, followed by the facades of **Gantenbein Vineyard** and **FACIM WaterFront** examples.

9.2.1 QUALITY HOTEL FRIENDS, SWEDEN

Located in the city of Solna, Sweden, this hotel incorporates 400 rooms and was built near the Friend's Arena and the upcoming Mall of Scandinavia. This hotel's facade creates an illusion that looks like a set of waves starting from a point located in the facade's top-left. This illusion is produced by the hotel's windows, which have a circular shape with three different possible sizes. Therefore, depending on their sizes, the windows are strategically placed to produce the waving effect.

This facade was already classified in charter 7 and the table below summarizes its corresponding classifications:

DIMENSION	FACADE GEOMETRY	ELEMENT GEOMETRY	ELEMENT SIZE	ELEM. DISTRIBU.	FACADE ARTICULA.	MATERIAL / COLOR
	STRAIGHT	CIRCULAR	ATTRACTED	REGULAR GRID	PERFORATED	CONCRETE

These classifications provide the most suitable algorithms to generate the hotel's facade. In this section we combine and implement the selected algorithms to, first, generate the model and, then, explore some possible variations of the original design.

The function provided by the Facade's Geometry dimension produces a parametric surface with straight geometry, which height and length dimensions are defined by us: we select for this facade a length of 45 meters and a height of 75 meters (Fig.9.13).

The following step is defining the elements that constitute the hotel's facade, which in this case are the circular windows. The function provided by the Element's Geometry dimension gives shape to the windows, while the function received by the Element's Size dimension controls their sizes. Thereby, we receive two functions, one that generates circular elements – *circularGeometry* - and the other varies their sizes according to the distance to a point – *attractedSize*. In order to generate a function capable of producing the facade elements (a function *element*) we have to combine these two functions together.

So far, we define the facade's surface and the function *element* to produce the elements. In addition, we must also implement the elements type of distribution, for which we received a function capable of mapping the elements in a Regular-grid. This Higher-Order Function receives other two functions as arguments:

- 1) The function ***element*** - which generates the elements that are going to be distributed;
- 2) The function ***StraightGeometry***, which defines the geometry of the surface on which the elements are mapped (Fig.9.13).

Moreover, the function *regularGrid* also receives the number of elements to produce horizontally (n) and vertically (m), for which we choose thirteen and twenty-five elements, respectively (see Fig.9.14)

Continuing with the design implementation, the classification tells us that the hotel's facade has a relation of subtraction between its parts. This means that the circular elements correspond to the facade's holes and, indeed they correspond to the hotel's windows. As we have to subtract the elements

from the hotel's surface, we have to change the circular geometry by a cylindrical geometry in order to make the subtraction of the elements from the facade's surface (for which the elements have to be solids instead of surfaces).

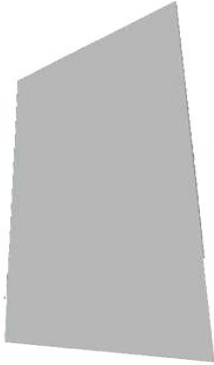

Fig.9.13 - An example of the model produced by the function *surfaceGeometry*.

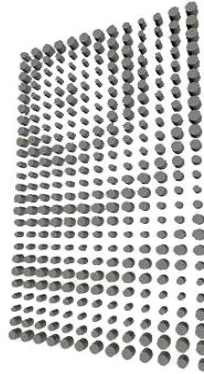

Fig.9.14 - An example of the model produced by the function *regularGrid*.

The function provided by the Facade's Articulation dimension receives two arguments: (1) the list of the elements already distributed and (2) the surface from which they are subtracted. As a result, when the solids are subtracted from the surface, they create and shape the facade perforations (Fig.9.15).

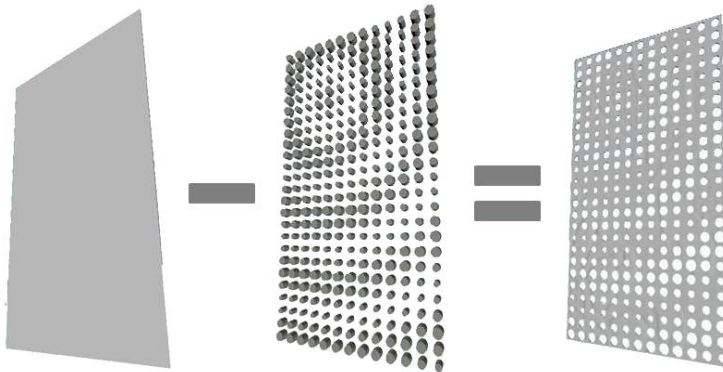

Fig.9.15 - Synthesis of the generation process of the Quality Hotel Friends' facade: The subtraction of the elements (middle image) from the facade's surface (image on the left) generates the final model of the Quality Hotel Friends (image on the right).

It is now possible to generate this hotel's model, since we have already combined all the functions provided by the classifications. The last step is selecting the Attractor point, which controls the windows size, and, based on the location of the real attractor, we selected the point (15 0 60).

So far, we explained how to use the commands available in our framework and how the generation process occurs. In the next sections, we explore different variations of this facade design, simply by changing the values of some parameters.



Fig.9.16 - An example of the Quality Hotel Friends facade produced by us: with 13X25 windows, the attractor point is (15 0 60) and the magnitude is 4.

HOTEL1 – Now, imagine the attractor point is changed to another point in the facade, the number of windows is increased or decreased, or the magnitude intensity of the waving effect is changed by another value. All of these parameters can be changed by us, receiving any value as input and producing many possible design variations.

First, we start by varying the number of windows which compose the facade. Fig.9.16 (above) shows an image of the hotel's facade with 13X25 windows. If we change the value $n=13$ by $n=20$ and the value $m=25$ by $m=37$, we create a facade similar to the one in Fig.9.16, but with more windows (see Fig.9.17). We can further increase the number of windows that compose the facade, by selecting bigger values for the n and m values and, otherwise, we can also decrease their number in both directions (n and m values). These variations of the n and m values produce automatic changes to the generated model, which are always adjusted to the design principle, without deforming the overall model and without unbalancing the distribution of the elements.

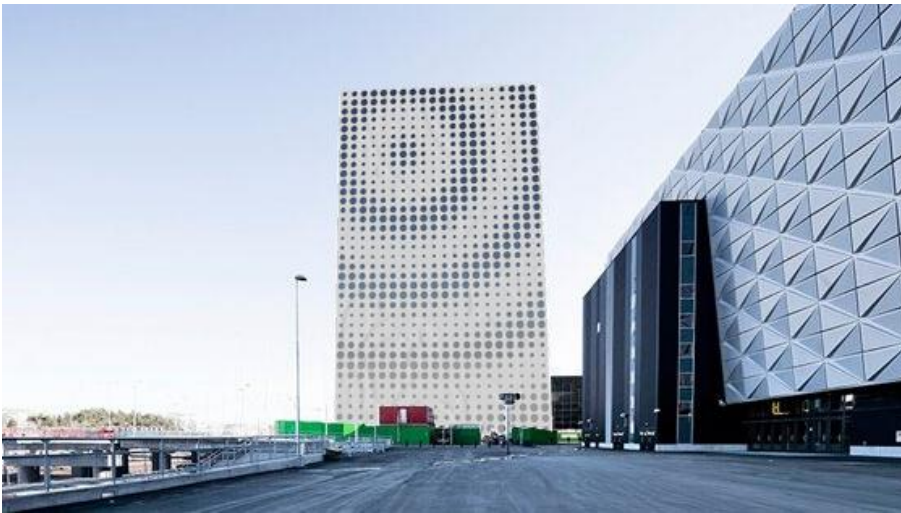

Fig.9.17 - An example of the Quality Hotel Friends facade produced by us: with 20X37 windows, the attractor point is (15 0 60) and the magnitude is 4.

HOTEL2 – Image we vary the magnitude of the attractor point, which corresponds to its power of attraction. Note that high magnitudes produce size variations with high frequencies, otherwise, low magnitudes produce size variations with a small frequencies (the size variation is softer in the same distance unit).

The facade in Fig.9.16 has its design similar to the real one and, its attractor point has a magnitude value of 4. For the next example we change the magnitude intensity by the value of 2, thus producing an effect with a waving of greater amplitude (see Fig.9.18). On the other hand, if we increase the magnitude intensity to the value of 5, the attractor's effect produces a waving of less amplitude (see Fig.9.19).



Fig.9.18 - An example of the Quality Hotel Friends facade produced by us: with 13X25 windows, the attractor point is (15 0 60) and the magnitude is 2.



Fig.9.19 - An example of the Quality Hotel Friends facade produced by us: with 13X25 windows, the attractor point is (15 0 60) and the magnitude is 5.

HOTEL3 – In our last example, we change the location of the attractor point and, consequentially, it changes the waving starting point. The attractor point of the previous examples was (15 0 60), but for generating the last two examples we change the attractor point by two different points in the surface.

For the first point we select the location (30 0 15), which originates the facade in Fig.9.20. For the second point we select the point (22 0 37), which corresponds approximately to the facade's center, and it produces the facade in Fig.9.21. In fact, the size variation of the window depends on the attractor's location and on its magnitude value. In practical terms, we only choose the attractor's location and its magnitude and, automatically, the elements size variation is controlled and adapted by the functional operators which generate this model.



Fig.9.20 - An example of the Quality Hotel Friends facade produced by us: with 13X25 windows, the attractor point is (30 0 15) and the magnitude is 4.

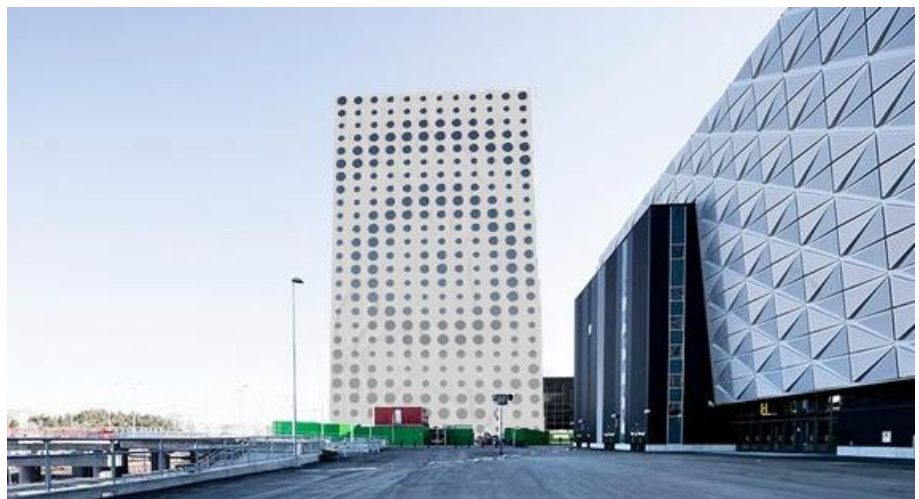



Fig.9.21 - An example of the Quality Hotel Friends facade produced by us: with 13X25 windows, the attractor point is (22 0 37) and the magnitude is 4.

9.2.2 CAMPUS NETZWERK, GERMANY

Located in Töging am Inn (Germany), this building is an office that belongs to the interdisciplinary creative campus called Netzwerk and it accommodates office spaces and meeting rooms for creative agencies. This project was designed by Format Elf Architekten and they added a pattern of hexagonal holes to the long aluminum facade to control the amount of daylight inside. The honeycomb-like pattern is parametric and it wraps around the edges of the pavilion, dissipating gradually across the end walls. We have already classified this project's facade in chapter 7, which is summarized in the table below:

DIMENSION	FAÇADE GEOMETRY	ELEMENT GEOMETRY	ELEMENT SIZE	ELEM. DISTRIBU.	FAÇADE ARTICULA.	MATERIAL / COLOR
	STRAIGHT	HEXAGONAL	ATTRACTED	ALTERNATED GRID	PERFORATED	METAL

The generation of this project follows a methodology similar to the previous example, the Quality Hotel Friends, since both facades have a Perforated Articulation. In both models, the elements are subtracted from the skin, producing the surface holes.

The implementation of the algorithms provided by the classification follows the same methodology as the previous example. For the facade's geometry, we receive a function that produces a parametric surface with straight geometry. We define its length and height dimensions as 15 meters and 4 meters, respectively. From the Element's Geometry dimension, we receive a function that generates the elements with a hexagonal shape and, from the Element's Size dimension the function *attractedSize*. The combination of these two functions produces the facade's elements, which correspond to the hexagonal perforations.

To produce the subtractions, we need the elements to be solids (with a hexagonal section) instead of surfaces, thereby the function *hexagonalGeometry* will have to produce hexagonal prisms. For the function *attractedSize*, we select the points of a line to work as attractors (see Fig.9.22): a line between the points (2.5 0 2) and (12.5 0 2).

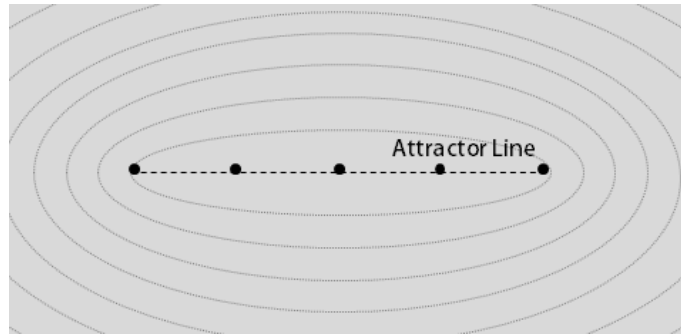

Fig.9.22 – The attractor line points and its effect on the surrounding geometries.

So far, we have defined the facade's surface and the function that generates the hexagonal and attracted elements. Therefore, we still need to define the function that places the elements on the facade. For this, we receive a function that distributes the elements in an Alternated-Grid. The function ***alternatedGrid*** is a Higher-Order Function and it receives four arguments:

1. the function ***element***, which generates hexagonal elements with attracted size;
2. the function ***straightGeometry***;
3. the number of elements to produce horizontally (***n***);
4. the number of elements to produce vertically (***m***).

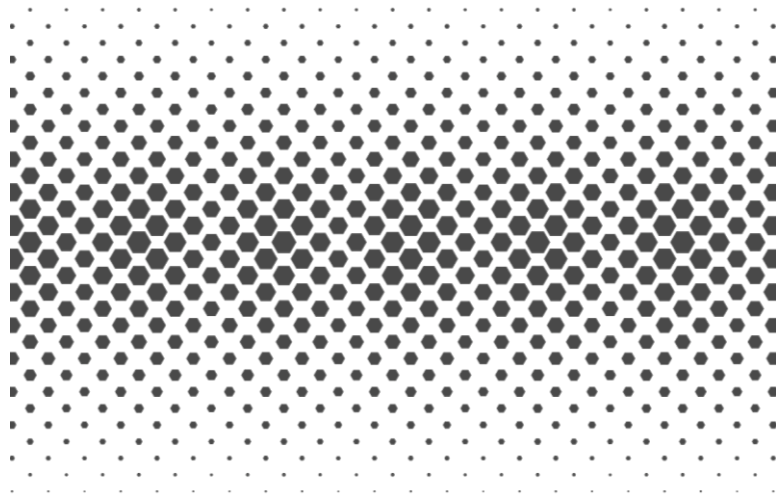

Fig.9.23 – The end result of the function *alternatedGrid*.

This facade is also Perforated, which means we have to subtract the set of elements (already distributed in an alternated-grid) from the straight surface produced by the function *straightGeometry*. As a result, we obtain a model as the one in Fig.9.24.

So far, we have explained the generation process of this facade and, in this section, we explore different possible variations of its design only by changing the values of the parameters.

OFFICE1 – Imagine the attractor-line is moved or changed for another curve, the number of perforations is increased or decreased, or else the geometry of the perforations is changed by a different shape. All these parameters can be varied, thereby producing several different designs as results.

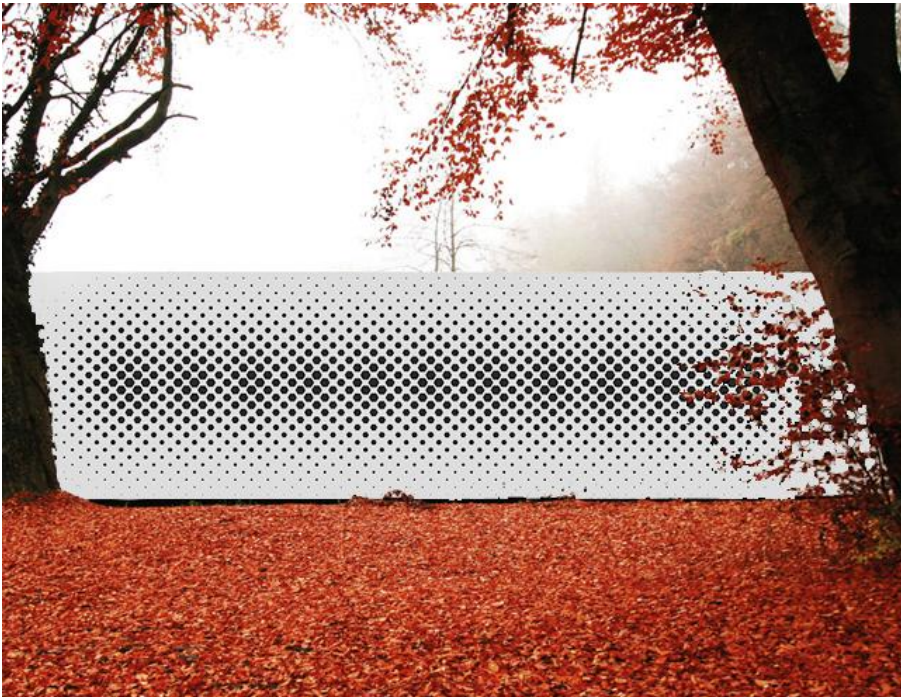

Fig.9.24 - An example of the Campus Netzwerk Office similar to the original facade.

The Image above (Fig.9.24), which resembles the original facade of the Campus Netzwerk Office, was produced using a straight attractor-line placed horizontally at the center of the facade's surface. As a result, this facade design is composed by a grid of hexagonal perforations whose sizes decrease gradually from the facade's center to its ends.

OFFICE2 – Now, imagine we change the location of the attractor-line to the facade's bottom, which corresponds to a line between the points $(2.5 \ 0 \ 0)$ and $(12.5 \ 0 \ 0)$. Consequentially, this change makes the perforations vary their sizes from the facade's bottom to its top. The resulting model corresponds to Fig.9.25.



Fig.9.25 – An example of the Campus Netzwerk facade with the attractor-line at its bottom.

OFFICE3 – As another example, imagine we rotate the attractor-line so as to be along the facade's diagonal: a line between the points $(0\ 0\ 0)$ and $(15\ 0\ 4)$. As a consequence, this change produces again an automatic variation of the perforations' size, which now decrease from the diagonal line to the facade's ends (see Fig.9.26).

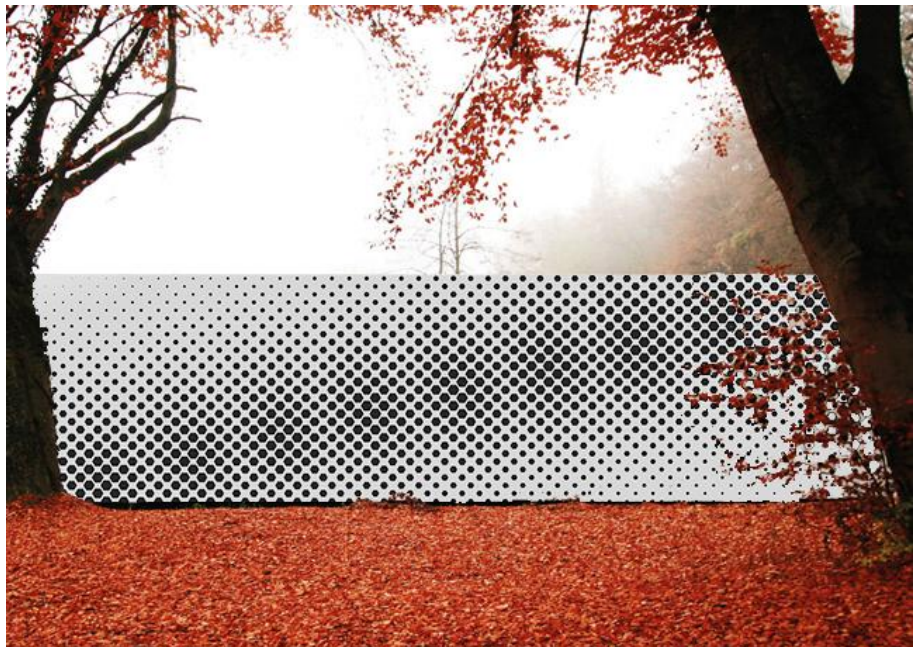

Fig.9.26 – An example of the Campus Netzwerk with the attractor-line placed in the diagonal.

OFFICE4 – Now, let us return to the first example OFFICE1, with the straight attractor-line placed horizontally at the facade’s center. Other possible variation that we can apply to this model is changing the value of the attraction’s magnitude. In this example, we invert the magnitude’s value of the first example OFFICE1, thereby resulting the model in Fig.9.27.



Fig.9.27 – An example of the Campus Netzwerk with the attractor-line in the facade’s center but with the magnitude’s value inverted.

OFFICE5 – The attractor-line can also correspond to non-straight lines and, in this example, we change the straight line by a sinusoidal curve. This variation originates the model in Fig.9.28. On the other hand, the model in Fig.9.29 results from the same attractor-line, but with the magnitude’s value inverted. Note that we can select any type of curve to be the attractor-line.



Fig.9.28 – An example of the Campus Netzwerk Office with a sinusoidal attractor-line.

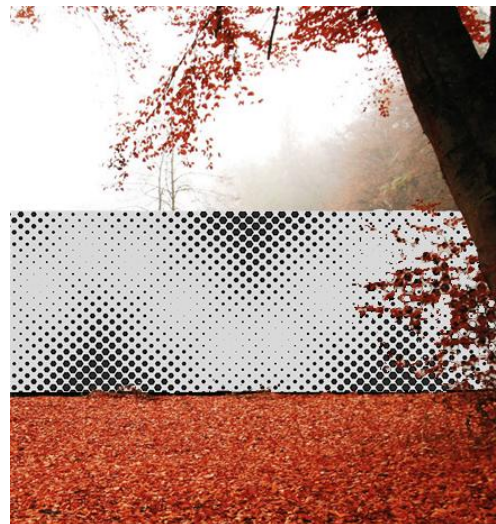

Fig.9.29 – An example of the Campus Netzwerk Office with a sinusoidal attractor-line with inverted magnitude.

OFFICE6 – Finally, in our last two examples we change the number of perforations that composes the facade and also their geometry.

For the first example, we define that the facade's model has half the perforations of the previous example OFFICE1 (Fig.9.24), i.e. the n and m values are divided by two. The resulting model has less but larger perforations and it is represented in Fig.9.30.

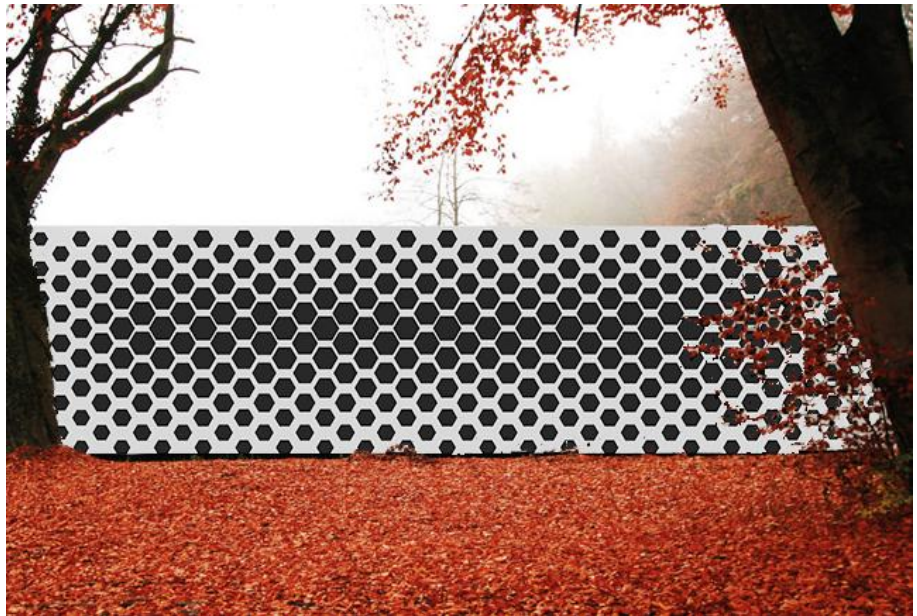

Fig.9.30 – An example of Campus Netzwerk Office with half the perforations.

For the second example, we change the shape of the perforations of the first model (OFFICE1) from Hexagonal geometry to Circular geometry, thereby resulting the model in Fig.9.31. To produce this design variation, we maintain the selected algorithms for the first model (their implementation and structural organization), except the function that shapes the elements, which is now the function *circularGeometry*. As a result, the resulting model is composed by the same Alternated-Grid, but now with circular perforations and it is possible to further change the perforations' geometry for any type of shape, thereby producing several different models as result.



Fig.9.31 – An example of Campus Netzwerk Office with circular perforations.

9.2.3 HOUSE AAG, SPAIN

Located in Albuixech (Spain) this house is a Manuel Cerdá Pérez project and it was built in 2007. This project is a normal house with an unusual facade composed by a set of undulated metal stripes develop along the house's width. The metal stripes are horizontal and placed in parallel. The undulation of the stripes has a constant amplitude and frequency, but its initial phase varies alternately between 0 and π . The design of this facade resembles a wicker basket due to its interlaced metal stripes. The table below summarizes the classifications of this facade:

DIMENSION	FACADE GEOMETRY	ELEMENT GEOMETRY	ELEMENT DEFORM.	ELEMENT SIZE	ELEM. DISTRIBU.	FACADE ARTICULA.	MATERIAL / COLOR
	STRAIGHT	STRIPES	UNDULATED	FIXED	ALTERNATED ROWS	JUXTAPOSED	METAL

One of the functions provided by the classifications above is the function *straightGeometry*, which produces a parametric surface with a straight geometry. We define that the length of this surface has 5,3 meters and the height has 7,5 meters.

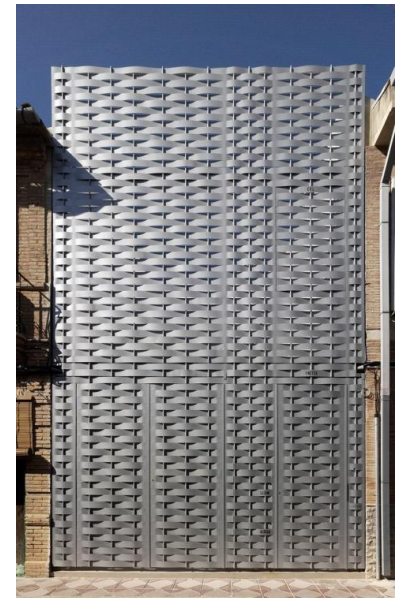

Fig.9.32 - Photography of the House AAG (source: www.archilovers.com/)

The function provided by the Element's Geometry dimension produces stripes as elements, which length and width are defined by us. The next two dimensions (Element's Size and Deformation) inform us that these stripes have equal sizes and are deformed according to the function *undulatedDeformation*. Thus, by combining these functions together (*stripeGeometry*, *fixedSize* and *UndulatedDeformation*) we can implement the function that generates the facade's elements. In addition, we need to define the undulation's properties to distort the elements, such as its amplitude, frequency and phase. We decide that the *amplitude* and *frequency* parameters can be controlled by the user to provide a model with a greater flexibility.

In addition to the horizontal stripes, the facade of the House AAG is also composed by a set of vertical cylinders, which are strategically placed at the points where the horizontal stripes reach their maximum amplitude (Fig.9.33).



Fig.9.33 - The placement of the cylinders: they are placed at the points where the stripes have their maximum amplitude.

So far, we have a function to produce the facade's surface and other to generate the facade elements. However, we still have to place the elements along the facade. For this, we have available the function *alternatedRows*, which distributes the elements in alternated rows of two along the facade's height. This alternation is done between stripes with sinusoids of different phases (0 or π). This function receives as arguments:

1. the function ***element***, which generates the undulated stripes intercalated with the vertical cylinders;
2. the function ***straightGeometry***;
3. the number of elements to produce horizontally (***n***).

The number of cylinders depends on the value of the sinusoid's frequency, since two cylinders are placed in each cycle of the sinusoid.

The Articulation of this facade is made through the juxtaposition of the elements, i.e. the union of the elements compose the facade's surface. This dimension provides functional operators to unify and place the elements together (side by side) into a unique skin (Fig.9.34).

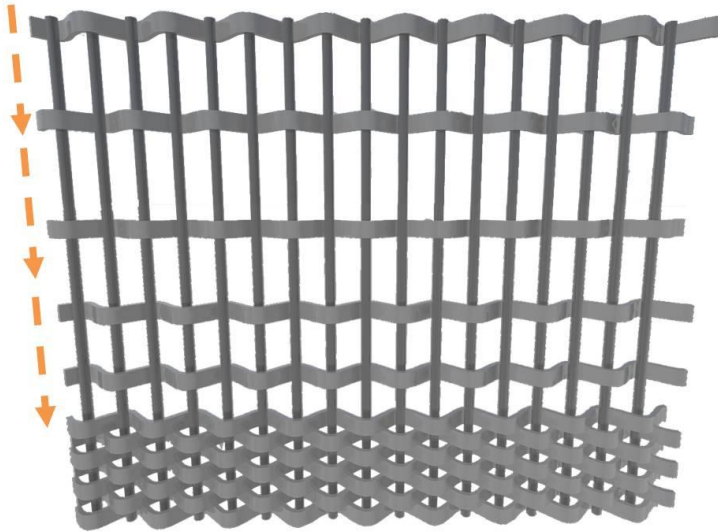

Fig.9.34 - Representation of the facade's articulation: the metal stripes are placed horizontally and side by side and the cylinders are placed vertically.

We have described how this facade design is generated using the algorithms provided by the corresponding classifications. In the following sections, we explore different possible variations of this facade design, simply by varying some of its parameters.

In practical terms, we can change this facade's model length and height sizes (l and h), the number of stripes (n), the thickness of the stripes (e) and the value of the amplitude and frequency of the stripes' undulation (a and f). The variation of these parameters produces several different models as result.

AAG1 – Our first example tries to produce a model similar to the existing facade, thereby the values chosen for its parameters resulted from an analysis of the House AAG facade's design. We conclude that the original facade is composed of approximately 50 metal stripes ($n=50$), each one with an undulation frequency of 8 ($f=8$) and an amplitude of 0.06 meters ($a=0.06$). The table blow summarizes the values of this facade's design, while the Fig.9.35 shows the resulting model:

AMPLITUDE	FREQUENCY	THICKNESS (E)	NUMBER	HEIGHT	LENGTH
0.06M	8	0.03M	80	7.5M	5.3M

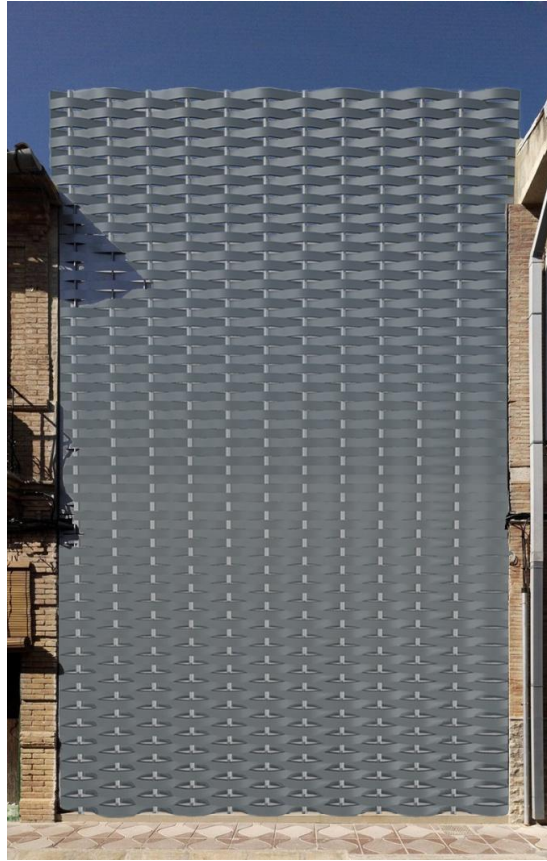

Fig.9.35 - The model of the House AAG with a size of 7.5X5.3 m, with 80 horizontal stripes of frequency = 8 and amplitude=0.06m.

AAG2 – In our second example, we change the parameter *number of stripes* of the previous model: we increase its number from $n=80$ to $n=130$ stripes. We maintain all the other parameters as in the previous model. Consequentially, as the facade keeps its height dimension ($h=7,5m$) and the number of stripes increases to 130 stripes, the width of the stripes decreases automatically so that all the stripes can fit the facade’s surface (see Fig.9.37).

In practical terms, this example has more stripes with smaller widths and, if we further increase the number of stripes, the strips’ widths will decrease proportionally. On the other hand, if we decrease the number of stripes, their widths increase proportionately.

As a practical example, imagine we decrease the number of stripes from $n=80$ to $n=30$ stripes, the resulting facade is in Fig.9.36 and it is composed by less stripes, but with larger widths.

AMPLITUDE 0.06M	FREQUENCY 8	THICKNESS(E) 0.03M	NUMBER₃₆ 30	HEIGHT 7.5M	LENGTH 5.3M
AMPLITUDE 0.06M	FREQUENCY 8	THICKNESS(E) 0.03M	NUMBER₃₇ 130	HEIGHT 7.5M	LENGTH 5.3M

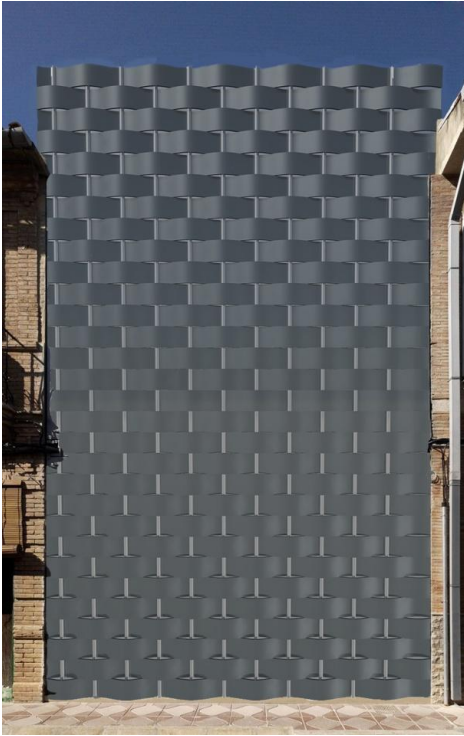

Fig.9.36 - The model of House AAG with 30 metal stripes.

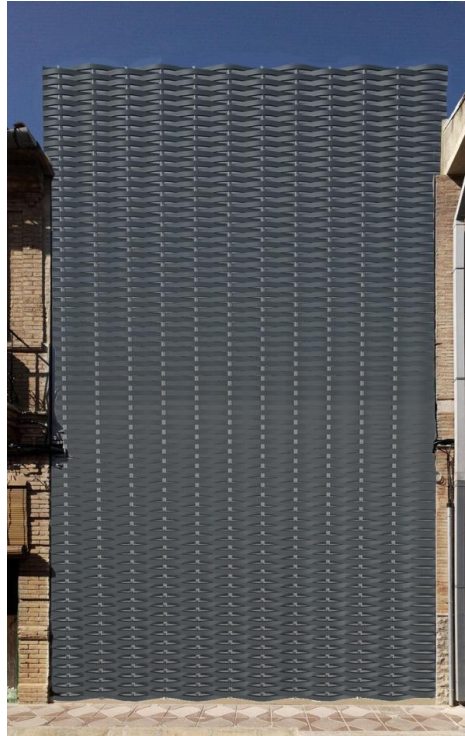

Fig.9.37 - The model of House AGG with 130 stripes.

AGG3 – In the next example, we change the value of the sinusoid's amplitude and we maintain all the other parameters equal to the first example (with the number of stripes $n=80$). The parameter *amplitude* controls the side extension of the sinusoid curve and, when it has a small value, the curve is less pronounced, otherwise, the curve is more pronounced.

To generate the model in Fig.9.38, we increase the value of the amplitude from $a=0.06\text{m}$ to $a=0.14\text{m}$, while in the second model (see Fig.9.39) we decrease the amplitude's value from $a=0.06\text{m}$ to $a=0.02\text{m}$. When comparing both models, we can visualize the differences between them and the original example **AGG1**: the accentuation of the strips deformation increases with the amplitude.

AMPLITUDE₃₈ 0.14M	FREQUENCY 8	THICKNESS(E) 0.03M	NUMBER 80	HEIGHT 7.5M	LENGTH 5.3M
AMPLITUDE₃₉ 0.02M	FREQUENCY 8	THICKNESS(E) 0.03M	NUMBER 80	HEIGHT 7.5M	LENGTH 5.3M

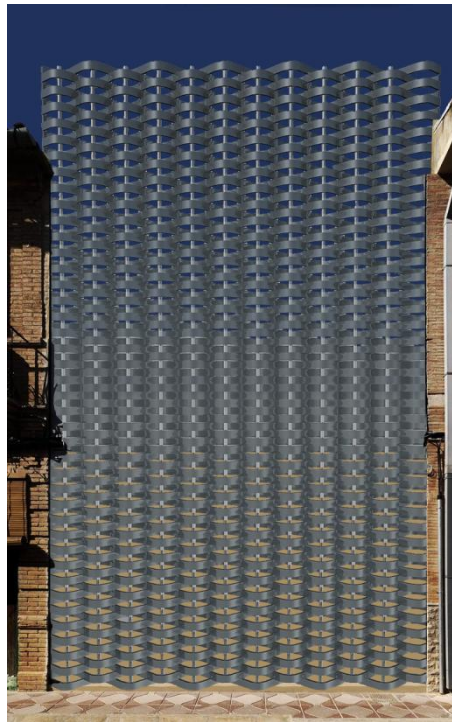

Fig.9.38 - The model of the House AAG with an amplitude of 0.14.

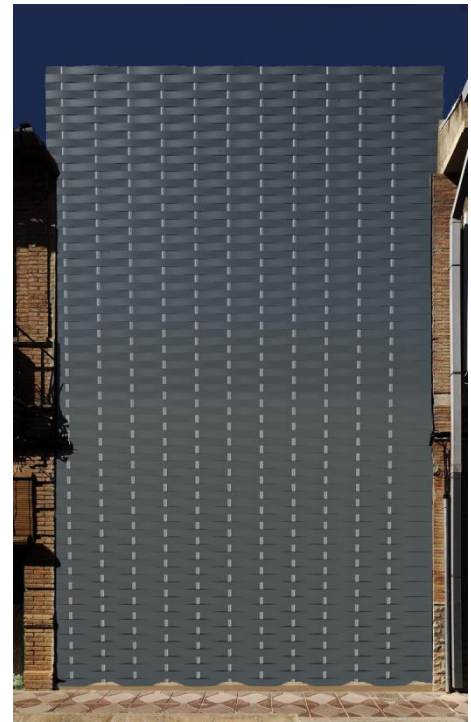

Fig.9.39 - The model of the House AAG with an amplitude of 0.02

AAG4 - Finally, we change the model's frequency values, which control the number of cycles per time unit of a sinusoid curve. When the frequency has a high value, the sinusoid curve has a larger number of cycles, i.e. more waves. Otherwise, if the frequency is low, the sinusoid curve has less cycles.

To generate the model in Fig.9.40, we decrease the parameter of the frequency from $f=8$ to $f=5$. To generate the second example (Fig.9.41), we increase the sinusoid frequency from $f=8$ to $f=11$. When comparing both models with the first example (Fig.9.35), we conclude that the main difference between them is the degree of the stripes undulation, i.e. the number of waves of each strip increases or decreases depending on its frequency value.

AMPLITUDE 0.06	FREQUENCY ₄₀ 5	THICKNESS(E) 0.03M	NUMBER 80	HEIGHT 7.5M	LENGTH 5.3M
AMPLITUDE 0.06	FREQUENCY ₄₁ 11	THICKNESS(E) 0.03M	NUMBER 80	HEIGHT 7.5M	LENGTH 5.3M

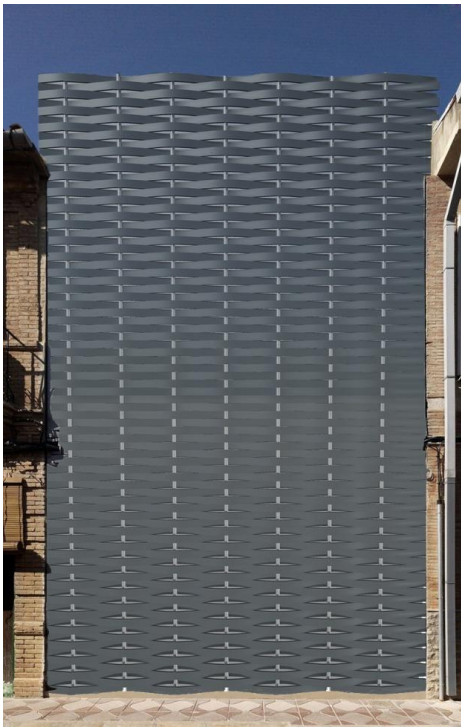

Fig.9.40 - The model of the House AAG with a frequency of 5.

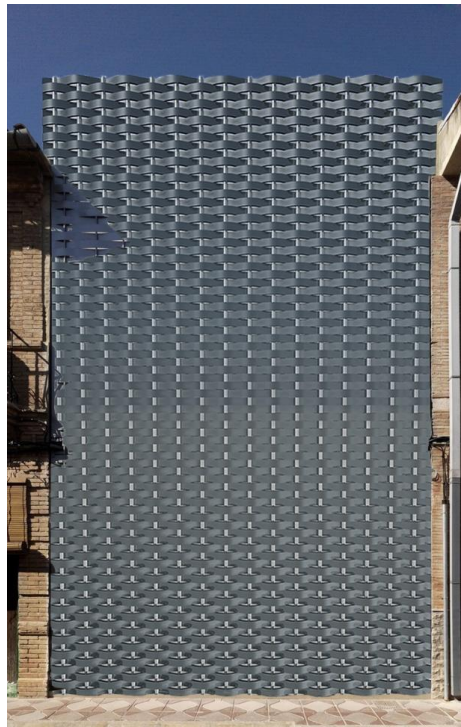



Fig.9.41 - The model of the House AAG with a frequency of 11.

9.2.4 GANTENBEIN VINEYARD, SWITZERLAND

This project is an extension of a vineyard in Switzerland and its facade was design by the architects Gramazio & Kholer. The initial design was a common concrete structure filled with bricks, but through a robotic production method it was possible to place the bricks precisely according to a desired angle in the right place. Depending on the angle in which the bricks are placed, each one reflects light differently, staying with different degrees of light. Comparatively to a computer screen, this different degrees of lightness do the same effect as pixels in images. In this case, the rotated bricks produce an image similar to giant grapes.

This project was already classified in Charter 7 and, In this section, we apply the algorithms provided by its classifications to generate the corresponding model. The table below summarizes the classifications of this facade design:

DIMENSION	FACADE GEOMETRY	ELEMENT GEOMETRY	ELEMENT SIZE	ELEM. DISTRIBU.	ELEMENT ROTATI.	FACADE ARTICULA.	MATERIAL / COLOR
	STRAIGHT	RECTANGULAR	FIXED	ALTERNATED GRID	PICTORIAL	STACKED	MASONRY

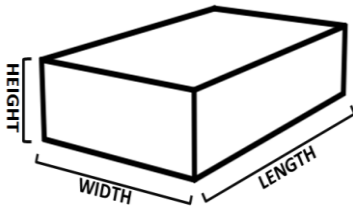

Fig.9.42 - The parameters of the brick: Height, Width and Length.

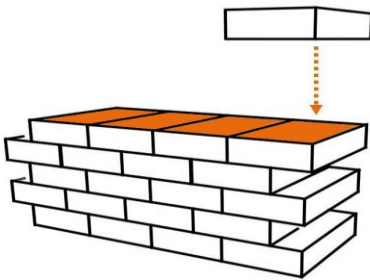

Fig.9.43 - The stacking of the bricks in an alternated-grid.



Fig.9.44 - Photography of purple balls (source: <http://www.candymachines.com/>)

The Vineyard's facade has straight geometry and for its dimensions we chose a length of 19 meters and a height of 5 meters. In addition, we know that this facade is composed by stacked elements, corresponding to the bricks. Their shape is parallelepiped and to generate this shape we receive the function *rectangularGeometry* from the Element's Geometry dimension, which produces either rectangular surfaces or parallelepiped boxes. As the bricks do not suffer any deformation nor size variation, we can already define the function that generates the elements – the function *element*. This function receives as argument the function that generates a parallelepiped shape, which dimensions (length, width and height) are defined by us (Fig.9.42).

The next step is placing the elements (the bricks) so as to be stacked on each other (Fig.9.43). For this, we receive a function from the Element's Distribution dimension, the function *alternatedGrid*, which makes a distribution of the elements similar to the existing facade. This function is a Higher-Order function that receives as arguments:

1. the function ***straightGeometry***: because it requires the surface points to place the elements;
2. the function ***rectangularGeometry***: which generates boxes as elements;
3. the number of elements to produce horizontally (**n**);
4. the number of elements to produce vertically (**m**);
5. the function ***pictorialRotation***: which rotates the elements according to an image.

The function *pictorialRotation* was provided by the Element's Rotation dimension, which means that the facade's elements are rotated in order to produce an image. To implement this function we need to select the image that we want to produce, which in this case is an image similar to giant grapes.

After selecting the image with a design similar to the existing facade (Fig.9.44), we are able to combine all the functions together in order to generate the model of the Gantenbein Vineyard facade.

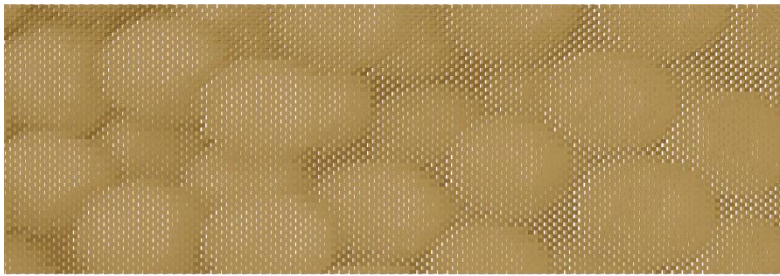

Fig.9.45 – The pattern created by the rotated bricks (above) and the picture selected for the function *pictorialRotation* (bellow).

VINEYARD1- The first model tries to approach the original facade of the Gantenbein Vineyard, which is visible in Fig.9.46. As we can see, the bricks' rotation produce different light reflections, which correspond to the image's pixels. The different degrees of light produce together the selected image.

FACADE GEOMETRY	ELEMENT'S GEOMETRY	ELEMENT'S SIZE	ELEMENT'S DISTRIBUTION	ELEMENT'S ROTATION	FACADE ARTICUATION
STRAIGHT	RECTANGULAR	FIXED	ALTERNATED-GRID		STACKED



Fig.9.46 - The model of the Gantenbein Vineyard with 19m of length and 5m of height.

VINEYARD2 - There are several ways to produce images on a facade and, in the next examples, we explore other possibilities for the generation of this same image. In this section, we produce the selected pattern using different strategies:

1. by using perforations with different sizes;
2. by using appliqués with different sizes;
3. by using a grid that narrows or expands according to the color intensity of the corresponding pixel;
4. by placing the bricks more forward or backward.

In the first example, we produce the pattern through the movement of the bricks forward or backward, according to the color of the corresponding pixels. This produces a pictorial effect similar to the one produced by the rotated bricks (visible in the Fig.9.47).



Fig.9.47 - The model of the Gantenbein Vineyard with bricks placed backward and forward.

VINEYARD3 - In the following example, we produce the pattern of the “giant grapes” using squared perforations with different sizes, according to the color of the corresponding pixel. In this example, the elements have a size variation controlled by a function provided by the Element’s Size dimension, the function *pictorialSize*. Then, these elements are subtracted from the facade’s surface, instead of being stacked. In this example, the facade’s type of articulation is changed from Stacked to Perforated, while the

elements' geometry is changed from Fixed to Pictorial. The resulting model is represented in Fig.9.48.

FACADE GEOMETRY	ELEMENT'S GEOMETRY	ELEMENT'S SIZE	ELEMENT'S DISTRIBUTION	ELEMENT'S ROTATION	FACADE ARTICULATION
STRAIGHT	SQUARED		REGULAR-GRID	—	PERFORATED



Fig.9.48 - The model of the Gantenbein Vineyard with squared perforations.

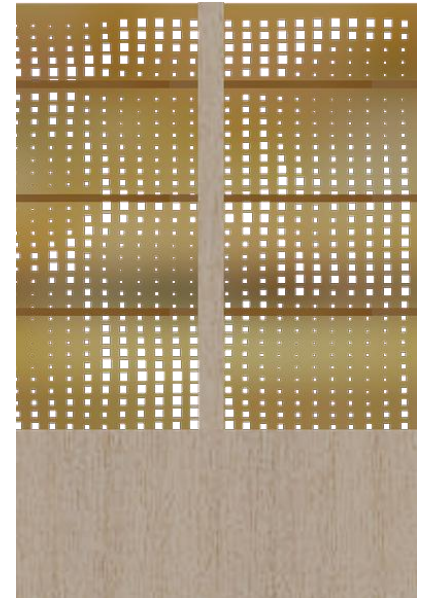

In addition, we can produce this same pattern by using circular perforations instead of squared perforations (see Fig.9.49). For this, we change the Element's Geometry from Squared to Circular and we maintain all the other parameters.



Fig.9.49 - The model of the Gantenbein Vineyard with circular perforations.

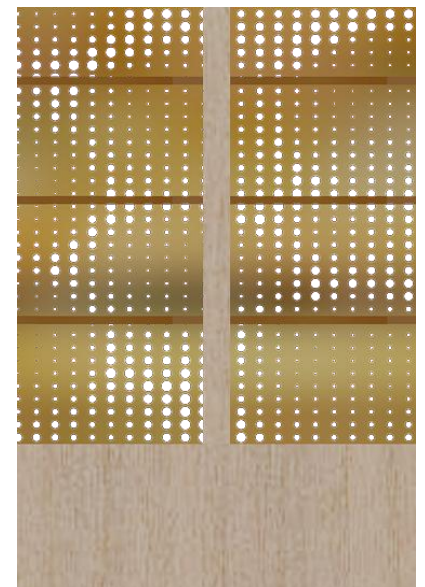

VINEYARD4 – In the following example we join the elements with the facade’s surface, instead of subtracting them, and we obtain a similar result. This example has now an articulation of Applied elements with Squared geometry (see Fig.9.50).

FACADE GEOMETRY	ELEMENT'S GEOMETRY	ELEMENT'S SIZE	ELEMENT'S DISTRIBUTION	ELEMENT'S ROTATION	FACADE ARTICULATION
STRAIGHT	SQUARED		REGULAR-GRID	—	APPLIED

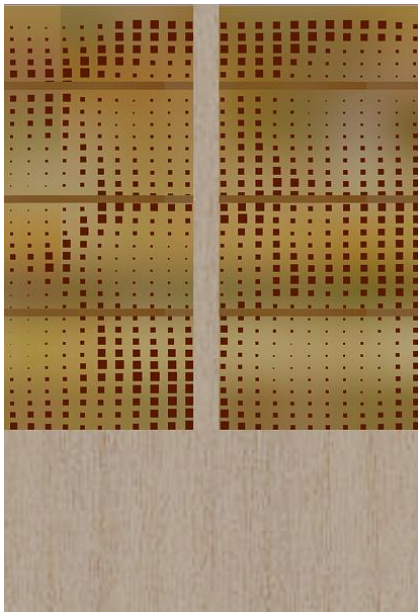

Fig.9.50- The model of the Gantenbein Vineyard with squared Appliques.

As in the previous example, we can also change the shape of the appliques from Squared geometry to Circular. The resulting model is similar to the previous one, as it is visible in Fig.9.51.

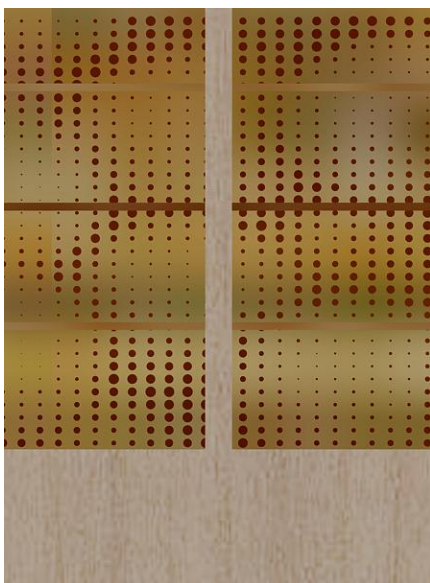

Fig.9.51- The model of the Gantenbein Vineyard with circular appliques.

VINEYARDS5 – Finally, in our last example, we generate this pattern using a grid that narrows and expands according to the color of the corresponding pixel. We produce this grid with two crossed cylinders placed between the grid's four points (Fig.9.52). The narrow and expansion of this grid results from the increase and decrease of its radius size, which is controlled by the corresponding pixel. The resulting skin is a grid that reproduces the selected image through the variation of its openings' size (Fig.9.53).

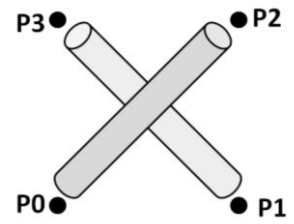
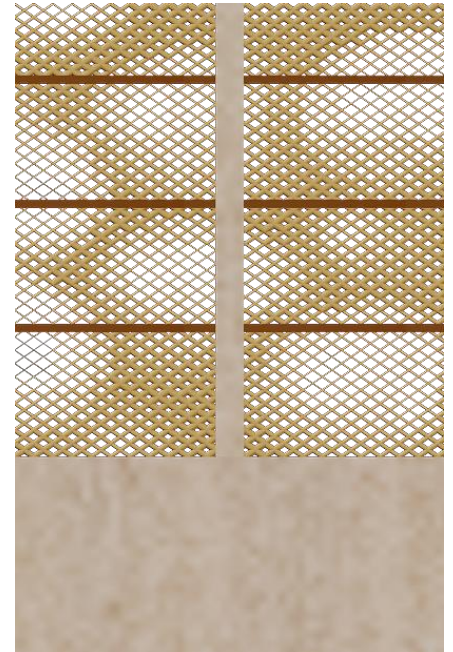

Fig.9.52 - The positioning of the cylinders in order to create the grid.



Fig.9.53 - The model of the Gantenbein Vineyard with a grid producing the facade pattern of the grapes.



9.2.5 FACIM WATERFRONT IN MAPUTO, MOZAMBIQUE



Fig.9.54 - A Rendering of the FACIM WaterFront Project by Bak Gordon (source: http://www.bakgordon.com/200_projects/)

Our last example is a project of Bak Gordon's Studio together with FVA and PROAP for the city of Maputo (Fig.9.54), which has not yet been built. As we explained in this thesis introduction, this project was the starting point of our work, thereby inspiring us to create this framework. The project consists of a big quarter, whose functional program includes areas of business, commerce, housing and hotels. This wide functional program led to an urban planning solution in which the vertical buildings stand out as the fundamental project image.



Fig.9.55 - The African Motif that inspired the pattern (source: Bak Gordon Studio).

The towers' skin is characterized by a pattern inspired in African motifs (Fig.9.55), which is produced using metallic profiles. This pattern suffers a scale variation from one side of the facade to the other, which is produced by a sequence of several modules with patterns with a gradually smaller scale (see Fig.9.56). Although this sequence of patterns creates an interesting effect, if its size variation was produced using an algorithmic approach, the resulting skin would be more continuous and controllable. In addition, it would also facilitate the testing of other possible variations of this pattern, with almost no effort and time spent.

In this section, we explore and generate the skin pattern of the FACIM WaterFront project using an algorithmic approach. For this, we apply some of the functions available in our framework and, when necessary, we develop some additional algorithms.

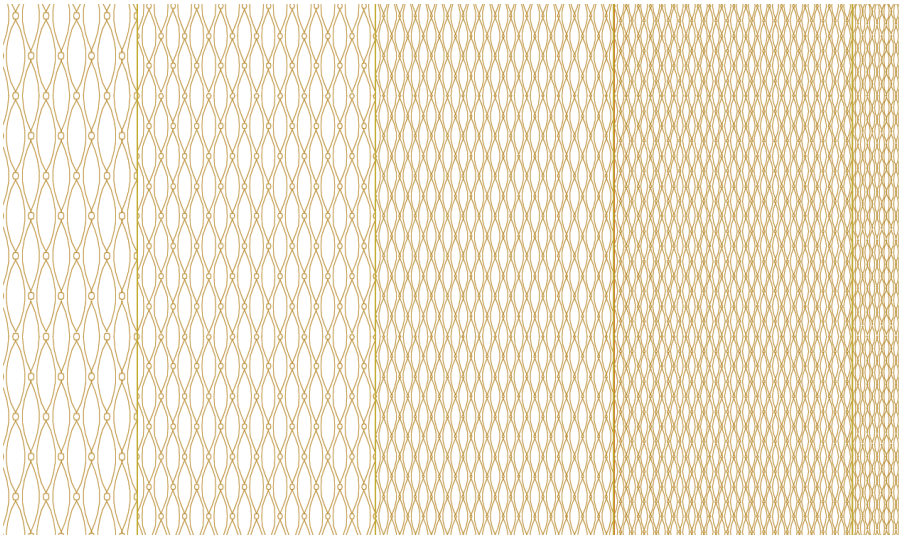

Fig.9.56 - The gradation of the skin's pattern: each module corresponds to a different scale and the modules are organized in descending order of scales (source: Bak Gordon Studio).

In a first stage, we analyzed the skin's pattern and we concluded that it is composed by elements with a Pictorial geometry. This means that to create the function *element*, we had to implement the geometry ourselves.

We started by defining the element that constituted the pattern. For this, we divided the pattern into a grid (like the process explained in Charter 8 with the Library of Birmingham) and we considered the element to be the design that was within the grid squares (Fig.9.57 and Fig.9.58)

Then, we defined the type of elements distribution along the surface. We classified it as Alternated-grid (Fig.9.59) and, to distribute the elements on the skin we used the function provided ***alternatedGrid***. This function receives four arguments:

1. the function ***straightGeometry*** from the Facade's Geometry dimension;
2. the function ***element***, which produces an element like the one in Fig.9.58;
3. the number of elements to produce horizontally and vertically (***n*** and ***m***).

In addition, we want the elements to vary their sizes along the facade length. For this, we have to implement inside the function *element* a function that produces an increasing size variation. Our framework has available a function capable of producing this type of size variation, the *increasingSize* function.

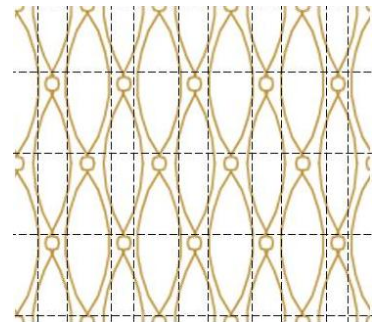

Fig.9.57 - The pattern fragmentation into parts to find the element base.



Fig.9.58 - The pattern element.

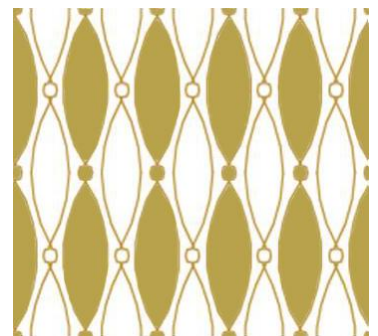

Fig.9.59 - The overlapping of two grids of elements: elements distribution in Alternated-Grid.

After implementing these functions together, we can produce a facade similar to the original project, which is visible in the image below:

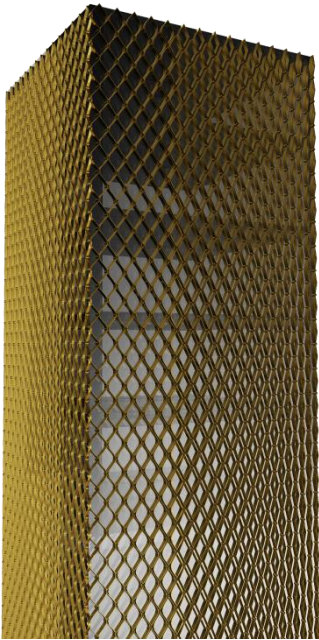



Fig.9.60 – The tower with the increasing size variation along its length.

FACADE GEOMETRY	ELEMENT'S GEOMETRY	ELEMENT'S SIZE	ELEMENT'S DISTRIBUTION	ELEMENT'S ROTATION	FACADE ARTICUATION
STRAIGHT		INCREASING	ALTERNATED-GRID	—	WEB

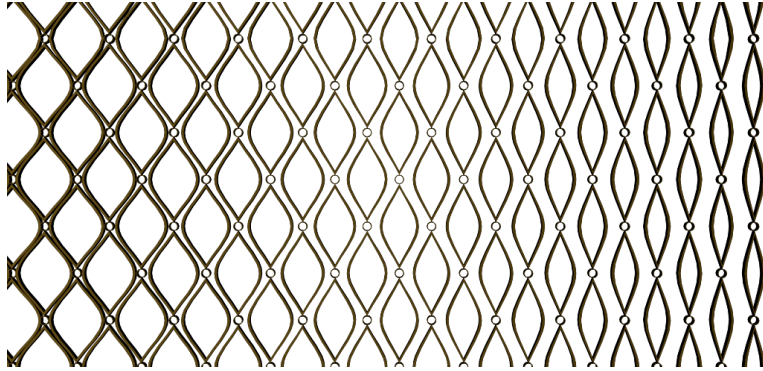

Fig.9.61 – The pattern with a horizontal increasing size variation.

As another example, we produce this same pattern but with an increasing size variation along the facade's height (Fig.9.62). In addition, we can also produce this pattern with a decreasing size along the facade's height (Fig.9.63).



Fig.9.62 – An example of a tower's skin with an increasing size variation along its height.



Fig.9.63 - An example of a tower's skin with a decreasing size variation along its height.

FACIM1 – Imagine we want to produce another example of this tower’s skin, but with an attracted size variation. For this, we create an attractor-point in the center of the building’s facade (Fig.9.64).

Changing the type of size variation using our framework is much easier than using the traditional approach, thereby solving the initial problem of this project. Thus, our framework allows the rapid exploration and visualization of several design solutions for the tower’s skin in a short period of time and with almost no effort.

As another example, we produce another variation of the tower’s skin with the attractor-point placed on its left side (Fig.9.65).

FACADE GEOMETRY	ELEMENT’S GEOMETRY	ELEMENT’S SIZE	ELEMENT’S DISTRIBUTION	ELEMENT’S ROTATION	FACADE ARTICUATION
STRAIGHT		ATTRACTED	ALTERNATED-GRID	—	WEB



Fig.9.64 - An example of a tower’s skin with an attracted size variation: the attractor-point is placed approximately in the facade’s center.



Fig.9.65 - An example of a tower’s skin with an attracted size variation: the attractor-point is placed on the facade’s left side.

FACIM2 – As another example, we can use a vertical sinusoidal curve as an attractor-line. As a result, this attractor curve produces a pattern with an undulating size variation (Fig.9.66).



Fig.9.66 – An example of a tower's skin with a sinusoidal attractor-line.

FACIM3 – Finally, imagine we want to produce a skin with a different geometry. For this, we simply change the type of geometry in the Facade's Geometry dimension. As a first example, we change the skin's geometry from Straight geometry to Cylindrical geometry and, then, the pattern is automatically applied to the selected surface.



FACADE GEOMETRY	ELEMENT'S GEOMETRY	ELEMENT'S SIZE	ELEMENT'S DISTRIBUTION	ELEMENT'S ROTATION	FACADE ARTICUATION
CYLINDRICAL		ATTRACTED	ALTERNATED-GRID	—	WEB



Fig.9.67 – An example of the tower's skin with a Cylindrical geometry.

In addition, we can further change this tower's geometry for more complex shapes and, as our last three examples, we change it from Cylindrical geometry to Sinusoidal and Co-sinusoidal geometries (see Fig.9.68).

FACADE GEOMETRY	ELEMENT'S GEOMETRY	ELEMENT'S SIZE	ELEMENT'S DISTRIBUTION	ELEMENT'S ROTATION	FACADE ARTICULATION
SINUSOIDAL & CO-SINUSOIDAL		ATTRACTED	ALTERNATED-GRID	—	WEB

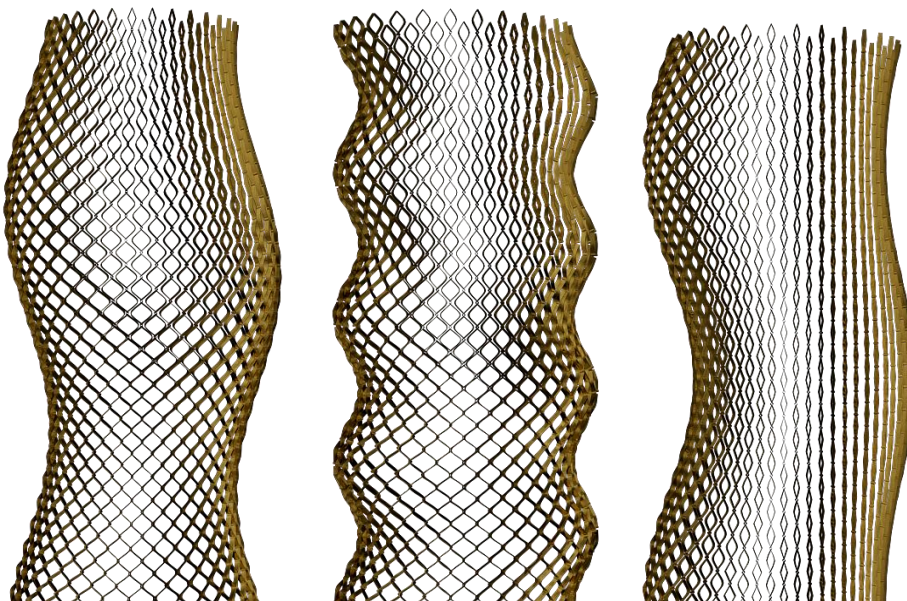

Fig.9.68 – Three examples of the tower's skin with Sinusoidal and Co-sinusoidal geometries.

To sum up, in this section we explored a set of different variations for each of the selected projects. Still, the design changes that we explored here are only a small part of all possible variations, since our framework is based on an algorithmic approach, which gives us the maximum flexibility for the design exploration and where the changes are automatically updated to the models. We can produce these variations simply by changing the values of the parameters, thereby not being necessary to erase and redraw the designs as in the traditional approach.

In the previous chapters, we started by describing our framework and its classification and, then, we made some practical applications using the classification and the algorithms available in it. In this section we summarize other possible applications for this framework, besides the generation of facades.

We started this thesis referring the need for a design approach that controls change and enables the experimentation of several instances of a design in the generation of building skins. For this, we have created this framework based on an algorithmic approach to design. Nevertheless, our framework can have other potential applications, mostly in interior design.

Contemporary architecture is enriched with stunning skins and patterns, but this complex reality is not limited to the buildings' skin. Interior design has also been expressing its tendency to explore patterns and skins, which then are applied on several items such as walls, tables, carpets, curtains, stair rails, etc. This tendency is visible in the work of several international and national studios and here we summarize some of them.

Linear elements such as wallpapers, divider walls and false ceilings have been extensively explored in the practice of interior design. False ceilings have been gaining a lot of attention in interior design and, nowadays we are assisting to a growing use of these ceilings with complex geometries and elaborate patterns in houses, offices, restaurants, etc (see Fig.10.1). Usually, false ceilings are surfaces with a linear or complex geometry, on which it is applied several patterns or textures (Fig.10.5). We believe that it is possible to use our framework to generate this type of interior design elements, as it also produces surfaces on which applies several designs and patterns. The image in Fig.10.3 shows an example of a false ceiling with a more exotic geometry, which almost seems to be a ceiling sculpture. Its skin is composed



Fig.10.1 – False Ceiling: Bar Bô Zen in Braga by Central Arquitetos (source: <http://centralarquitectos.com/>)

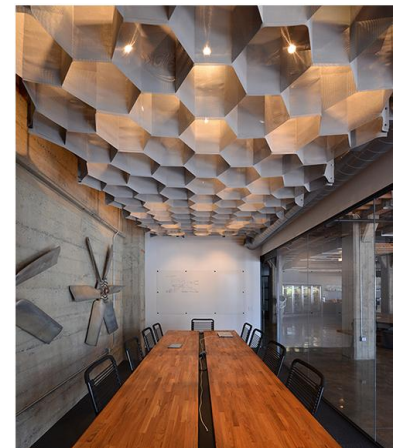

Fig.10.2 – False Ceiling: Hexcell Fabric Ceiling, Heavybit Industries, Lisa Iwamoto & Craig Scoot

by a pattern similar to one already exemplified in this thesis, more precisely in Chapter 9, in one of the framework's application examples. This example proves that our framework can also be used in the practice of interior design.



Fig.10.3 – False Ceiling: Common Weathers NYSCI, SOFTLab (source: <http://softlabnyc.com/>)

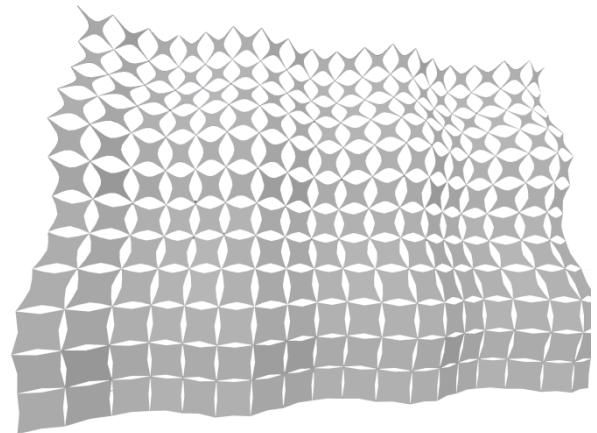

Fig.10.4 – The pattern generated by using our framework.

The same happens with wallpapers and wall decorations. Generative design has been also present in the generation of this type of interior elements, by showing its potential in the decoration of home interiors, cafés, exhibitions, etc. In addition, the application of high reliefs in interior walls is a field that has been re-explored in current architecture and it uses shapes and patterns based on a parametric approach (see Fig.10.7). In some cases, the textures applied on the walls are continued to other elements, such as ceilings, floors and counters, using the same design discourse (pattern) and, sometimes, using a unique skin that comprises all the elements in an unique surface (Fig.10.8).

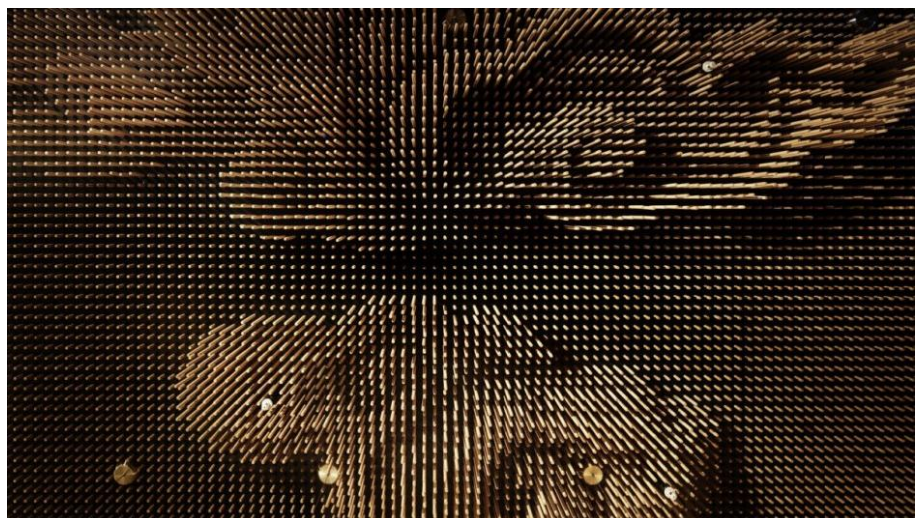

Fig.10.5 – Tsujita LA Ceiling by Takeshi Sano: An image of clouds produced by wooden sticks with different lengths (source: www.contemporist.com)

The use of screen walls (or partition walls) in interior design has also been increasing. Most of these surfaces are perforated with many different and complex patterns (see Fig.10.10). In addition, this tendency to apply parametric patterns or reliefs is also found in kitchen or restaurant/bar counters (see Fig.10.9).

This reality is possible due to the use of a generative approach, which opens the possibility to generate and manufacture complex patterns, some of which we had already in mind but not others. In this section we show some examples of the application of this approach in the design of interior walls, screen walls and counters.



Fig.10.6 - Jeff Dah-Yue SHI design: An interior with the same pattern on all the surfaces (source:www.plataformaarquitectura.cl)



Fig.10.7 – Interior Walls: Roka Akor SF Bar Wall, Matsys Design (source: <http://matsysdesign.com/>)



Fig.10.8 – Interior walls and ceiling: M.A.C YQ Store, Lisa Iwamoto & Craig Scott (source: www.iwamotoscott.com/)

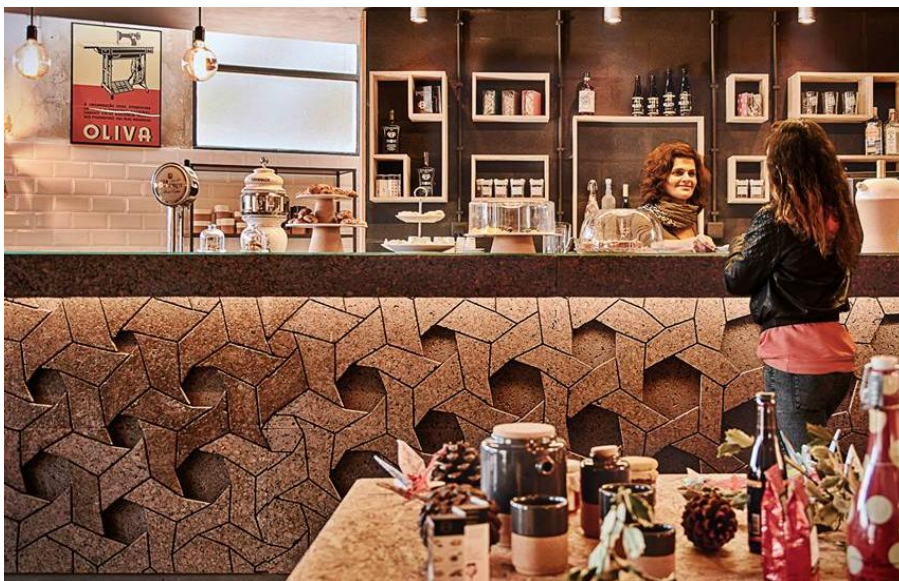

Fig.10.9 – Parametric pattern on a restaurant’s counter: Oliva Palito Coffe Shop by DigitaLAB (source: www.facebook.com/digitalab.pt)



Fig.10.10 – Screen wall pattern: Uniopt Pachleitner Group Headquarters by GS Architects (source: www.archdaily.com)

In practical terms, the application of our framework is similar in both exterior facades and interior design. Moreover, in interior design practice, we can use our framework to explore further designs, such as organic patterns, exotic and intricate geometries, stair rails (Fig.10.11 and Fig.10.12) and several types of furniture (see Fig.10.14).



Fig.10.11 – Parametric Stair Rail + Corian screen by MARCC FORNES/THEVERYMANY (source: <http://theverymany.com/>)



Fig.10.12 – Stair Rails (www.architonic.com)

To sum up, we believe there is a wide range of objects and elements in interior design that we can generate using our framework and, in this section, we have exemplified different types of possible applications.

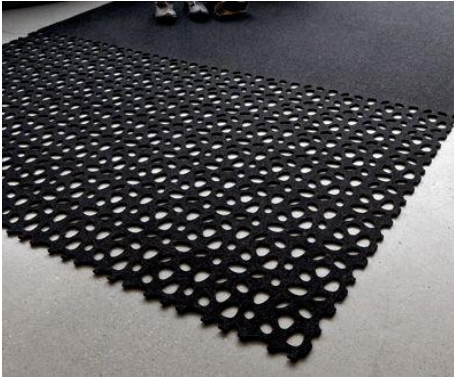

Fig.10.13 – Carpets: River Rock Carpet by Bev Hisey ([www. http://mocoloco.com/](http://mocoloco.com/))



Fig.10.14 – Furniture: Voronoi Chair by Torabi Architect ([source: www.torabiarchitect.com](http://www.torabiarchitect.com))



Fig.10.15 – A site specific installation for the San Gennaro North Gate in New York, designed and produced by SOFTlab ([source: http://softlabnyc.com/](http://softlabnyc.com/))



Fig.10.16 – Vousoir Shell project by Lisa Iwamoto & Craig Scott to the Artists Space Gallery (New York 2008) ([source www.iwamotoscott.com/](http://www.iwamotoscott.com/))



Fig.10.17 – Louis Vuitton Pop-up Store in Selfridges, London, by Marc Fornes/THEVERYMANY, 2012 ([source: http://theverymany.com/](http://theverymany.com/))

11 EVALUATION

In this section we make a brief evaluation of the work developed in this thesis. In a first stage, we developed a methodology to simplify the generation of building skins. Thus, we felt the need to define a classification of facades and we agreed to divide it according to the design stages that we found when using an algorithmic approach. The goal of this classification was to help the designers in the selection of the algorithms that better suit their design intent. In a second phase, we applied the algorithms available in our framework to generate several models as examples, including abstract and existing facades. In addition, we showed the advantages of using, our framework, whether in the creation of new skins or in the exploration of already generated models.







In this chapter we evaluate if our framework is complete and sound. For the first one, we analyze the framework's flexibility i.e. the range of design possibilities and its capacity to generate real facades. We also evaluate the efficiency of our framework's practical application, i.e. the time required for the generation of a facade model.

To evaluate if our work is sound, we compare the time spent in both traditional and algorithmic approaches: we compare the time required to generate a model using our framework with the time required when using a traditional approach. For this, we select two designs of facades, which we produce using both approaches.

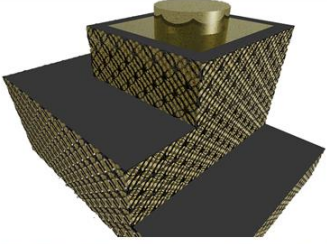
Finally, we evaluate the portability of our framework, i.e. its capacity to generate the same model in several CAD environments, such as AutoCAD, Rhino and REVIT. For this, we select another model as an example, which we then generate by using all supported CAD environments.

11.1 EVALUATING THE FRAMEWORK'S FLEXIBILITY

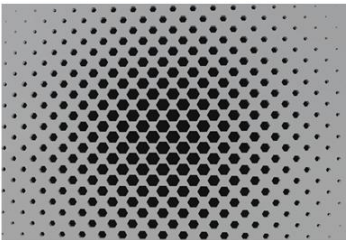
In order to evaluate if our framework is able to produce real facades, we used it to reproduce a set of facades that already exist, like the examples in Chapters 8 and 9. In this section, we summarize some of the real facades that we have re-produced by using the operators provided by our framework. The image below (Fig.11.1) organizes the projects in rows with the photography of real facade on the left side, the model generated by us on the right side and, in the middle, its corresponding classification.

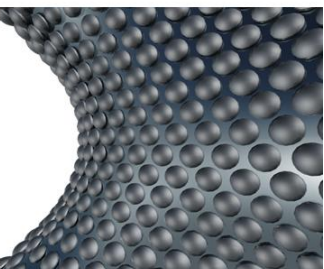
PROJECT	CLASSIFICATION	MODEL
	STRAIGHT FACADE PICTORIALELEMENTS FIXED SIZE REGULAR-GRID LAYERED ARTICULATION	
	STRAIGHT FACADE CYLINDRICAL ELEMENTS FIXED SIZE REGULAR-GRID JUXTAPOSED ARTICULATION	
	STRAIGHT FACADE HEXAGONAL ELEMENTS ATTRACTED SIZE ALTERNATED-GRID PERFORATED ARTICULATION	
	FREE-FORM FACADE SPHERICAL ELEMENTS FIXED SIZE ALTERNATED-GRID APPLIED ARTICULATION	

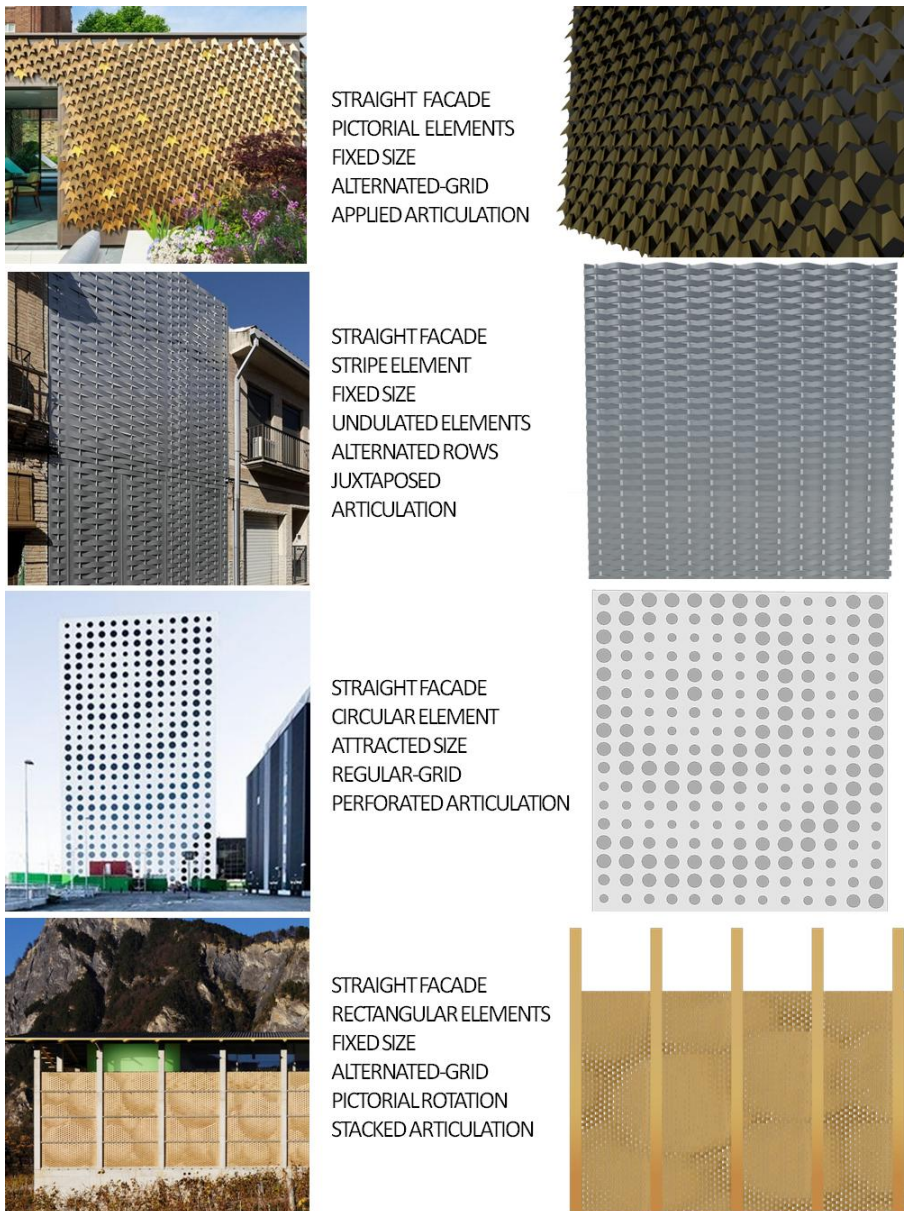

Fig.11.1 - Synthesis of the models produced based on real facades, with their corresponding classification and real project.

We may conclude from the comparison between the real projects and the corresponding models (generated using our framework) that we can achieve a high degree of fidelity.

To evaluate the flexibility of our framework, we have produced several variations on the designs, i.e. the application of changes to the models for analyzing different possible results. In addition, these variations demonstrated the ease and speed with which it is possible to implement changes in the models. Since the variations produced correspond to different values given to the design's parameters, we only have to vary those input values to test different possible results. This is a great advantage of our framework and its design approach: we invest some time implementing the

design's skeleton, which is then rewarded in the phase of experimentation and correction of the model.

In addition, to measure the vastness of our framework, we have produced another set of facade's designs, which was idealized by us. We tried to produce very different design solutions to show how wide is our framework. The image bellow (Fig.11.2) shows a set of possible designs for facades, which were produced using our framework. After analyzing these examples, we can conclude that (1) the range of design possibilities is vast and that, (2) with simple elements and geometries, we can produce highly complex patterns.

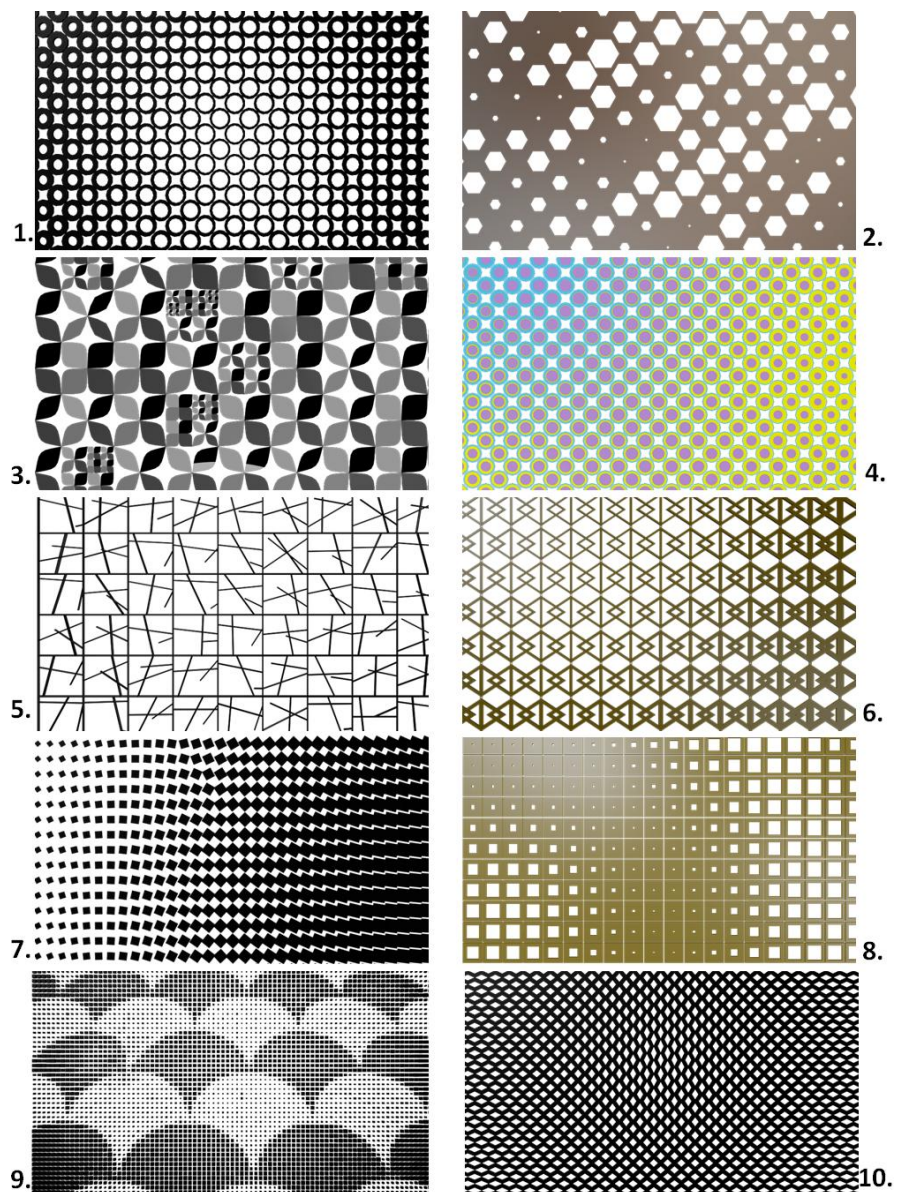

Fig.11.2 – A set of several different patterns developed using our framework

Equally important is the effort required to use our framework. Our empirical evaluation shows that the classification step requires between five and ten

minutes, while the selection, composition, and testing of the functions suggested by the classification takes between fifteen minutes and one hour, depending on the complexity of the facade. To prove our evaluation, we organized a table (Table.11.1) with the time spent in the generation of each example represented in Fig.11.2. The total time estimated for the generation of the models includes (1) the time needed for the classification, (2) the time spent in the algorithmic implementation and (3) the generation of the model, for which we used the AutoCAD software.

PATTERN	CLASSIFICATION TIME	ALGORITHMIC IMPLEMENTATION TIME	MODEL GENERATION TIME	TOTAL TIME
1.	2 min	8 min	1 min	11 min
2.	2 min	8 min	2 min	12 min
3.	4 min	10/15 min	3 min	17/22 min
4.	4 min	10/15 min	2 min	16/21 min
5.	3 min	20 min	2 min	25 min
6.	3 min	15 min	1,5 min	20 min
7.	3 min	5 min	0.5 min	9 min
8.	3 min	10 min	1 min	14 min
9.	4 min	10 min	40 min	54 min
10.	3 min	10 min	1 min	14 min

Table.11.1 – The generation time of each model present in Fig.10.2: the first column has the corresponding pattern's number; the second columns the time needed for the classification; the third columns the time spent in the algorithmic implementation; the forth columns has the model's generation time using the AutoCAD software; the fifth columns has the total generation time

The model which estimated time is out of the overall average, with a total of 54 minutes to be generated (model 9) is a special case, because it is composed by thousands of elements, where each element corresponds to one pixel of the image, which in this case has a resolution of 96x103 pixels, corresponding to 9 888 elements.

11.2 TRADITIONAL VS. ALGORITHMIC APPROACH

In order to compare the time spent in the generation of a facade's model using our framework and using a traditional approach, we selected two designs of facades as examples, to produce via both approaches. The goal is to estimate the time spent in the generation of the same model using both approaches and, in the end, conclude which of the two is most viable.

In order to make this analysis more precise, we selected two facades' models to perform the tests. The first example is a non-complex and regular design, while the second one is a slightly complex.

In a first stage, both designs are generated using an algorithmic approach (which corresponds to our framework) and using a traditional approach, i.e. the models are manually produced using the AutoCAD software.

In a second stage, after both models are totally generated, we produce some posthumous changes/variations to one of the generated models using both approaches, traditional and algorithmic, to compare the differences between them when it comes to the design change.

11.2.1 THE MODELS GENERATION TIME

The first example is a model of a straight facade composed by circular elements with fixed sizes and distributed linearly. The model's dimensions are 8x6m and the number of elements is 16x12 elements (Fig.11.3). The generation of this model took around twenty minutes using the algorithmic approach, while using the traditional approach it took around ten minutes.

In this case, the traditional approach took less time to generate the same model than the algorithmic approach. We can conclude that in a case of a simple model with a regular design, i.e. without variations and complex shapes, the traditional approach can be more viable.

Nevertheless, if this model had more elements or bigger size dimensions, the model would take proportionally more time to be generated using the traditional approach: if the model had 160x120 elements, instead of 16x12, it

would take more time, i.e. more than 20 minutes. As the algorithmic approach takes almost the same time to generate a model with 10 or 1000 elements, both approaches would take almost the same time to generate the same model.

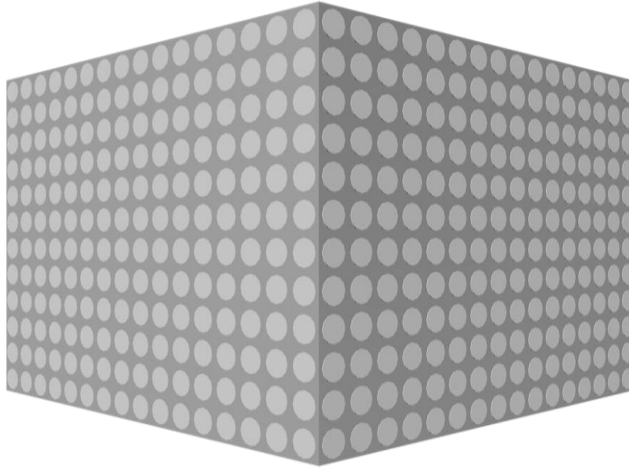

Fig.11.3 – MODEL 1: straight surface, circular elements, fixed sizes, regular distribution.

The second model has a straight facade composed by circular elements distributed alternately (which corresponds to the alternated-grid distribution), which have an increasing size variation along the facade's length (see Fig.11.4). As the previous example, we took almost the same time to generate this model using the algorithmic approach, i.e. approximately twenty minutes. On the other hand, we spent almost forty minutes to generate this model using the traditional approach.

After comparing the time spent in each approach we can conclude that, if we want to generate a regular and non-complex facade, the traditional approach may be more viable than the algorithmic approach, as it is a more repetitive process without almost no variations. Otherwise, when the facades are a bit more complex, the algorithmic approach proved to be more viable and, the more complex the design is, the greater the advantage is of using an algorithmic approach. In fact, when the design complexity is high, it is almost impractical to manually produce the models.

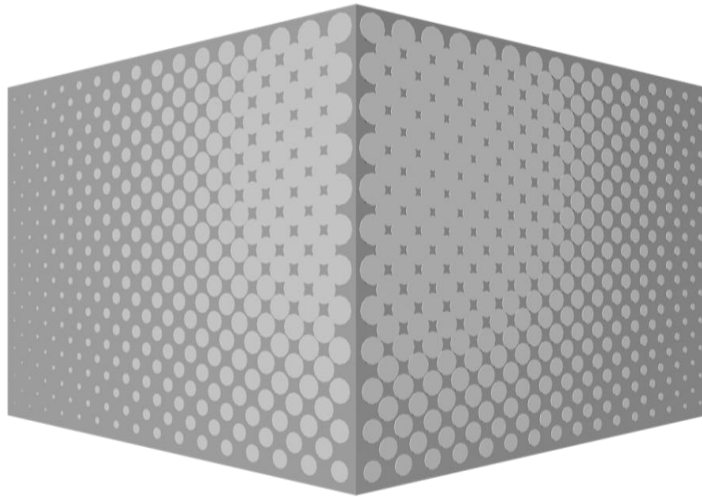

Fig.11.4- MODEL2: straight geometry, circular elements, increasing size, alternated-grid distribution.

11.2.2 THE VARIATION OF THE MODELS

The second stage of our analysis compares the ease of making changes in the generated models using both approaches. For this, we selected the first model developed in the previous sub-section (the model in Fig.11.3), on which we then apply some variations.

The first change was varying the size of the elements linearly along the facade's length and height, i.e. similar to the model in Fig.11.4, but the size of the elements also varies vertically (see Fig.11.5). When we use a traditional approach, this change forces us to modify all the elements one by one:

- 1.** either we erase all the elements and, then, we reproduce them again with a different size;
- 2.** or we scale the elements one by one.

This change takes almost the same time and effort as the initial generation of the whole model. On the other hand, when we use the algorithmic approach, we can easily control and produce this same change to the model, in a short period of time.

In fact, we changed the model in approximately two or three minutes using the algorithmic approach, while using the traditional approach, we took around thirty minutes to change the model. After comparing both approaches, we conclude that the algorithmic approach is much more viable than the traditional approach, when it comes to change models.

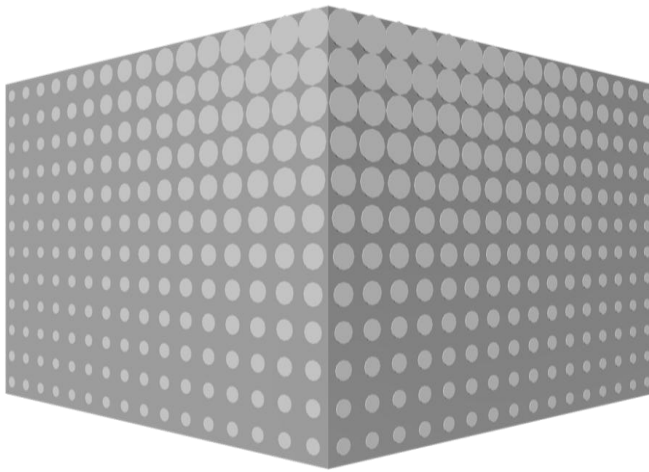

Fig.11.5 – CHANGING MODEL1: changing the type of size variation of the circles to become attracted to one point.

This situation gets worse for the traditional approach when the design's changes cover a larger scale of variations, affecting several parts of the model. We can prove this through the application of the following set of changes on the model: we change the elements' type of size variation to Random-size and the elements' geometry to Squared-geometry (Fig.11.6).

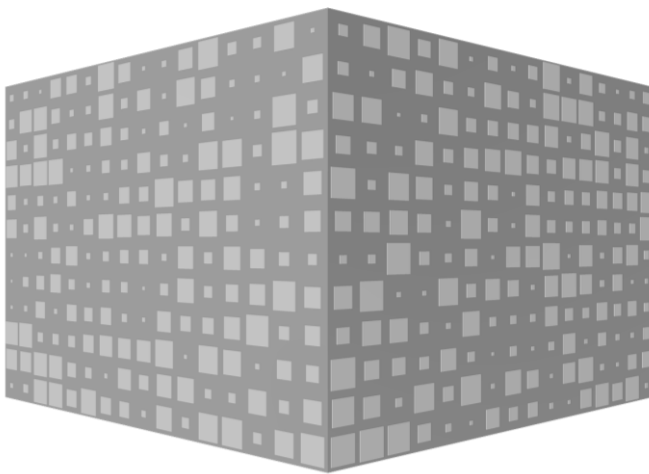

Fig.11.6 – CHANGING MODEL1: changing the elements' geometry and the type of size variation.

Using the traditional approach these variations took around forty-five minutes to be produced. Again, these changes forced us to eliminate all the previous elements (circles) to then generate the new elements (squares) one by one. Moreover, we had to generate each element with a different value chosen randomly.

Conversely, when we used the algorithmic approach, these variations took approximately eight minutes, since they were produced simply by changing the name of some of the functions used. When comparing both approaches,

we conclude that the algorithmic approach took less than one-quarter of the time of the tradition approach.

COMPARING BOTH APPROACHES	TRADITIONAL APPROACH	ALGORITHMIC APPROACH
MODEL 1	10 MINUTES	15-20 MINUTES
MODEL 2	40-45 MINUTES	15-20 MINUTES
CHANGE 1 MODEL 1	25-30 MINUTES	2-3 MINUTES
CHANGE 2 MODEL 1	45-50 MINUTES	6-8 MINUTES

Table.11.2 – The models generation time using both traditional and algorithmic approaches.

After analyzing the information represented in the table above (Table.11.2), we can conclude that:

- (1) To generate simple models the algorithmic approach may not be justifiable;
- (2) To generate models with a bit or a lot of complexity, the algorithmic approach is the most suitable and viable option.
- (3) To change the models, the most viable and flexible approach is the algorithmic approach, even when the original model was simple and with almost no complexity.

To sum up, when using the algorithmic approach, changing one variable of the model takes approximately 1/10 of the time taken by the traditional approach. Now, imagine we want to apply four changes to the MODEL1: a different facade's geometry, different type of elements distribution, different type of size variation and a different elements' rotation. Based on the Table.11.2 values, we can estimate that these changes would take almost two hours using the traditional approach and a maximum of twenty minutes using our framework.

To make this analysis, we used models with low complexity due to the circumstances and yet the algorithmic approach proved to be the most

advantageous. In case of more complex models, the difference between the times of both approaches would be even higher.

11.3 THE PORTABILITY OF THE FRAMEWORK

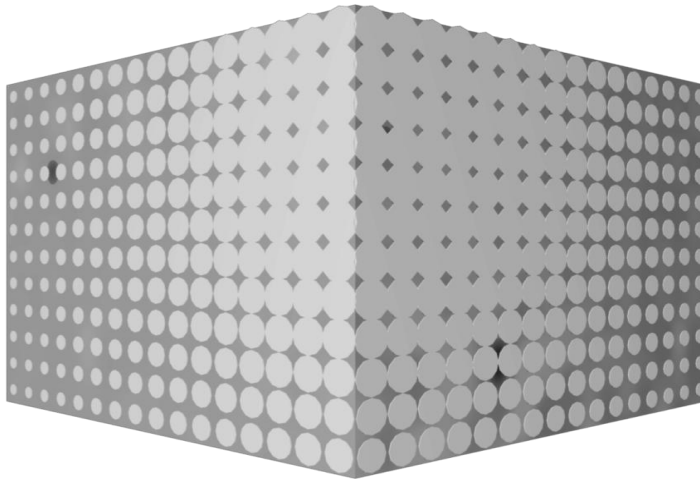

Fig.11.7 – MODEL 3: in this section this model is used to prove the portability of our framework.

The current implementation of the framework was done using the Rosetta IDE (Lopes & Leitão, 2011). This has the significant advantage of making the framework portable across the different CAD tools supported by Rosetta. Portability is the ability of a program to be compiled or run in a different environment and, in our case, it allows us to produce identical models in different CAD tools, such as Rhino, AutoCAD, SketchUp and Revit. In fact, the use of this framework is not restricted to a single CAD tool, as it happens with other similar frameworks, thus liberating the designer from the limitations of any specific CAD software. Moreover, it allows the designer to easily change the CAD tool that he wants to use.

Additionally, Rosetta also promotes portability across the supported programming languages, allowing the exploration of the framework in different programming languages such as Autolisp, Python, Processing and Javascript. As a result, in order to use our framework, designers can choose the programming language that they are more familiarized with, without forcing them to learn a new language.

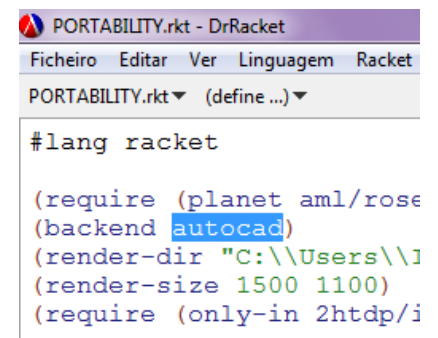

Fig.11. 8 – A print screen of the environment of DrRacket, with the corresponding backend. We simply have to write the name of the software that we want to use to change the environment backend.

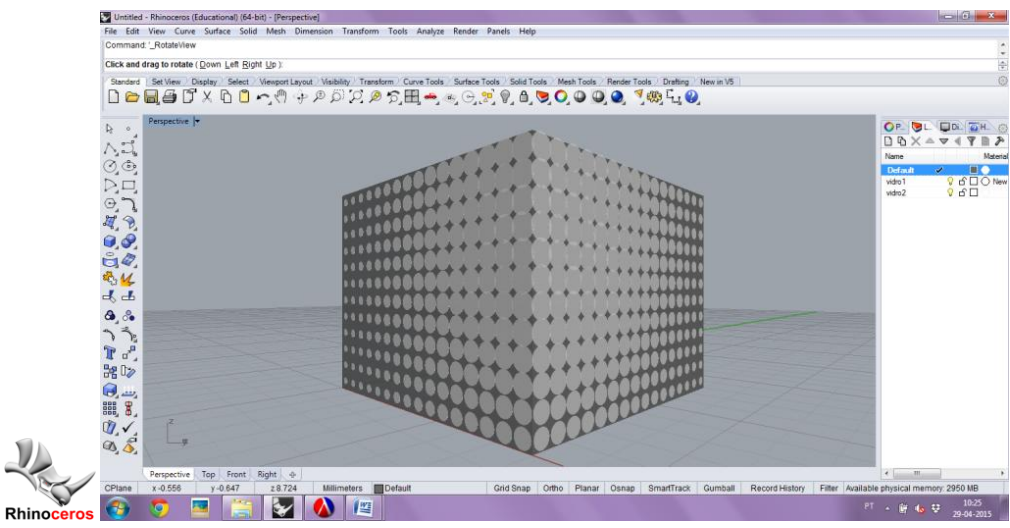
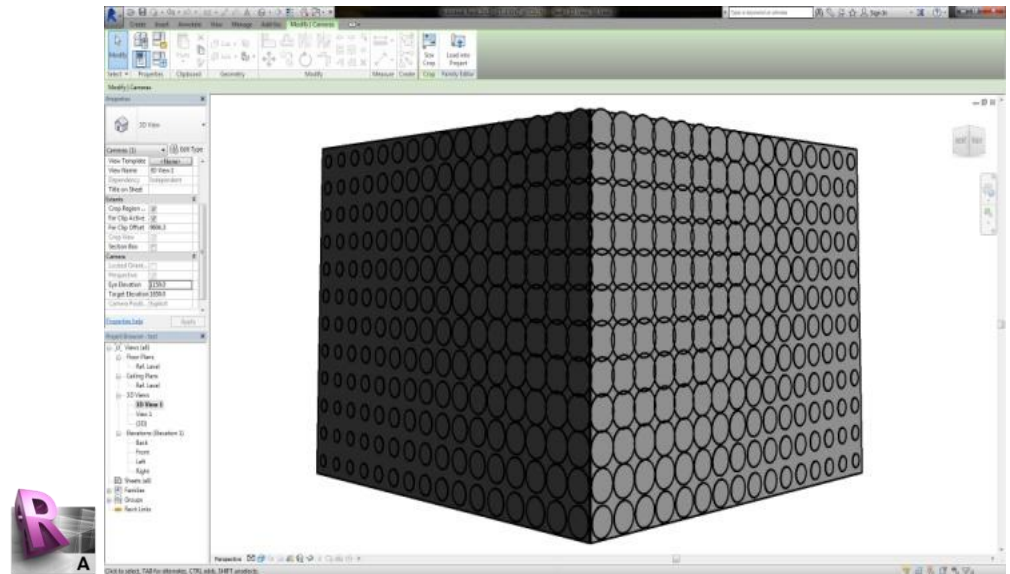
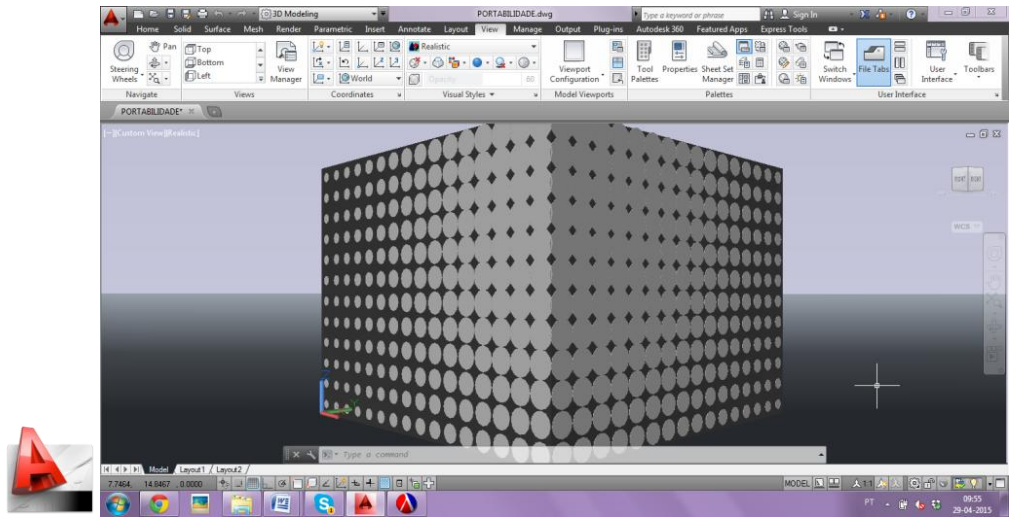

Fig.11.9 – Print Screens of three different environments with the same model: AutoCAD, REVIT and Rhino5.

11.4 OTHER EXISTING TOOLS

There are already some tools that attempt to solve the problems here described, such as the Paneling Tools plug-in for Rhino and Grasshopper, the Lunch Box add-on to Grasshopper, and ParaCloud Gem, a stand-alone toolkit that adds generative capabilities to any CAD system that supports *.obj, *.stl, *.collada, and *.dxf file formats. All of them are capable of creating grids of points on a surface, mapping elements in different ways, applying attractors to control elements size, etc.

The nature of their limitations is three-folded: (1) its use is entirely manual, thus mainly promoting iterative user-driven processes, which can be tiresome and error-prone; (2) when using such toolkits in the context of an Application Programming Interface (API) or as plug-ins to a domain-specific programming language, such as Grasshopper, a certain level of automation is obtained, however, the designer is always bound to the specific functionalities provided by the tool, thus limiting its agency in exploring different combinations of operations and extending the capabilities of the tool's pre-defined operations; (3) these tools are more used for generic panelization, subdivision, and population of surfaces thus, although they have been used to generate complex facade patterns, they are not fully architectural oriented which means that they do not directly address relevant concepts in facade design such as materiality or the tectonic relation between the facade elements

We should also mention recent domain-specific programming languages, such as Dynamo for Revit and Grasshopper for Rhino, which allow users to implement the functionalities proposed in this paper. In addition, some of the pre-defined components have similar purpose to some of the HOFs which we presented. However, the freedom of connection allowed by these tools becomes difficult to manage in complex facades (Leitão, et al., 2012). In these cases, a more structured and systematic approach like the one we propose is more manageable.

In summary, with the current framework the architect is limited by the non-domain specificity of existing tools or in order to extend their capabilities he

needs to build from scratch the necessary functionalities or use a mix of different tools that most of the time are not compatible. This work extends the state-of-the-art by: (1) systematizing and structuring, in an architectural-oriented framework, the parametric generation of a wide range of facade typologies, and by (2) operationalizing it resorting to a simple algorithmic approach that uses and combines different functional operators that directly implement facade design concepts.

12 CONCLUSION AND FUTURE WORK

12.1 CONCLUSION

The current exploration of architectural facades is not new. However, by resorting to recent digital technologies, architects can once again focus on facade design, promoting a growing interest in the exploration of complex patterns and geometries. Architectural practice has been increasingly focusing on the expression of buildings skins, which are characterized by complex geometries, textures and patterns. The majority of these highly textured facades are produced via a generative approach, however, as only a small percentage of the architectural studios is already using generative design, we found this topic of simplifying the generation of facades very interesting.

This dissertation presents a methodological framework that helps designers in the generation of different facade designs and geometries. We propose an algorithmic approach to design that overcomes the limitations of a traditional approach: The framework is composed by a set of functional operators and the current implementation was done using the Rosetta IDE (Lopes & Leitão, 2011), allowing its exploration in different programming languages and different CAD tools.

In order to systematize and simplify the use of the framework, we propose a classification of facades based on several categorical dimensions which we consider to be computationally relevant. These categorical dimensions guide us in the selection of the functional algorithms that handle each part of the facade. These might then be used directly, or might be combined using functional operators, promoting a systematic exploration of designs which ultimately aims to a higher productivity by: (1) improving the time of scripting tasks, and (2) adding flexibility to the designers' workflow. Due to the simplicity of the functional composition, this framework accommodates

the ever-changing nature of a design process by facilitating the test of several design concepts, or instantiations of the same idea, in any design stage.

To evaluate the framework, we produced several models of facades with different designs and several possible variations. These simulations allowed us to prove the applicability of our framework in the early stages of the facade' design, as also in the exploration of the model's flexibility.

With this evaluation we proved that our framework:

(1) is sufficiently **flexible**: it accommodates changes previously anticipated and changes that were not planned, which are our major focus, because architectural practice is characterized by changes frequently without being anticipated;

(2) supports **complex designs**: the creation and experimentation of new designs using the operators provided by our framework can achieve both idealized and unthought designs. The framework also achieves a high level of design fidelity;

(3) increases the **range of designs** that can be generated and experimented: when the designs are complex (like the examples developed in this thesis), it is impractical to use a traditional approach to generate them because the work becomes too difficult and the time spent is too large.

(4) is **portable**: it enables the generation of the same design/model in different backend, such as AutoCAD, Rhino and REVIT. This promotes even more possibilities for the end purpose of our framework.

Our proposal does not exclude other approaches for the design process, it simply is an additional stage specialized in the generation of buildings skins. Instead, it allows the designer to go farther in the exploration of different design solutions to apply on architectural facades, such as complex geometries, intricate patterns and new textures.

In the near future, we plan to expand the set of functional algorithms and operators, covering a wider range of facades. In order to make this framework more usable, we are particularly interested in conducting a larger

field study of its application, to identify weaknesses of the proposed processes and opportunities for extensions.

12.2 FUTURE WORK

Future work should improve the evaluation and development of the algorithmic framework for the generation of facades. Below, we present some topics that might help achieving that goal.

1. Extend the framework and the corresponding facade's classification

1.1. We developed a classification for facades and also a set of operators for the generation of facades' designs. The main aim was to facilitate and accelerate the generation and exploration of facades' models. For this, we created the classification, which was inspired on the most commons designs and patterns found in contemporary facades. The framework also enables the implementation of operators for more specific designs, which are not found in our framework's space. It will be interesting to pre-define more operators that will achieve more specific designs and geometries, thereby increasing the framework's space and the corresponding classification (including more categorical dimensions or options within each of the existing dimensions).

1.2. The framework's operators were predefined in terms of parametric functions, however, it will also be interesting to have functionality within our framework that takes hand-crafted surfaces and, then, translates them into parametric functions controllable by the designers.

1.3. It will be interesting to organize the framework into a more visually attractive and friendly application environment, which allowed its use by designers who are not familiarized with programming languages.

2. Connecting the framework with manufacturing

2.1. The framework was developed to help and facilitate the generation process of facades models. Thus, in order to further complement the framework's application, it will be useful to develop an extension for the framework that suggests solutions to (1) the structure and (2) the application

of the generated models to constitute real facades. This includes the methods whereby the facades should be applied and fixed, when passing the stage of the 3D model to the stage of construction.

2.2. We developed this framework with focus on the design process. However, after the exploration and definition of a facade's design, there are always some external factors which influence the design's final selection, such as economic factors. It will be interesting to add an extension to the framework that would be in charge of calculating the estimated cost for the generated model. This estimate should consider (1) the quantities of the selected materials, (2) the type of fabrication required to produce each facade and (3) the approximate time required for its construction.

2.3. Complex designs and geometries sometimes seem to have a rather difficult fabrication and designers have to look for fabrication processes that suit their design solutions. Another important feature for the extension of this framework will suggest the type of fabrication process that best suits each facade according to its type of design and selected materials.

Briefly, future work can follow three different routes, extending the classification and the corresponding functional operators, developing new features to help the passage of the models to the manufacturing phase, or both.

12.3. CONTRIBUTIONS

This dissertation proves the relevance of generative Design, in particular, the algorithmic approach, as an auxiliary tool that supports both exploration of designs and decision-making activities in architectural practice.

In this dissertation we discussed the development of a computational framework based on an algorithmic approach for the design of facades and we presented two important contributions.

The first contribution is a classification of facades into different categorical dimensions that we consider computationally relevant, which was based on an analysis of a large corpus of contemporary facades.

The second one is the identification and implementation of a set of algorithms and strategies that address the needs of the different dimensions, generating then different designs of facades.

As the framework uses an algorithmic approach, it is also useful to allow the exploration of different design solutions with almost no effort and time, only by combining the functional operators provided by the classification.

BIBLIOGRAPHY

Albayrak, C., (2011) *Performative Architecture as a Guideline for Transformation of the Defence Line of Amsterdam*, s.l.: Delft University of Technology.

Alfaris, A., (2009) *Emergence through conflict: the Multi-Disciplinary Design System (MDDS)*, s.l.: Massachusetts Institute of Technology.

Anderson, J. & Tang, M. (2011) *Form Follows Parameters: Parametric modeling for fabrication and manufacturing processes*. s.l., CAADRIA.

Arch2o. [Online] Available at: <http://www.arch2o.com/re-appreciating-infrastructure-the-may-september-art-facade-urbana-architects/> [Accessed em 28 Agosto 2014].

ARC239 Parametricism. [Online] Available at: www.arc239parametricism.wordpress.com/author/taf123/ [Accessed in October 2014]

Barrios, C., (2005) *Transformations on Parametric Design Models: A Case Study on the Sagrada Familia Columns*. s.l., Springer- CAAD Futures.

Beeby, T. H., (1977) The Grammar of Ornament/ Ornament As Grammar. *VIA III Ornament*, pp. 11-29.

Bentley, P.(2010) *London's Global University*. [Online] Available at: <http://www0.cs.ucl.ac.uk/staff/p.bentley/teaching> [Accessed on 07 December 2010].

Bordeleau, A., (2009) Charles Robert Cockerell's architecture and the language of ornaments. *The Journal of Architecture*, Volume 14, pp. 465-490.

Borson, B., (2010) *Life of an Architect*. [Online] Available at: <http://www.lifeofanarchitect.com/words-that-architects-use/>

Bukhari, F. A., (2011) *A Hierarchical Evolutionary Algorithmic Design (HEAD) System for Generating and Evolving Buildings Design Models*, s.l.: Queensland University of Technology.

Burry, M., (1999) Paramorph. In: *Hypersurfaces 2*. s.l.:Academy Editions , pp. 78-83.

Burry, M., (2003) Between intuition and process: Parametric design and rapid prototyping.. In: B. Kolarevic, ed. *Architecture in the digital age - design and manufacturing..* s.l.:s.n.

Burry, M. & Murray, (1997) *Computer aided architectural design using parametric variation and associative geometry*. Vienna, Austria , ECAADE conference Proceedings.

Chouchoulas, O. & Day, A., (2007) Design exploration using a shape grammar with a genetic algorithm. *Open house International Vol 32*, 2007 jun.

Crawford, S., (2009) *An Architecture of Relationships Built on the Use of Parametric Modeling and Evaluative Analysis in Design*, USA: University of Washington.

Davis, D., (2013) *Modelled on Software Engineering: Flexible Parametric Models in the Practice of Architecture*. s.l.:RMIT University.

Designing Buildings. [Online] Available at: http://www.designingbuildings.co.uk/wiki/Beijing_National_Stadium [Accessed in April 2015].

Dezeen Magazine. [Online] Available at: <http://www.dezeen.com/2014/08/29/campus-netzwerk-office-format-elf-architekten-perforated-aluminium/> [Accessed on 29 August 2014].

Eastman, C., Teicholz, P., Sacks, R. & Liston, K., (2008) *BIM Handbook: A guide to Building Information Modeling for Owners, Managers, Designers, Engineers, and Contractors*. 1^o ed. New Jersey: John Wiley & Sons, Inc..

Edler, J.,(2005) Communicative Display Skin for Buildings: BIX at the Kunsthau Graz. In: B. K. & A. M. Malkawi, ed. *Performative Architecture Beyond Instrumentality*. New York: Spon Press, pp. 150 - 160.

Fasoulaki, E., 2007. *Genetic Algorithms in Architecture: a Necessity or a Trend?*. [Online] Available at: <http://www.generativeart.com/on/cic/papersGA2007/09.pdf>.

Fasoulaki, E., (2008) *Integrated Design: A Generative Multi-Performative Design Approach*, s.l.: Massachusetts Institute of Technology.

Fernandes, R., (2013) *Generative Design: a New Stage in the Design Process*, Lisboa: Instituto Superior Técnico.

Fouad, S., (2012) *Design Methodology: Kinetic Architecture*, s.l.: Alexandria University.

Frampton, K. (1983) Towards a Critical Regionalism: Six Points for an Architecture of Resistance. *The Anti-Aesthetic: Essays on Postmodern Culture*.

Frasconi, M. (1983) The Tell-the-tale Detail. In: J. Deely & M. Lenhart, eds. *Semiotics*. s.l.:Springer US, pp. 325-336.

Gavra, H. (2013) *Contemporary Ornament: from the Object Towards a quasi-object*. s.l., IDEA@UdeM 2013.

Gramazio, F. & Kohler, M. (2008) Chapter9. Towards a Digital Materiality . In: B. Kolarevic & K. Klinger, eds. *Manufacturing Material Effects: rethinking Design and Making in Architecture*. New York: Routledge, pp. 101 - 118.

Hagan, S., (2008) *Digitalia - Architecture and the Digital, The environmental and the Avant-Garde*. s.l.:s.n.

Hauer, E., (2004) *Erwin Hauer: Continua, Architectural Screens and Walls*. s.l.:Princeton Architectural Press.

Heikkinen, M. & Kareoja, P., (2011) *The Aalto Ornament Studio - Theory as a Design Tool*. Helsinki, Finland: Aalto University School of Engineering.

Heylighen, A. & Martin, G., (2004) *That Elusive Concept of Concept in Architecture*. Netherlands, Design Computing and Cognition.

Hudson, R., (2010) *Strategies for Parametric Design in Architecture: An application of practice led research.*, s.l.: University of Bath, Department of Architecture and Civil Engineering.

Hudson, R., Shepherd, P. & Hines, D. (2011) Aviva Stadium: A case study in integrated parametric design. *International Journal of Architectural computing*, Volume 09, pp. 187- 204.

Jabi, W., (2013) *Parametric Design for Architecture*. London: Laurence King Publishing.

Klinger, K. R.(2008) Chapter2. Relations: Information Exchange in Designing and Making Architecture. In: B. Kolarevic & K. Klinger, edits. *Manufacturing Material Effects: Rethinking Design and Making in Architecture*. New York: Routledge, pp. 25 -36.

Knight, T., (1999) *Applications in Architectural design, and Education and Practice*, s.l.: NSF/MIT.

Kolarevic, B., (2003) *Architecture in the Digital Age - Designing and Manufacturing*. London, UK, Spon Press.

Kolarevic, B., (2005) 15. Towards the Performative in Architecture. In: *Performative Architecture . Beyond Instrumentality*. s.l.:Spon Press.

Kolarevic, B. & Klinger, K. R., (2008) 1. Manufacturing/ Materials/ Effects. In: B. Kolarevic & K. R. Klinger, edits. *Manufacturing Materials Effects: Rethinking Design and Making in Architecture*. New York: Routledge, pp. 5 - 24.

Krish, S., (2013) *Generative Design*. [Online] Available at: www.generativedesign.wordpress.com

Leitão, A., (2013) *Teaching Computer Science for Architecture*. s.l., Future Traditions - 1st ECAADE Regional International Workshop.

Leitão, A., (2014) *Improving Generative Design by Combining Abstract Geometry and Higher-Order Programming*. Kyoto, Japan, CAADRIA.

Leitão, A., Santos, L. & Lopes, J. (2012) Programming languages for generative design: A comparative study. *International Journal of Architectural Computing*, 10(1), pp. 139-162.

Loos, A., (1908) *Ornament and Crime*, Vienna: s.n.

Lopes, J. & Leitão, A., (2011) *Portable Generative Design for CAD Applications*. Calgary, Canada, s.n.

Lovell, S., (2008) Re-Sampling Ornament. *Blueprint*, September, p. 34.

- Lynn, G.**, (2004) *The Structure of Ornament*. s.l.:s.n.
- McNicholas, M. T.**, (2006) *The Relevance and Transcendence of Ornament: A new Public*, s.l.: University of Notre Dame.
- Meagher, M., Maas, D. V. D., Abegg, C. & Huang, J.**, (2009) *Dynamic Ornament: Climatically responsive surfaces in architectural design*. s.l., CAAD Futures.
- Miller, K.**, (2011) *Organized Crime: The Role of Ornament n Contemporary Architecture*. s.l., ACADIA Regional.
- Mitchell, M.**, (1996) *An Introduction to Genetic Algorithms*. Cambridge: MIT Press.
- Moneo, R.**, (2001) The Thing Called Architecture. *Anyone Corporation New York*, pp. 120 - 123.
- Moussavi, F. & Kubo, M.**, (2006) *The function of Ornament*. s.l.:Actar.
- Oxman, R.**, (2006) Theory and design in the first digital age. In: *Design Studies Vol. 27*. s.l.:s.n., pp. 229-265.
- Pell, B.**, (2010) *The Articulate Surface - Ornament and technology in Contemporary Architecture*. s.l.:Birkhauser.
- Peters, B.**, (2007) *The Smithsonian Courtyard Enclosure*. Nova Scotia, CANADA, s.n.
- Phillips, T.**, (2003) Ornament on Trial. *The Architectural Review*, April, pp. 79-87.
- Rohe, M.**, (1953) A Speech to IIT (1950). In: P. Johnson, ed. *Mies van der Rohe*. s.l.:New York: Museum of Modern Art.
- Rozenberg & Salomaa**, (1980) *The Mathematical Theory of L Systems*. New York: Academic Press.
- Santos, L., Lopes, J. & Leitão, A.**, (2012) *Collaborative Digital Design: When the architect meets the software engineer*. Prague, Czech Republic, Digital Physicality - Proceedings of the 30th eCAADe Conference.
- Schimek, H., Stavric, M. & Wiltsche, A.**, (2008) *The Inteligence of Ornaments: Exploring ornamental ways of Affordable Non-Standard Building Envelops*. s.l., CAADRIA.
- Schnädelbach, H.**, (2010) *Adaptive Architecture - A Conceptual Framework*, s.l.: University of Nottingham.
- Schumacher, P.**, (2008) *Parametricism as Style - Parametricist Manifesto*. s.l., s.n.
- Semper, G.**,(2004) *Style in the Technical and Tectonic Arts (originally published in 1860-1863)*. Los Angeles: Getty Research Institute.
- Shepherd, P., Hudson, R. & Hines, D.**, (2011) Aviva Stadium: A parametric success. *International Journal of Architectural Computing*, Volume 09, no. 2, pp. 167 - 186.

- Sherman, P.**, (1962) *Louis Sullivan: An Architect in American Thought*. s.l.:Prentice-Hall.
- Stocking, A.**, (2009) *Generative Design is Changing the Face of Architecture*. [Online] Available at: <http://www.cadalyst.com/cad/building-design/generative-design-is-changing-face-architecture-12948> [Accessed in December 2014].
- Strehlke, K. & Loveridge, R.**, (2005) *The redefinition of Ornament*. s.l., Netherlands, Springer - CAAD Futures.
- Sumi, K.**, (2013) *Parametric Design - A new Paradigm in Architecture*. [Online] Available at: https://www.academia.edu/2644485/parametric_design [Accessed in November 2014]
- Terzidis, K.**, (2003) Introduction. In: *Expressive Form - A conceptual approach to computational design*. s.l.:Spoon Press, pp. 1 - 8.
- Terzidis, K.**, (2006) *Algorithmic Architecture*. s.l.:Architectural Press.
- Venturi, R.**, (1966) *Complexity and Contradiction in Architecture*. s.l.:s.n.
- Watts, A.**,(2007) *Scratching the Surface: New London Facades by London Architects*. England: Springer Wien New York .
- Whalley, A.**, (2005) Chapter2. Product and Process: Performance-Based Architecture. In: B. Kolarevic & A. M. Malkawi, edits. *Performative Architecture - Beyond Instrumentality*. s.l.:Spoon Press, pp. 22-40.
- Whitehead, H.**, (2003) Laws of Form. In: B. Kolarevic, ed. *Architecture in the Digital Age: Design and Manufacturing* . New York: Spon Press, pp. 82-100.
- Woodbury, R.**, (2010) *Elements of Parametric Design*. s.l.: Routledge.
- Woodbury, R. et al.**, (2011) *Change detection in 3D parametric systems: Human Centered interfaces for change Visualization*. s.l., CAAD Futures.